

# i16S

## Safety switches

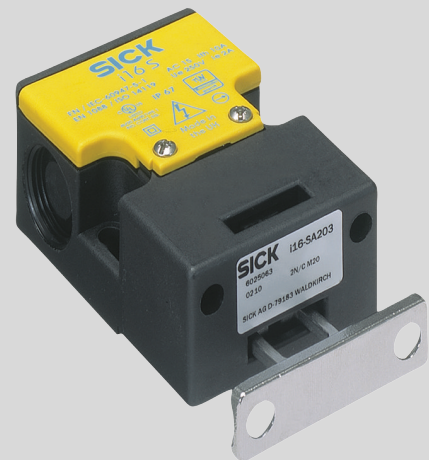

---

**Described product**

i16S

**Manufacturer**

SICK AG  
Erwin-Sick-Str. 1  
79183 Waldkirch  
Germany

**Legal information**

This work is protected by copyright. Any rights derived from the copyright shall be reserved for SICK AG. Reproduction of this document or parts of this document is only permissible within the limits of the legal determination of Copyright Law. Any modification, abridgment or translation of this document is prohibited without the express written permission of SICK AG.

The trademarks stated in this document are the property of their respective owner.

© SICK AG. All rights reserved.

**Original document**

This document is an original document of SICK AG.



## Contents

<b>1</b>	<b>Scope.....</b>	<b>4</b>
<b>2</b>	<b>On safety.....</b>	<b>5</b>
2.1	Qualified safety personnel.....	5
2.2	Applications of the safety switches.....	5
2.3	Correct use.....	6
2.4	General safety notes and protective measures.....	6
<b>3</b>	<b>Mounting.....</b>	<b>7</b>
3.1	Reversing the actuating direction.....	8
3.2	Protection against surroundings.....	9
<b>4</b>	<b>Electrical installation.....</b>	<b>10</b>
4.1	Variants with M20 cable entry.....	10
4.2	Variants with M12 plug connector.....	10
<b>5</b>	<b>Commissioning.....</b>	<b>11</b>
5.1	Tests before the initial commissioning.....	11
5.2	Periodic technical inspections.....	11
<b>6</b>	<b>Disposal.....</b>	<b>12</b>
<b>7</b>	<b>Technical specifications.....</b>	<b>13</b>
7.1	General system data.....	13
7.2	Dimensional drawings.....	14
7.3	Minimum door radius.....	16
<b>8</b>	<b>Conformities and certificates.....</b>	<b>17</b>
8.1	EU declaration of conformity.....	17
8.2	UK declaration of conformity.....	17

### 1 Scope

These operating instructions are applicable to the i16S safety switch.

These operating instructions are original operating instructions.

## 2 On safety

This chapter deals with your own safety and the safety of the equipment operators.

- ▶ Please read this chapter carefully before working with the i16S or with the machine protected by the i16S.

The national/international rules and regulations apply to the installation, commissioning, use and periodic technical inspections of the safety switches, in particular

- the Machinery Directive,
- the Low Voltage Directive,
- the Work Equipment Directive,
- the safety regulations as well as
- the work safety regulations/safety rules.

Manufacturers and operators of the machine on which the protective devices are used are responsible for obtaining and observing all applicable safety regulations and rules.

### 2.1 Qualified safety personnel

The i16S safety switch must be mounted, installed and commissioned only by qualified safety personnel. Qualified safety personnel are defined as persons who

- have undergone the appropriate technical training

and

- have been instructed by the responsible machine owner in the operation of the machine and the current valid safety guidelines

and

- who have access to these operating instructions.

### 2.2 Applications of the safety switches

Safety switches of the i16S series are electromagnetic switching devices.

They secure moving protective devices with a guard function so that

- the dangerous state of the machine can only be switched on when the guard is closed,
- a STOP command is triggered if the protective device is opened while the machine is operating.

For the control this means that

- activation commands that cause dangerous conditions, may only become active when the guard is in the protective position and the dangerous conditions have been terminated before the protective position is cancelled.

Prior to the use of safety switches, a risk assessment must be performed on the machine.



### **WARNING**

The user is responsible for the safe integration of the safety switch in a safe overall system. For this purpose the overall system must be validated, e.g. in accordance with EN ISO 13849-2.

If the simplified procedure in accordance with section 6.3 EN ISO 13849-1 is used for validation, the Performance Level (PL) may be reduced if several devices are connected one after the other.

To determine the necessary reliability (Performance Level PL, SIL) for the safety function the related standards should be used:

- EN ISO 13849, Safety of machinery – Safety-related parts of control systems
  - EN 62061, Safety of machinery – Functional safety of safety-related electrical, electronic and programmable electronic control systems
- 

### **2.3 Correct use**

The i16S safety switch must be used only as defined in section 2.2 “Applications of the safety switches”. The safety switch must be used only on the machine where it has been mounted, installed and initialized by qualified safety personnel in accordance with these operating instructions.

The product may be used in safety functions.

All warranty claims against SICK AG are forfeited in the case of any other use, or alterations being made to the safety switch, even as part of its mounting or installation.

Correct use includes the regular inspection of the protective device by qualified safety personnel in accordance with section 5.2.

### **2.4 General safety notes and protective measures**

Safety switches provide a protection function for persons. Incorrect installation or manipulation can result in serious injuries.

---



### **WARNING**

Safety switches are not allowed to be bypassed, turned away, removed or made ineffective in any other manner. Take measures to reduce bypassing options as necessary.

Observe EN ISO 14119 for using interlocking devices associated with physical guards.

---



### **WARNING**

The switching procedure may only be activated by actuators specifically designated for that purpose, which are connected to the protective device in such a manner that they cannot be detached.

Restrict access to replacement actuators, so they cannot be used for bypassing.

---

### 3 Mounting



#### WARNING

Mounting is only allowed to be performed by qualified safety personnel.

- ▶ Observe EN ISO 14119 for using interlocking devices associated with physical guards.

Fit the safety switches such that

- it is difficult for operators to access when the protective device is open,
- it is possible to inspect and replace the safety switches.



#### NOTICE

Safety switches and actuators must not be used as a mechanical stop.

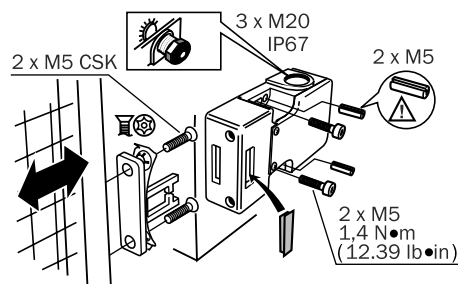

Figure 1: Mounting safety switch

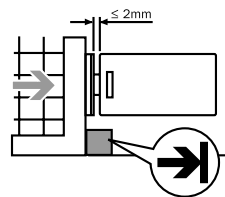

Figure 2: Mounting

- ▶ Mount the safety switch positively.
- ▶ Tighten the safety switch using 2 × M5 screws to 1.4 Nm (see figure 1).
- ▶ Connect the actuator to the protective device durably and non-detachably, e.g. using one-way bolts or by riveting or welding.
- ▶ Fit an additional stop for moving parts of the guard (see figure 2).
- ▶ Insert the actuator into the actuating head.

3.1 Reversing the actuating direction

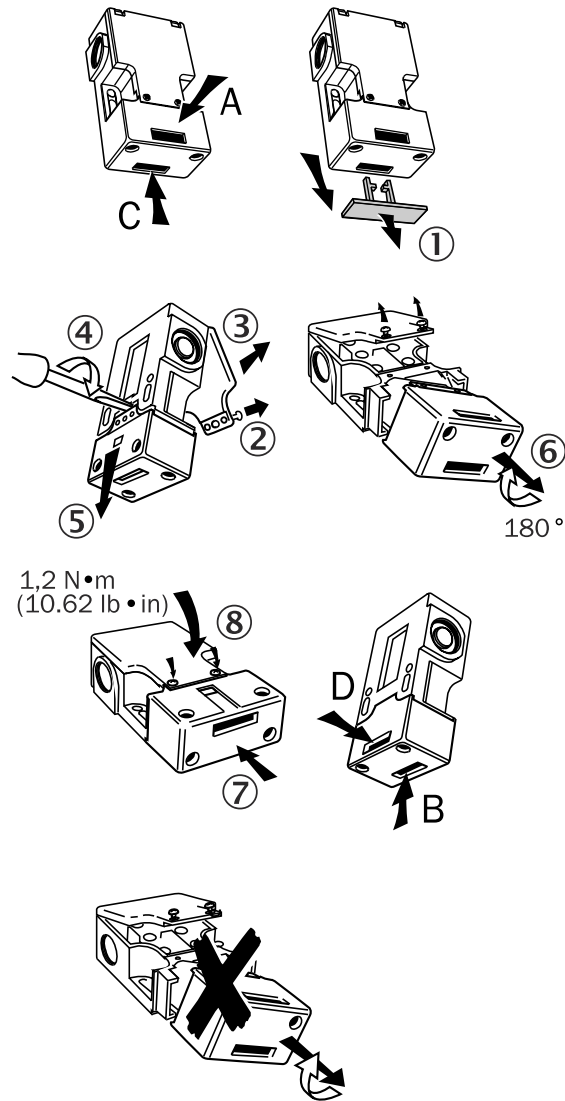

Figure 3: Reversing the actuating direction

- ▶ Insert the actuator.
- ▶ Undo the cover screws.
- ▶ Release catch on the actuating head.
- ▶ Rotate head by 180°.
- ▶ Engage.
- ▶ Tighten the cover screws.
- ▶ Seal unused actuating slots with the enclosed slot covers.



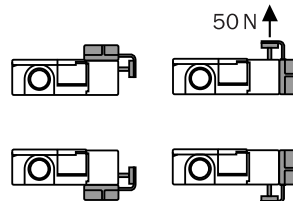
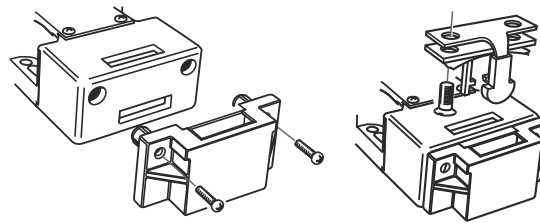

Figure 4: Mounting the catch and retainer kit iE16-SCR, only in conjunction with actuator iE16-S1

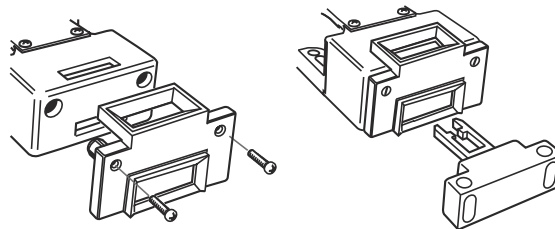

Figure 5: Mounting the alignment aid with actuator iE16-F1 or iE16-F2

### 3.2 Protection against surroundings

A precondition for a durable and perfect safety function is the protection of the actuating head against penetration by foreign matter such as shavings, sand, abrasive materials etc.

Cover the control slot, the actuator and the type label when painting.

## 4 Electrical installation



**WARNING**

The electrical connection is only allowed to be made by qualified safety personnel.

### 4.1 Variants with M20 cable entry

- ▶ Break open the desired opening.
- ▶ Fit the M20 cable gland with the corresponding enclosure rating.
- ▶ Contact assignments see figure 6, page 10.
- ▶ Operate all contact pairs in the same voltage range.
- ▶ Connect all live parts to one side of the contact block.

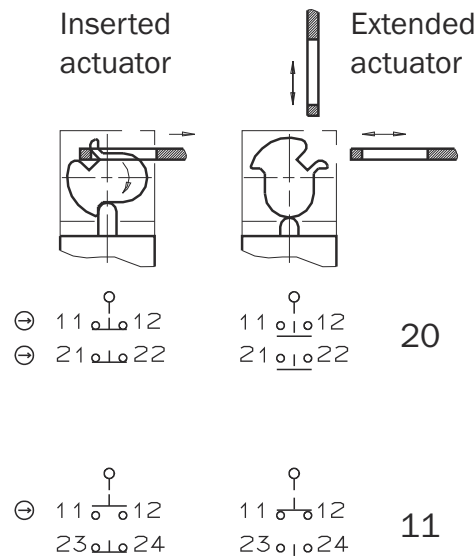

Figure 6: Switching elements and switching functions for variants with M20 cable entry

- ▶ Tighten the clamping bolts to 1.0 Nm.
- ▶ Ensure the cable entry is leak-proof.
- ▶ Close and screw switch cover in place.
- ▶ Tighten screw to 1.2 Nm.

### 4.2 Variants with M12 plug connector

	Pin	Assignment
	1/2	Positively guided NC contacts 11/12
	3/4	Positively guided NC contacts 21/22

## 5 Commissioning

### 5.1 Tests before the initial commissioning

- mechanical functional check It must be possible to insert the actuator into the actuating head without any problem. Close the protective device several times to verify.
- electrical functional check
- ▶ Close the guard.
- ▶ Start the machine.



#### **WARNING**

Check whether the machine stops when the guard is opened.

- ▶ Switch off the machine.
- ▶ Open the guard.
- ▶ Attempt to start the machine.



#### **WARNING**

The machine must not start with a guard open!

### 5.2 Periodic technical inspections

To ensure correct function over the long term, regular checks are necessary.

Daily or prior to the start of the shift the operator must check for:

- correct function
- no visible evidence of tampering

Regularly according to the machine maintenance schedule by qualified safety personnel:

- correct switching function



#### **DANGER**

Check whether the machine stops when the guard is opened.

- safe mounting of the modules
- deposits and wear and tear
- correct sealing of the cable entry or plug connection
- loose cable connections or plug connectors



#### **DANGER**

The entire switch and actuator must be replaced in the case of damage or wear and tear. It is not permitted to exchange individual components or modules!

Safety switches must be completely replaced after 1 million switching operations.

## 6 Disposal



Always dispose of serviceability devices in compliance with local/ national rules and regulations with respect to waste disposal.

## 7 Technical specifications

### 7.1 General system data

	i16-SA113 i16-SA203	i16-SA205
Housing material	Glass-reinforced polybutylene terephthalate	
Enclosure rating (IEC 60529)	IP67	
Mechanical life	1 × 10 <sup>6</sup> switching operations	
B1 <sub>10D</sub> (EN ISO 13849-1)	2 × 10 <sup>6</sup> switching operations with low load	
Type	Type 2 (EN ISO 14119)	
Actuator coding level	Low coding level (EN ISO 14119)	
Operating temperature	-20 ... +80 °C	
Type of connection	Cable entry 3 × M20	Plug connection 1 × M12 (4-pin)
Approach speed max.	10 m/min	
Retaining force max.	30 N	
Actuation frequency max.	7200/h	
Contact elements positively guided NC contacts/NO contacts	i16-SA113: 1/1 i16- SA203: 2/0	2/0
Rated impulse withstand voltage U <sub>imp</sub> contacts referred to housing	2500 V	1500 V
Rated insulation voltage U <sub>i</sub>	250 V	30 V
Usage category (IEC 60947-5-1)	AC-15: 240 V/3 A DC-13: 24 V/2 A	DC-13: 24 V/2 A
Switching voltage min.	5 V DC	
Switching current min. at 5 V DC	5 mA	
Connection cross-section	1 × 1,5 mm <sup>2</sup>	-
Short-circuit protection	T10/10 A	2 A
Torque requirements for screws		
Mounting screws housing	1,4 Nm	
Cover screws	1,2 Nm	
Jam screws contacts	1,0 Nm	
Minimum door radius	<a href="#">Minimum door radius</a>	

7.2 Dimensional drawings

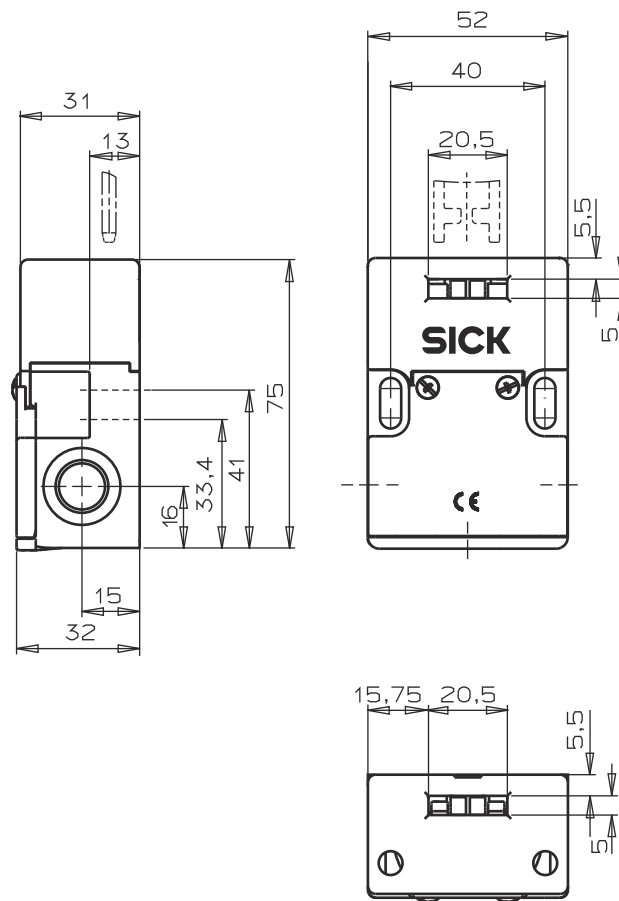

Figure 7: Dimensional drawing i16-SA113 and i16-SA203

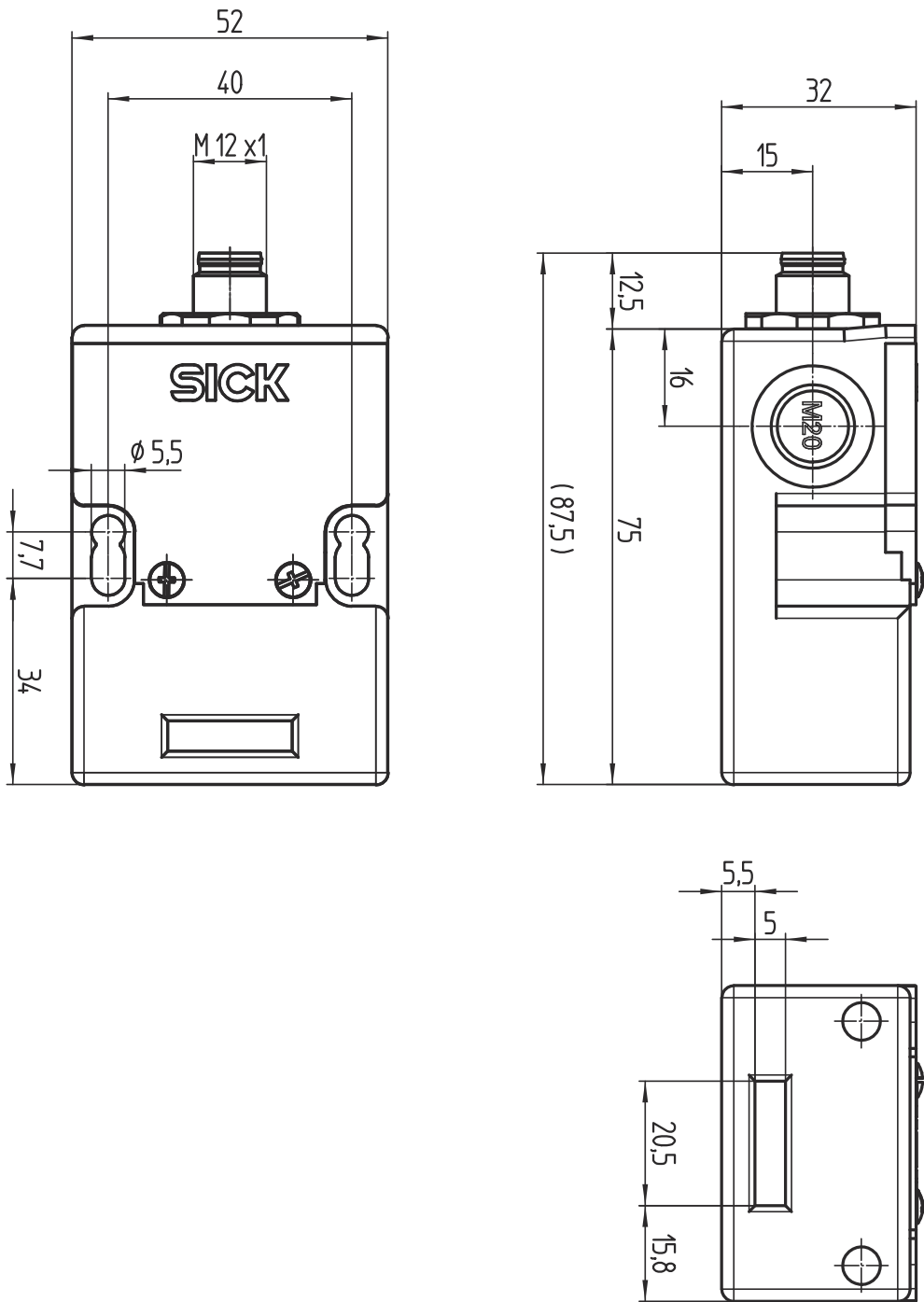

Figure 8: Dimensional drawing i16-SA205

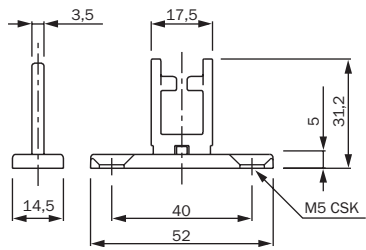

Figure 9: Dimensional drawing i16-SA205

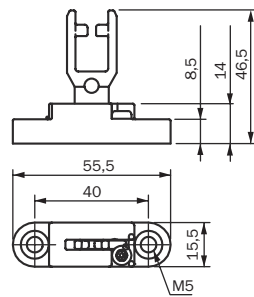

Figure 10: Dimensional drawing iE16-F2

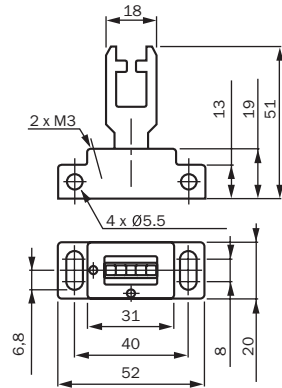

Figure 11: Dimensional drawing iE16-F1

### 7.3 Minimum door radius

<b>iE16-S1</b>	175 mm	175 mm	175 mm	175 mm
<b>iE16-F2</b>	175 mm	60 mm	60 mm	175 mm
<b>iE16-F1</b>	60 mm	60 mm	60 mm	60 mm



## 8 Conformities and certificates

You can obtain declarations of conformity, certificates, and the current operating instructions for the product at [www.sick.com](http://www.sick.com). To do so, enter the product part number in the search field (part number: see the entry in the “P/N” or “Ident. no.” field on the type label).

### 8.1 EU declaration of conformity

#### Excerpt

The undersigned, representing the manufacturer, herewith declares that the product is in conformity with the provisions of the following EU directive(s) (including all applicable amendments), and that the standards and/or technical specifications stated in the EU declaration of conformity have been used as a basis for this.

- ROHS DIRECTIVE 2011/65/EU
- MACHINERY DIRECTIVE 2006/42/EC

### 8.2 UK declaration of conformity

#### Excerpt

The undersigned, representing the following manufacturer herewith declares that this declaration of conformity is issued under the sole responsibility of the manufacturer. The product of this declaration is in conformity with the provisions of the following relevant UK Statutory Instruments (including all applicable amendments), and the respective standards and/or technical specifications have been used as a basis.

- Restriction of the Use of Certain Hazardous Substances in Electrical and Electronic Equipment Regulations 2012
- Supply of Machinery (Safety) Regulations 2008





**Australia**

Phone +61 (3) 9457 0600  
1800 33 48 02 – tollfree  
E-Mail sales@sick.com.au

**Austria**

Phone +43 (0) 2236 62288-0  
E-Mail office@sick.at

**Belgium/Luxembourg**

Phone +32 (0) 2 466 55 66  
E-Mail info@sick.be

**Brazil**

Phone +55 11 3215-4900  
E-Mail comercial@sick.com.br

**Canada**

Phone +1 905.771.1444  
E-Mail cs.canada@sick.com

**Czech Republic**

Phone +420 234 719 500  
E-Mail sick@sick.cz

**Chile**

Phone +56 (2) 2274 7430  
E-Mail chile@sick.com

**China**

Phone +86 20 2882 3600  
E-Mail info.china@sick.net.cn

**Denmark**

Phone +45 45 82 64 00  
E-Mail sick@sick.dk

**Finland**

Phone +358-9-25 15 800  
E-Mail sick@sick.fi

**France**

Phone +33 1 64 62 35 00  
E-Mail info@sick.fr

**Germany**

Phone +49 (0) 2 11 53 010  
E-Mail info@sick.de

**Greece**

Phone +30 210 6825100  
E-Mail office@sick.com.gr

**Hong Kong**

Phone +852 2153 6300  
E-Mail ghk@sick.com.hk

**Hungary**

Phone +36 1 371 2680  
E-Mail ertekesites@sick.hu

**India**

Phone +91-22-6119 8900  
E-Mail info@sick-india.com

**Israel**

Phone +972 97110 11  
E-Mail info@sick-sensors.com

**Italy**

Phone +39 02 27 43 41  
E-Mail info@sick.it

**Japan**

Phone +81 3 5309 2112  
E-Mail support@sick.jp

**Malaysia**

Phone +603-8080 7425  
E-Mail enquiry.my@sick.com

**Mexico**

Phone +52 (472) 748 9451  
E-Mail mexico@sick.com

**Netherlands**

Phone +31 (0) 30 229 25 44  
E-Mail info@sick.nl

**New Zealand**

Phone +64 9 415 0459  
0800 222 278 – tollfree  
E-Mail sales@sick.co.nz

**Norway**

Phone +47 67 81 50 00  
E-Mail sick@sick.no

**Poland**

Phone +48 22 539 41 00  
E-Mail info@sick.pl

**Romania**

Phone +40 356-17 11 20  
E-Mail office@sick.ro

**Russia**

Phone +7 495 283 09 90  
E-Mail info@sick.ru

**Singapore**

Phone +65 6744 3732  
E-Mail sales.gsg@sick.com

**Slovakia**

Phone +421 482 901 201  
E-Mail mail@sick-sk.sk

**Slovenia**

Phone +386 591 78849  
E-Mail office@sick.si

**South Africa**

Phone +27 10 060 0550  
E-Mail info@sickautomation.co.za

**South Korea**

Phone +82 2 786 6321/4  
E-Mail infokorea@sick.com

**Spain**

Phone +34 93 480 31 00  
E-Mail info@sick.es

**Sweden**

Phone +46 10 110 10 00  
E-Mail info@sick.se

**Switzerland**

Phone +41 41 619 29 39  
E-Mail contact@sick.ch

**Taiwan**

Phone +886-2-2375-6288  
E-Mail sales@sick.com.tw

**Thailand**

Phone +66 2 645 0009  
E-Mail marcom.th@sick.com

**Turkey**

Phone +90 (216) 528 50 00  
E-Mail info@sick.com.tr

**United Arab Emirates**

Phone +971 (0) 4 88 65 878  
E-Mail contact@sick.ae

**United Kingdom**

Phone +44 (0)17278 31121  
E-Mail info@sick.co.uk

**USA**

Phone +1 800.325.7425  
E-Mail info@sick.com

**Vietnam**

Phone +65 6744 3732  
E-Mail sales.gsg@sick.com

Detailed addresses and further locations at [www.sick.com](http://www.sick.com)

