

Q70NSC



Q70NSC

PRODUCT SPECIFICATION

Q70NSC

Materials Lens-AS, Housing-ABS

Ambient operating temperature -40°C to +50°C

Protection rating IP66

Flashing rate 60-80 flashes/min

- Ø70mm xenon lamp strobe signal lights
- High efficiency strobe light that offers excellent outdoor visibility and long-distance signal light luminance close to natural light
- Lamp connector fastening structure allows for convenient lamp replacement

Q70NSC Xenon Lamp Strobe Signal Lights

Model number	Voltage	Current	Certificates	Weight	Color
Q70NSC	AC110V	0.050A	-	0.19kg	<ul style="list-style-type: none"> ● R-Red ● A-Amber ● G-Green ● B-Blue

Technical Diagram

Units: mm

·Q70NSC

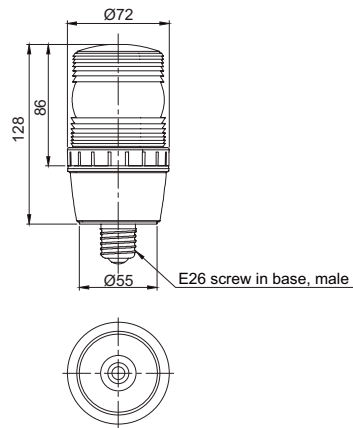

Wiring Instructions

· Edison screw bulb (E26) socket allows for easy and convenient wiring.



Ordering Specification

Q70NSC	-	110	-	A
[Model number] Q70NSC		[Voltage] 110-AC110V		[Color] <ul style="list-style-type: none"> ● R-Red ● A-Amber ● G-Green ● B-Blue