

# Warning Light Bars for Emergency Vehicle

## QLV

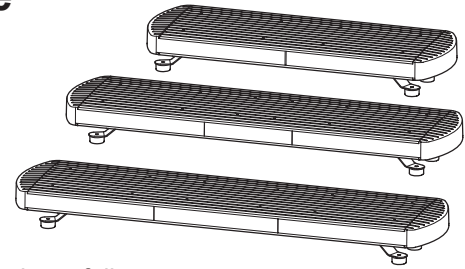
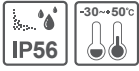

Thank you for purchasing Qlight's products. Please read this user manual carefully prior to installation and operation to ensure safe and correct use.

### ⚠️ Precautions for Safety

Failure to follow the instructions below may cause a loss of life or serious physical injury.

1. During wiring or maintenance, please completely turn off the power of the product. (Failure to follow this may lead to an electric shock.)
2. Do not install the product in locations that subjects it to excessive dust or water other than the conditions designated by the IP protection ratings indicated for each product. (Failure to follow these instructions may cause a fire to the product, electric shock, physical injury, malfunction or damage to the product.)
3. Do not alter or repair this product. If maintenance or repair service is required, please contact your local Qlight contact point. (Failure to follow these instructions may lead to fire, electric shock, or product damage.)
4. Please apply the correct voltage to the product. (Failure to follow these instructions may lead to fire, electric shock, or product damage.)
5. When the product is applied to a condition that may impact lives or property, please make sure to have a double safety device. (Failure to follow this may cause damage to property, fire, electric shock and loss of life.)

### ⚠️ Precautions for Correct Use

Failure to follow the proper instructions may cause damage to property, the product, or malfunction of the product that would void the warranty.

1. Please remove any objects that can interrupt ventilation around the product.
2. Please turn off the power of the product immediately if it fails to operate properly.
3. Carefully wire the product according to each product's specification.
4. Please be careful in preventing chemicals such as thinner, benzene, etc. in contact with the surface of the product.
5. Do not apply excessive force/impact to the product.
6. Failure to follow any of the instructions above may cause malfunction or damage to the product, fire, and electric shock.

### Ordering Specifications

QLV-1150	-	12	-	B/R
[Model number]		[Voltage]		[Color]
• QLV-1250		• 12-DC12V		• B/R - Blue-Red
• QLV-1150				• R/R - Red-Red
• QLV-885				• A/A - Amber-Amber
				• G/G - Green-Green

### Product Specifications

Model number	LED module number	Voltage	Current	Certificate	Weight	Color
QLV-1250	24EA	DC12V	7.2A	-	16.51kg	B(Blue)-R(Red)
QLV-1150	22EA		5.0A		15.62kg	R(Red)-R(Red)
QLV-885	18EA		3.5A		12.97kg	A(Amber)-A(Amber)
						G(Green)-G(Green)

- Protection rating : IP56
- Ambient operating temperature : -30°C to +50°C



Please scan the QR code for more detailed product information.

[www.qlight.com](http://www.qlight.com)

QLV-1250

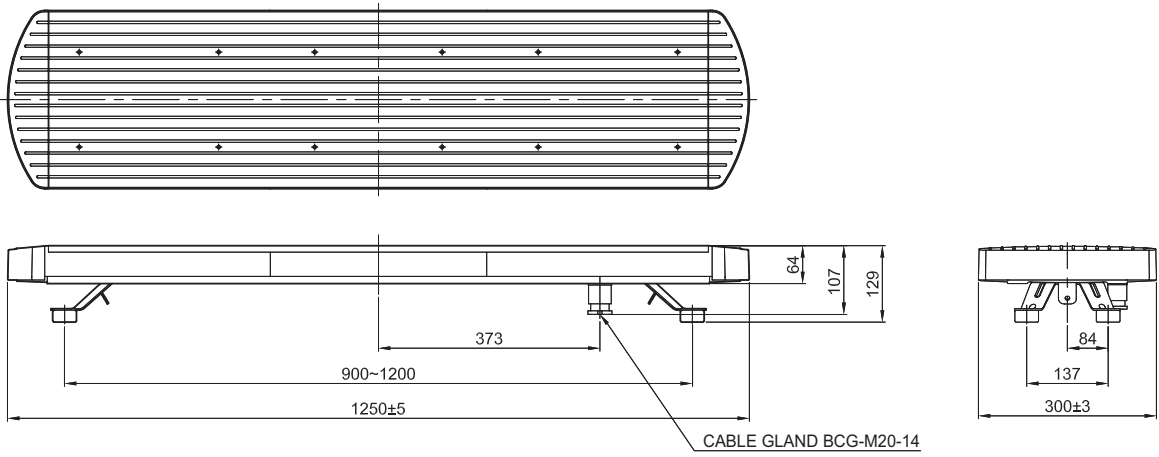

QLV-1150

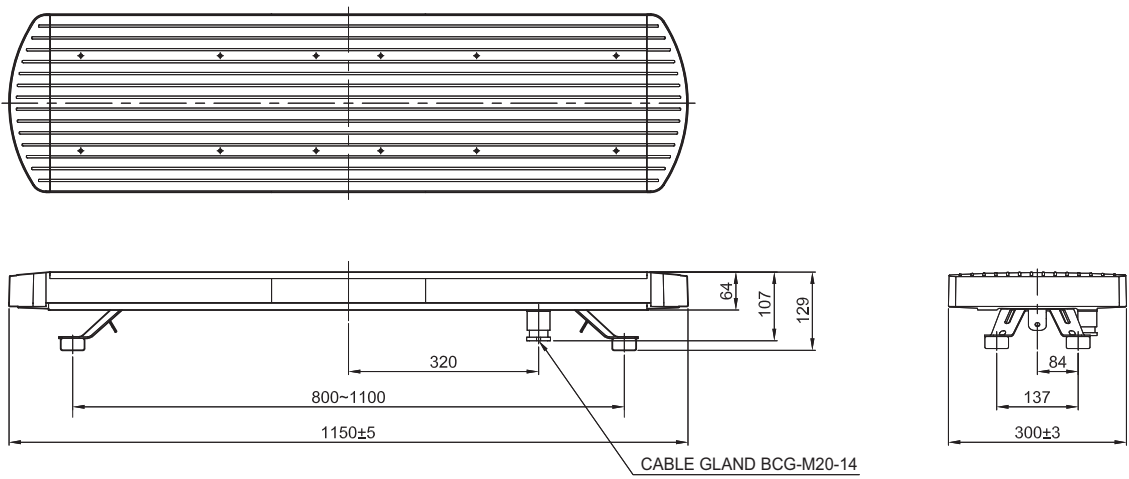

QLV-885

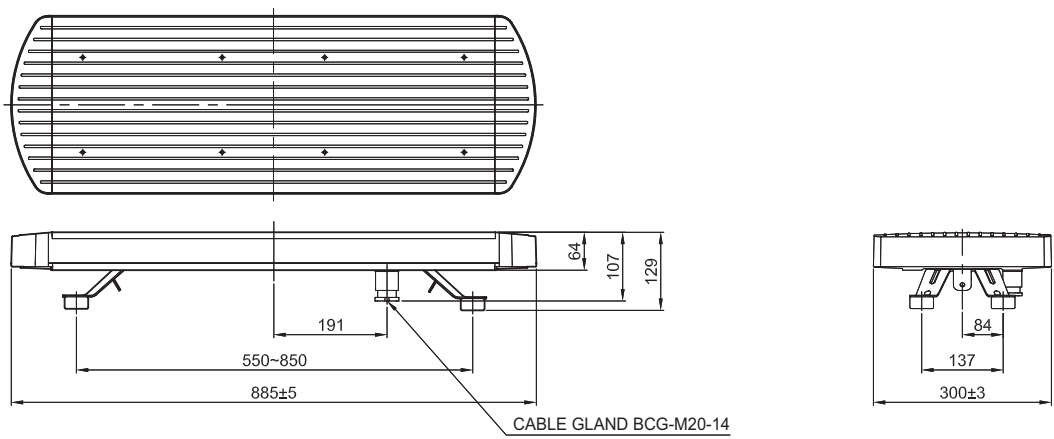

## Wiring Instructions

- The QLV warning light bar has a 10P connector.
- Refer to the pin map below for wiring instructions.

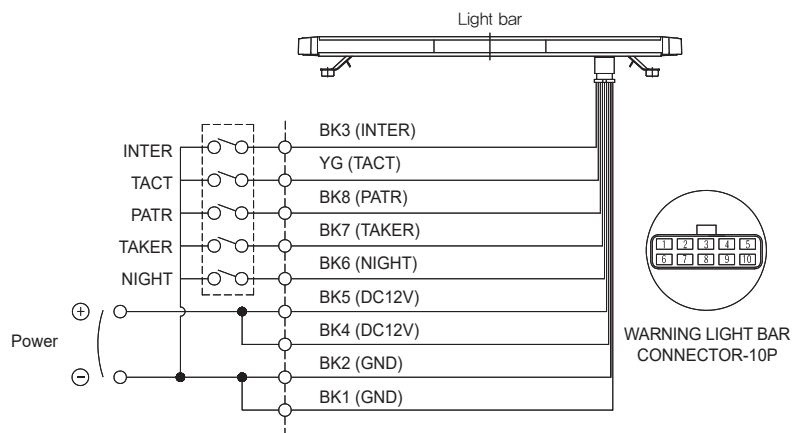

## Parts Definition/ Installation

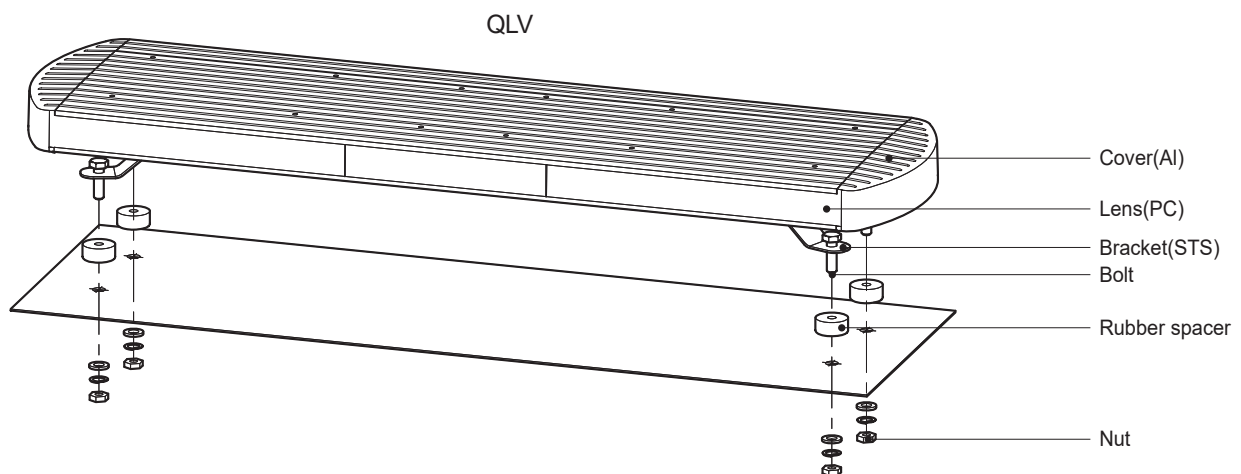

- First, machine taps or holes on the mounting surface .
- The mounting hole of this product is 9mm in diameter.
- Insert the bolt through the hole of the product, and tighten the nut from the opposite side of the mounting surface.
- Please fasten the nuts until the bolts are tightened securely.
- Use a flat washer and spring washer in the bolt assembly if the product will experience severe vibration and shock.

## Bracket Adjustment

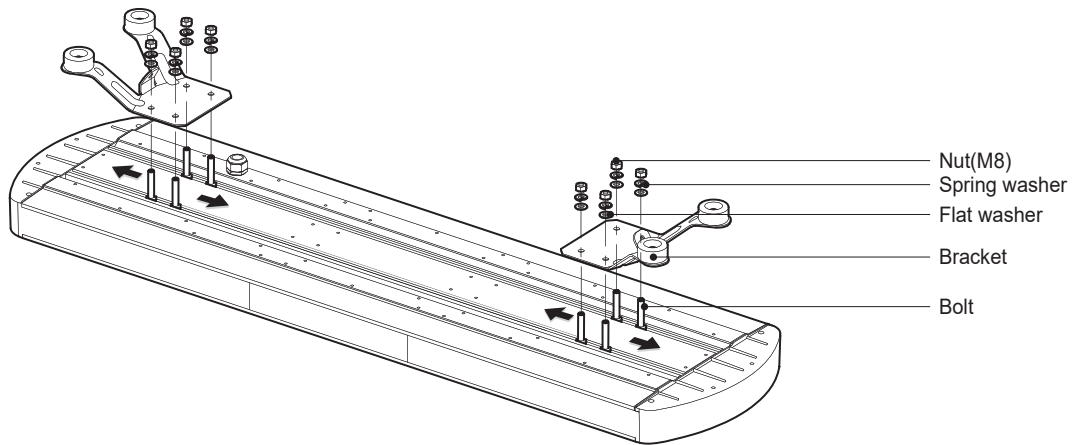

- To adjust the bracket location, please first remove the nuts(M8) that fasten the product and move the brackets to the desired location.
- After properly aligning the brackets to the desired pitch circular diameter (PCD) locations on the mounting surface, fasten the nuts until they tighten securely.

## Mounting Hole Specifications

- Machine holes on the mounting surface referring to the diagram below.

MODEL	A
QLV-1250	900-1200
QLV-1150	800-1100
QLV-885	550-850

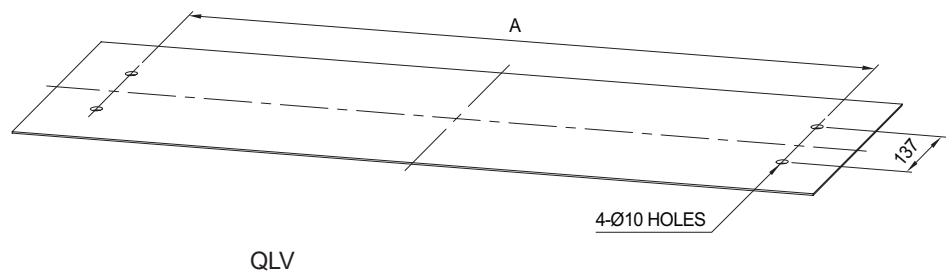

QLV

## Installation Environment and Protection Rating

- This product is designed for use with protection rating of IP56.
- If the product is installed in locations that subject it to excessive dust or water other than the designated IP protection rating indicated(IP56), it may cause malfunction or damage to the product.
- In case of outdoor applications, installation in the upright position or horizontal position are required and do not install the product upside-down where rain or moisture flow in.
- For further information, please visit our website([www.qlight.com](http://www.qlight.com)).

## Technical Certification

- Qlight products are designed to meet strict quality and technical standards. Thus, the Qlight brand is widely recognized for its high quality and technical innovations from leading institutions around the world.



### ISO International Organization for Standardization

Qlight quality assurance systems have been certified by ISO by applying the ISO 9001:2008, KS Q ISO 9001:2009 regulation.



### IECEX International Explosion Proof Certification (IECEX)

Certified that Qlight's products are being manufactured and manage according to international standards.



### ATEX The European Regulatory Framework or Manufacture, Installation and Use of Equipment in Explosive Atmospheres

Qlight's explosion proof products comply with ATEX Directives 94/9/EC.



### NEPSI National Supervision and Inspection Center for Explosion Protection and Safety of Instrumentation

Qlight's design and manufacturing system meets the People's Republic of China National explosion proof Standard. (Chinese Standard-GB3836/GB12476)



### KCs Explosion Proof Device Safety Certification System

The safety performance of machines and equipment subject to safety certification and Technical capability and production system have been certified safety certification standards.



### TIIS Japan Explosion-proof Certification

TIIS is a Japanes explosion proof test and certification system accordance with the Ministry of Health, Labour and Welfare Notice and the explosion proof guidelines for factory electrical equipment. Qlight's explosion proof products have been tested and certified by TIIS.



### CCS China Classification Society

Qlight's design and quality assurance system has been certified by the China Classification Society.



### RMRS Russian Maritime Register of Shipping

Qlight's design and quality assurance system has been certified from Russian Maritime Register of Shipping.



### LR Lloyd's Register

Qlight's design and quality assurance system has been certified from Lloyd's Register.



### KR Korean Register of Shipping

Qlight's design and quality assurance system has been certified by the Korean Register of Shipping.



### KC Korea Safety Certification

Qlight's products are certified by KC for preventing accident caused by fire.



### E-mark Commission Directive Regarding Vehicle Industry

Qlight has obtained EU mark for approved vehicles and vehicle components sold into the EU(EEA : European Economic Area)



### ICAO International Civil Aviation Organization

Qlight guarantees our products satisfy the criteria regulated by the International Civil Aviation Organization(ICAO, FAA).



### KCC Conformity Assessment of Broadcasting Communication Equipment

Qlight has been certified to protect the electromagnetic environment that causes unwanted electromagnetic waves from the device, communication failure due to other devices or external radio waves, and malfunction of the device.



### UL Underwriters Laboratories

Qlight's design and quality assurance system has been certified from UL to ensure the stability of consumption goods and to protect consumers.



### CCCF China Certification Center for Security & Protection

Qlight has passed the rigorous examination process of "Passing Fire Protection Products Centering" In order to sell fire-fighting products such as fire alarm equipment to Chinese market.



### CCC China Compulsory Certificate

Qlight's has obtained CCC which guarantees safety, protection against fraud, environment, etc.



### CE European Commission

Qlight has been certified by the European Commission.



### RoHS2 Restriction of Hazardous Substances Directive

Qlight c omplies with the Restriction of Hazardous Substances Directive by limiting its use of hazardous materials.







For your safety

Specification and dimensions listed in this catalogue subject to change without notice for product quality improvement.  
The newest product information is available on our website.(www.qlight.com)  
Please read the instruction manual attached to the product carefully before installation and use.

*Qlight Co., Ltd. www.qlight.com | trade@qlight.com*

Head Office | Suite #1510, STX-V Tower, 128 Gasan digital 1-ro, Geumcheon-gu, Seoul, Korea

Tel. +82-2-2679-6152(Toll free. +82-80-328-2222) Fax. +82-2-2679-6154

Factory | 185-25, Mukbang-ro, Sangdong-myeon, Gimhae-si, Gyeongsangnamdo, Korea Tel. +82-55-328-1111(Toll free. +82-80-328-1111)

Qlight OverSEAs Sales Dept | 704 Nakdong-daero, Sasang-gu, Busan, Korea(Eomgung-Dong) Tel : +82-51-620-4100

Qlight Public Relations & Marketing Team Office | 704 Nakdong-daero, Sasang-gu, Busan, Korea(Eomgung-Dong) Tel. +82-51-245-0017

---

*Qlight USA, Inc. www.qlight.com www.qlightusa.com | sales@qlightusa.com*

3003 North First Street, Suite #341, San Jose, CA 95134 USA Tel. +1-408-519-5740 Fax. +1-408-519-5739

---

*SHANGHAI Qlight Electronic Co., Ltd. www.qlight.com www.qlightcn.com | qlightcn@qlight.com*

China Factory/ Shanghai Sales Office | #19, Nanda Road, Baoshan Area, Shanghai, China Tel. +86-21-6651-7100 Fax. +86-21-6315-3929

China Factory Site 2 (Qidong) | #33, Haiyan Road, Qidong High-tech Industrial Development Zone, Qidong, Jiangsu Province, China

Tel +86-513-8384-9999 Fax +86-513-8384-9910

**Qlightec**

**Innovation in Alarm & Signal**

Product Operation Inquiry / Customer Support +82-51-620-4100

You can expect prompt service if you have exact information such as model name, symptom, telephone number and address.

※ ALL PRODUCT, PRODUCT SPECIFICATIONS AND DATA ARE SUBJECT TO CHANGE WITHOUT NOTICE TO IMPROVE RELIABILITY, FUNCTION OR DESIGN OR OTHERWISE.

Head office : Suite #1510, STX-V Tower, 128 Gasan digital 1-ro, Geumcheon-gu, Seoul, Korea (Postal Code : 08507)

Factory : 185-25, Mukbang-Ro, Sangdong-Myeon, Gimhae-Si, Gyeongsangnam-Do, Korea (Postal Code : 50805)

www.qlight.com

EN - QLV1250 - 2106A