

# Controllable AMP for Warning Light Bar

## SAMP

Signal sound AMP for ELML

### SAMP Controllable AMP for Warning Light Bar

Model number	Voltage	Current	Sound pattern	Frequency/Repeat time	Certificate	Weight
SAMP	DC12V DC24V	4.150A 1.870A	Fire	300-700Hz /140cycle	-	1.09kg
			Emergency	350-750Hz /14cycle		
			Ambulance	610-690Hz /50cycle		
			Buzzer	2,200Hz		
			Horn sound	595Hz-1,040Hz		



SAMP

- Simple linkage between sound signal and warning lights
- Clear and stable sound signal
- Built-in switch for emergency voice on the microphone

### Technical Diagram

Units: mm

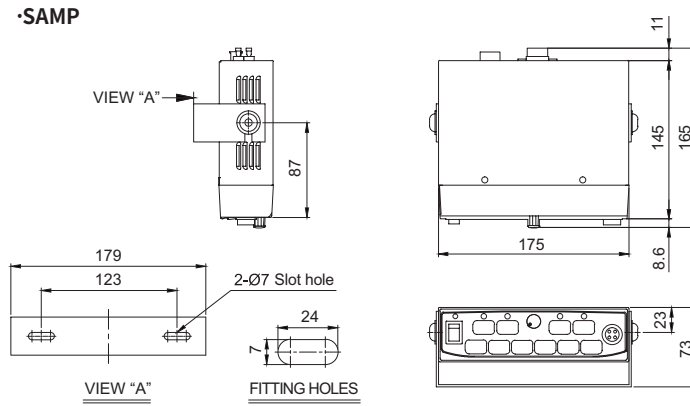

### Wiring Instructions

·SAMP-DC

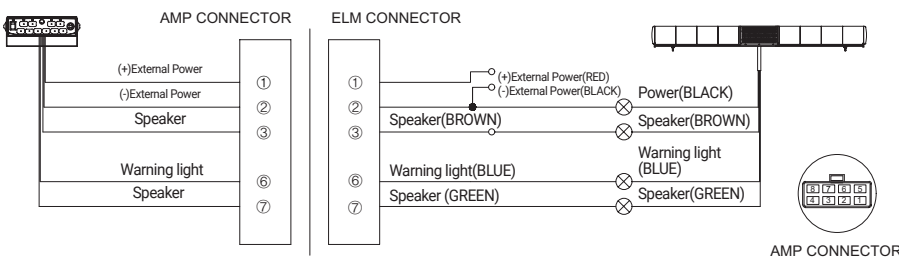

### Ordering Specification

