

QWL20/ QWL40

Water and Vibration LED Work Lights with IP67/ IP68K Protection

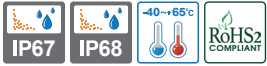

Water / Dust proof high brightness LED work light that resists against severe storm and heavily dusty environment



Common Specifications (QL98 series)

- Water / Dust proof LED work light that resists against severe storm and heavily dusty environment
- IP67/ IP68 protection rating, waterproof & dust resistant model that can be used where dusty and flooded area
- Polycarbonate lens allows excellent vibration and impact resistance.
- Long lifetime with a high intensity LED light source allows for easy maintenance
- Excellent durability that is suitable for harsh environment such as an excavator, crane, and off-road vehicle
- Materials : Housing: Al, Lens : PC
- Certificates : CE, UL



Test Conditions/ Regulations

Vibration Resistance Test	<ul style="list-style-type: none"> • Acceleration : 20m/s² • Duration : 1 octave/min • Range of frequency : 10-150Hz • Amplitude : 10 times maximum 7.5mm, direction : test 10times in 3 directions(X, Y, Z)
Shock Resistance Test	<ul style="list-style-type: none"> • Acceleration : 20g • Directions : ±X, ±Y, ±Z • Numbers : 3 times each directions • Time period : 11ms for each direction • Waveform : Half sine
Solid Particle Protection Test(IP6X)	<ul style="list-style-type: none"> • After reducing the pressure inside the test object, spray talcum powder with a nominal diameter of 50um for 2 hours at 40-60meters/hour inside the dust chamber. • IEC60529
Liquid Ingress Protection Test(IPX7)	<ul style="list-style-type: none"> • Test ingress by putting the object under 1000mm water with 2bar of pressure for 30 mins
Liquid Ingress Protection Test(IPX8)	<ul style="list-style-type: none"> • Much more strict than IPX7 protection rating and there must be an agreement between manufacturer and customer

QWL20

Water and Vibration LED Work Lights with IP67 Protection

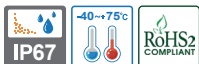

QWL20

Common Specifications

Optics Specifications

Model	QWL20
Lens color	Translucent
Light color	Cooldaylight
Color temperature	5,500-6,500 K
Luminous flux	1,000lm

Specifications

Model	QWL20
Voltage	DC12V-24V
Range for operation voltage	DC10V-30V
Power consumption	12W
Insulation resistance	Min. 50MΩ(500V DC mega ohm meter)
Withstanding voltage	DC : 500V AC, 60Hz, 1 minute
Operating temperature	-40°C to +75°C
Protection rating	IP67
Materials	Housing: Al, Lens : PC
Certificate	CE UL
Weight(Approx.)	0.40Kg

Technical Diagram

(Units : mm)

QWL20

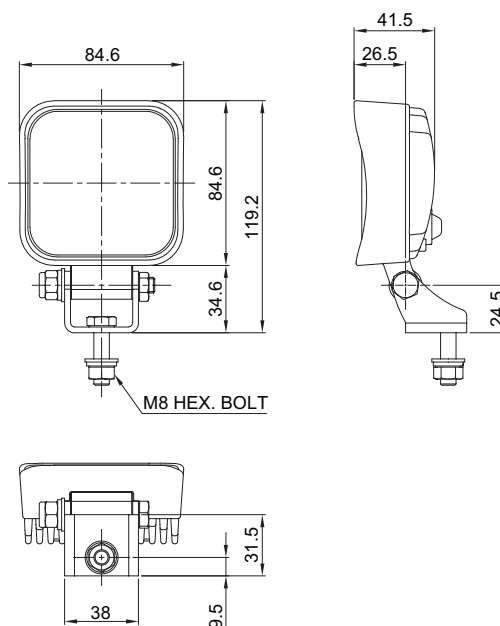

Ordering Specification

QWL20	-	12/24
[Model number]		[Voltage]
• QWL20		• 12/24-DC12V-24V

! Please read user manual carefully prior to operation to ensure safe and correct use. Failure to follow safety instructions may lead to electric shock because of fire and short circuit. Specification and dimensions listed in this catalogue subject to change without notice for product quality improvement. The newest product information is available on our website.