

ETG50L

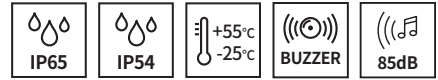

PRODUCT SPECIFICATION

ETG50L

Materials Housing-ABS, Lens-PC
Ambient operating temperature -25°C to +55°C
Volume Max. 85dB at 1m
Protection rating IP65/IP54

- 50mm outer diameter LED lighting economic tower lamp
- Vivid transmission of color using tinted lenses
- Excellent long-distance visibility by using high-brightness LED light source
- Waterproof and dustproof model that meets IP65 degree of protection
- Equipped with a foldable bracket to respond to various external environments
- Buzzer type can be selected for lighting specifications



ETG50L

ETG50L Industrial LED beacon

Model number	Layers	Voltage	Current	Certificates	Weight	Color
ETG50L Steady	3	DC24V	0.055A	-	0.42kg	● R-Red
ETG50L-BZ Steady w/built-in buzzer						● A-Amber
						● G-Green

Wiring Instructions

- ETG50L series can be wired by using both external contact and transistor.
- Wiring to transistor, use the PNP transistor. Please wire properly based on wiring instructions.

• ETG50L / ETG50L-BZ

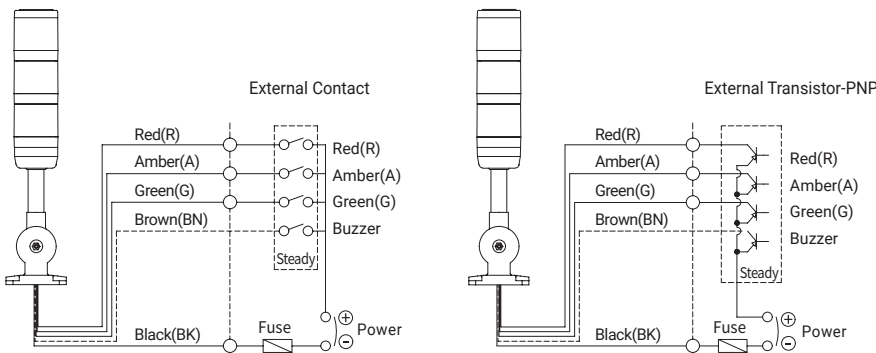

※ ETG50L / ETG50L-BZ: Steady

Technical Diagram

Units: mm

• ETG50L / ETG50L-BZ

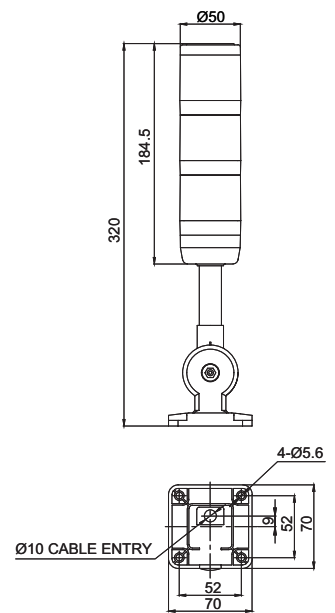

Ordering Specification

ETG50L	-	24	-	RAG
[Model number] ETG50L ETG50L-BZ		[Voltage] 24-DC24V		[Color] ● R-Red ● A-Amber ● G-Green