

flexLock

Safety locking device

SICK
Sensor Intelligence.



Described product

flexLock

Manufacturer

SICK AG
Erwin-Sick-Str. 1
79183 Waldkirch
Germany

Legal information

This work is protected by copyright. Any rights derived from the copyright shall be reserved for SICK AG. Reproduction of this document or parts of this document is only permissible within the limits of the legal determination of Copyright Law. Any modification, abridgment or translation of this document is prohibited without the express written permission of SICK AG.

The trademarks stated in this document are the property of their respective owner.

© SICK AG. All rights reserved.

Original document

This document is an original document of SICK AG.



Contents

1	About this document.....	6
1.1	Scope.....	6
1.2	Target groups of these operating instructions.....	6
1.3	Additional information.....	6
1.4	Symbols and document conventions.....	6
2	Safety information.....	8
2.1	General safety notes.....	8
2.2	Intended use.....	8
2.3	Improper use.....	8
2.4	Requirements for the qualification of personnel.....	9
3	Product description.....	10
3.1	Design and function.....	10
3.2	Product characteristics.....	10
3.2.1	Device overview.....	10
3.2.2	Locking principle.....	11
3.2.3	OSSD.....	11
3.2.4	Switching behavior of the OSSDs.....	11
3.2.5	Application diagnostic output.....	12
3.2.6	Coded actuators.....	12
3.3	Manual unlocking.....	12
3.3.1	Auxiliary release.....	12
3.3.2	Escape release.....	13
4	Project planning.....	14
4.1	Manufacturer of the machine.....	14
4.2	Operating entity of the machine.....	14
4.3	Design.....	14
4.3.1	Features of the actuator.....	14
4.3.2	Actuation direction and alignment of the actuator.....	16
4.3.3	Measures against accidental damage.....	17
4.3.4	Measures against manipulation.....	17
4.3.5	Preparing the mounting surface.....	17
4.4	Integration in the electrical control system.....	18
4.4.1	OSSDs.....	19
4.4.2	Safe series connection.....	20
4.5	Testing plan.....	21
5	Mounting.....	23
5.1	Orientation of the safety switch.....	23
5.2	Mounting several safety switches.....	23
5.3	Mounting the safety switch.....	23
5.4	Mounting the actuator.....	25

5.5	Mounting the escape release.....	26
6	Electrical installation.....	27
6.1	Notes on cULus.....	27
6.2	Device connection.....	27
6.3	Connection of a safe series connection.....	27
7	Commissioning.....	30
7.1	Teach-in.....	30
7.1.1	Teaching in the first actuator.....	30
7.1.2	Teaching in replacement actuators.....	31
7.2	Thorough check during commissioning and modifications.....	32
8	Operation.....	33
8.1	Actuating the auxiliary release.....	33
8.1.1	Moving the mechanical unlocking mechanism back after use.....	33
8.2	Actuating the escape release.....	33
8.2.1	Moving the escape release back after use.....	33
8.3	Preventing unintentional closing of the movable physical guard.....	33
9	Maintenance.....	35
9.1	Cleaning.....	35
9.2	Regular thorough check.....	35
10	Troubleshooting.....	36
10.1	LED displays.....	36
10.1.1	Indications when teaching in an actuator.....	37
10.1.2	Status indications during operation.....	37
10.1.3	Fault indications during operation.....	38
11	Decommissioning.....	40
11.1	Disposal.....	40
12	Technical data.....	41
12.1	Data sheet.....	41
12.2	Classification according to ZVEI, CB24I.....	44
12.3	Connecting cables.....	44
12.4	Safety switch dimensional drawings.....	44
12.5	Actuator dimensional drawings.....	47
12.6	Dimensional drawings of the mounting bracket.....	48
12.7	Dimensional drawings for extension pieces.....	48
12.8	Dimensional drawings for adapter plates.....	49
13	Ordering information.....	50
13.1	Scope of delivery.....	50
13.2	Ordering information.....	50

14	Accessories.....	51
14.1	Actuator.....	51
14.2	Connection technology.....	51
14.3	Mounting accessories.....	53
15	Annex.....	54
15.1	Conformities and certificates.....	54
15.1.1	EU declaration of conformity.....	54
15.1.2	UK declaration of conformity.....	54
15.1.3	FCC and IC radio approval.....	54

1 About this document

1.1 Scope

Product

This document applies to the following products:

- Product code: flexLock
- “Operating instructions” type label entry: 8025630

Document identification

Document part number:

- This document: 8020562
- Available language versions of this document: 8025630

You can find the current version of all documents at www.sick.com.

1.2 Target groups of these operating instructions

Some sections of these operating instructions are intended for certain target groups. However, the entire operating instructions are relevant for intended use of the product.

Table 1: Target groups and selected sections of these operating instructions

Target group	Sections of these operating instructions
Project developers (planners, developers, designers)	"Project planning", page 14 "Technical data", page 41
Installers	"Mounting", page 23
Electricians	"Electrical installation", page 27
Safety experts (such as CE authorized representatives, compliance officers, people who test and approve the application)	"Project planning", page 14 "Commissioning", page 30 "Technical data", page 41
Operators	"Troubleshooting", page 36
Maintenance personnel	"Troubleshooting", page 36

1.3 Additional information

www.sick.com

The following information is available on the Internet:

- Data sheets and application examples
- CAD data and dimensional drawings
- Certificates (e.g. EU declaration of conformity)
- Guide for Safe Machinery Six steps to a safe machine

1.4 Symbols and document conventions

The following symbols and conventions are used in this document:

Warnings and other notes



DANGER

Indicates a situation presenting imminent danger, which will lead to death or serious injuries if not prevented.

**WARNING**

Indicates a situation presenting possible danger, which may lead to death or serious injuries if not prevented.

**CAUTION**

Indicates a situation presenting possible danger, which may lead to moderate or minor injuries if not prevented.

**NOTICE**

Indicates a situation presenting possible danger, which may lead to property damage if not prevented.

**NOTE**

Highlights useful tips and recommendations as well as information for efficient and trouble-free operation.

Instructions to action

- ▶ The arrow denotes instructions to action.
- 1. The sequence of instructions for action is numbered.
- 2. Follow the order in which the numbered instructions are given.
- ✓ The check mark denotes the result of an instruction.

LED symbols

These symbols indicate the status of an LED:

- The LED is off.
- ◐ The LED is flashing.
- The LED is illuminated continuously.

2 Safety information

2.1 General safety notes

Integrating the product



DANGER

The product can not offer the expected protection if it is integrated incorrectly.

- ▶ Plan the integration of the product in accordance with the machine requirements (project planning).
 - ▶ Implement the integration of the product in accordance with the project planning.
-

Mounting and electrical installation



DANGER

Death or severe injury due to electrical voltage and/or an unexpected startup of the machine

- ▶ Make sure that the machine is (and remains) disconnected from the voltage supply during mounting and electrical installation.
 - ▶ Make sure that the dangerous state of the machine is and remains switched off.
-

Repairs and modifications



DANGER

Improper work on the product

A modified product may not offer the expected protection if it is integrated incorrectly.

- ▶ Apart from the procedures described in this document, do not repair, open, manipulate or otherwise modify the product.
-

2.2 Intended use

The safety locking device is a locking unit with a safety locking function and is suitable for the following applications:

- Temporarily preventing access to a hazardous area (protection of people)
- Monitoring of movable physical guards (protection of people)
- Locking for process protection

In conjunction with a movable physical guard and the machine controller, the safety locking device prevents the movable physical guard from being opened. The locking function remains active for as long as the hazardous machine function is performed or until the production step has finished.

The product may be used in safety functions.

The product is only suitable for use in industrial environments.

Incorrect use, improper modification of or tampering with the safety locking device will invalidate any warranty from SICK AG; in addition, any responsibility and liability of SICK AG for damage and secondary damage caused by this is excluded.

2.3 Improper use

The safety locking device is not suitable, among other things, for the following ambient conditions:

- Outdoor areas
- Residential areas
- Vacuum
- High pressure
- Strong UV exposure
- Near low-frequency RFID
- Near magnetic fields
- Increased radioactivity (> natural radioactivity)

2.4 Requirements for the qualification of personnel

The safety locking device must be planned in, installed, connected, commissioned, and serviced only by qualified safety personnel.

Project planning

You need safety expertise to implement safety functions and select suitable products for that purpose. You need expert knowledge of the applicable standards and regulations.

Mounting, electrical installation and commissioning

You need suitable expertise and experience. You must be able to assess if the machine is operating safely.

Operation and maintenance

You need suitable expertise and experience. You must be instructed in machine operation by the machine operator. For maintenance, you must be able to assess if the machine is operating safely.

3 Product description

3.1 Design and function

Design

The safety locking device is a locking unit with a safety locking function. The safety locking device consists of a safety switch with RFID monitoring and a coded actuator.

Function

The safety locking device is used on a movable physical guard. The safety switch is located on the frame of the movable physical guard, the actuator on the moving part. When the movable physical guards closes, the actuator is inserted into the safety switch. The safety switch reads the code of the actuator. If the code is valid, the safety locking function can be locked via a signal. The movable physical guard is held closed.

3.2 Product characteristics

3.2.1 Device overview

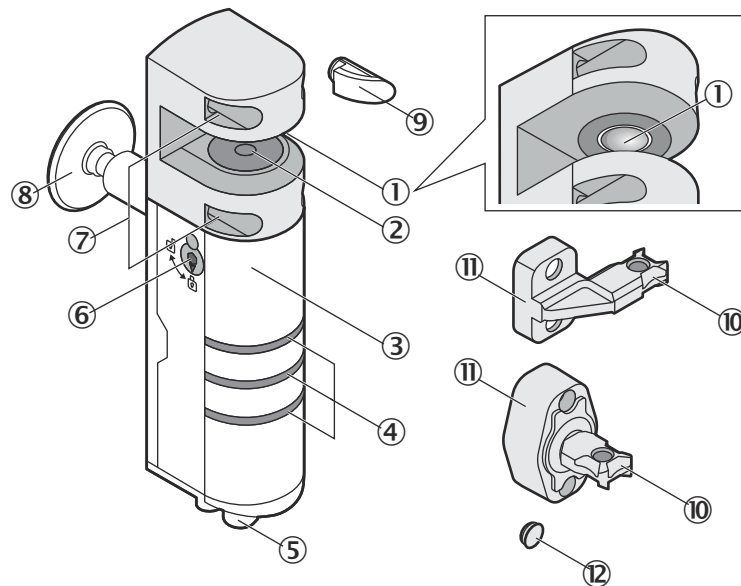

Figure 1: Device overview

- ① Retaining ball
- ② Locking pin
- ③ safety switch
- ④ LED display
- ⑤ Connection
- ⑥ Auxiliary release
- ⑦ Mounting holes
- ⑧ Escape release
- ⑨ Protective cap for mounting holes of the safety switch
- ⑩ Actuator tongue
- ⑪ Mounting plate of the actuator
- ⑫ Protective cap for actuator mounting holes

3.2.2 Locking principle

Overview

The method of locking depends on the safety locking device variant selected. There are two variants:

- Power to lock
- Power to release

Power to lock

- Activating the locking function: voltage at locking function input
- Deactivating the locking function: no voltage at locking function input

If the voltage is interrupted, the locking function is deactivated and the movable physical guard can be opened immediately.



DANGER

Hazard due to lack of effectiveness of the protective device

For power to lock variants only: In the event of a voltage drop, the locking function is deactivated regardless of whether the dangerous state of the machine has ended.

- ▶ Do not use the safety switch in applications in which the dangerous state cannot be ended immediately (stopping/run-down time).

Power to release

- Activating the locking function: no voltage at locking function input
- Deactivating the locking function: voltage at locking function input

If the voltage is interrupted, the locking function retains its last state (bistable solenoid). If the locking function was activated before, the movable physical guard cannot be opened. If the locking function was deactivated before, the movable physical guard can be opened.

Only the power to release variants have an auxiliary release.

3.2.3 OSSD

Output signal switching device: signal output for the protective device, which is used for stopping the dangerous movement.

An OSSD is a safety switching output. The functionality of each OSSD is tested periodically. OSSDs are always connected in pairs and must undergo dual-channel analysis for safety reasons. An OSSD pair is formed from 2 OSSDs that are connected and analyzed together.

3.2.4 Switching behavior of the OSSDs

Overview

The safety locking device is available in variants for protecting people or for process protection. The variants differ with regards to the switching behavior of the OSSDs.

Variants for protecting people (locking monitoring)

OSSDs go into the ON state when the following conditions are all met.

- Movable physical guard is closed.
- Locking function is activated.
- A valid signal is present at the inputs In1 and In2.

Variants for process protection (actuator monitoring)

OSSDs go into the ON state when the following conditions are all met.

- Movable physical guard is closed.
- A valid signal is present at the inputs In1 and In2.

Important information



DANGER

Hazard due to lack of effectiveness of the protective device

- ▶ Do not use variants for process protection in applications where the dangerous state cannot be ended immediately (stopping/run-down time).
-

3.2.5 Application diagnostic output

Important information



NOTE

The application diagnostic output cannot be evaluated for a safe series connection with T-connectors.

Switching behavior

The application diagnostic output switches depending on the detection of the actuator. This is not a safety output.

Status of the movable physical guard	Switching behavior of the application diagnostic output
Open	OFF
Closed	ON

3.2.6 Coded actuators

The safety locking device comes with RFID-coded actuators.

- Uniquely coded
Only one actuator is valid at any one time. Actuators need to be taught-in to become valid. Each time a new actuator is taught-in, the previous actuator becomes invalid.
Coding level: High (ISO 14119)
- Universally coded
The device accepts all actuators that are suitable for the device.
Coding level: Low (ISO 14119)

3.3 Manual unlocking

In some situations, it necessary to unlock the locking device manually (e.g. if faults are present). When unlocking, the safe output signal switching devices (OSSD) switch to the OFF status. A stop command must be generated as a result.

After manual unlocking, a function check-out must be performed ([see "Testing"](#)).

3.3.1 Auxiliary release

Using the auxiliary release, the safety locking device can be manually unlocked regardless of the status.

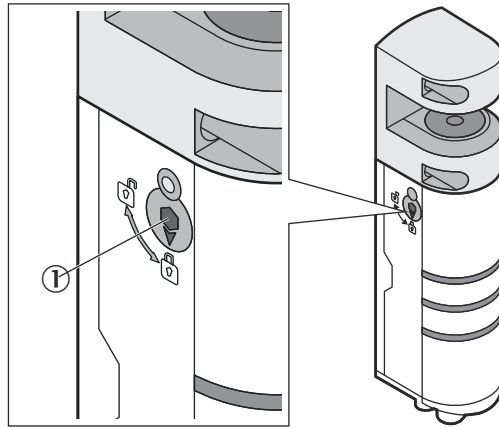

Figure 2: Position of the auxiliary release

- ① Auxiliary release

Only the power to release variants have an auxiliary release.

3.3.2 Escape release

The escape release makes it possible to open a closed movable physical guard without tools from within the hazardous area.



WARNING

- The escape release must be able to be actuated manually from inside the protected area without tools.
- Mount the escape release so that actuation can only take place from inside of protected area (hazardous area).

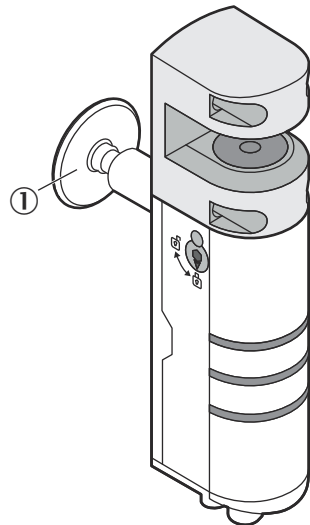

- ① Escape release

4 Project planning

4.1 Manufacturer of the machine

The manufacturer of the machinery must carry out a risk assessment and apply appropriate protective measures. Further protective measures may be required in addition to the product.

The product must not be tampered with or changed, except for the procedures described in this document.

The product must only be repaired by the manufacturer of the product or by someone authorized by the manufacturer. Improper repair can result in the product not providing the expected protection.

Observe EN ISO 14119 for using interlocking devices associated with physical guards.

4.2 Operating entity of the machine

Changes to the electrical integration of the product in the machine controller and changes to the mechanical mounting of the product necessitate a new risk assessment. The results of this risk assessment may require the entity operating the machine to meet the obligations of a manufacturer.

After each change to the configuration, it is necessary to check whether the protective measure provides the necessary protection. The person making the change is responsible for ensuring that the protection measure provides the necessary protection.

The product must not be tampered with or changed, except for the procedures described in this document.

The product must not be repaired. Defective products must be replaced.

Restrict access to replacement actuators, so they cannot be used for bypassing.

4.3 Design

4.3.1 Features of the actuator

The actuator is available in different designs.

- Rigid actuator
- Flexible actuator

Table 2: Features of the actuator

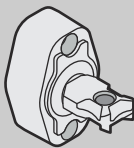
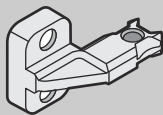
	Flexible actuator	Rigid actuator
		
Alignment of actuator to mounting surface	Straight	Angled
Rotatable and spring-loaded actuator	Yes	No

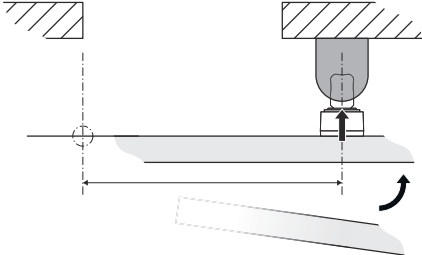
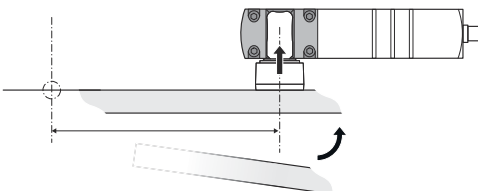
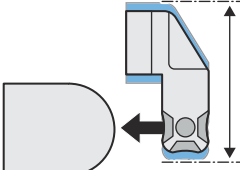
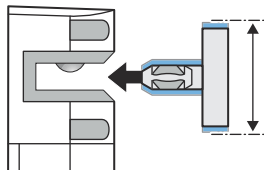
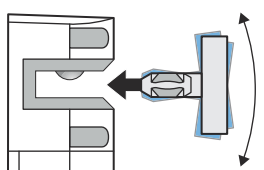
	Flexible actuator	Rigid actuator
<p>Minimum door radius for door stop on left or right of device</p> 	180 mm	150 mm
<p>Minimum door radius for door stop above the device</p> 	500 mm	800 mm
<p>Max. horizontal offset</p> 	3 mm	0.5 mm
<p>Max. vertical offset</p> 	3 mm	0.5 mm
<p>Max. offset angle about the X-axis</p> 	2.5°	0°

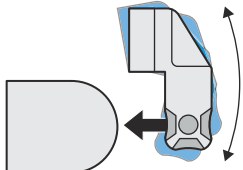
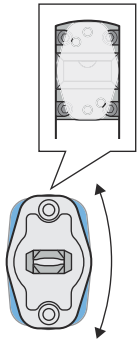
	Flexible actuator	Rigid actuator
Max. offset angle about the Y-axis 	2.5°	0°
Max. offset about the Y-axis 	2.5°	0°

4.3.2 Actuation direction and alignment of the actuator

Actuating direction

The safety locking device can be actuated horizontally within a 180° radius with infinite adjustment.

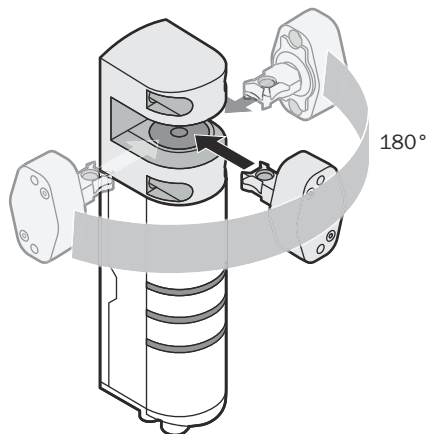
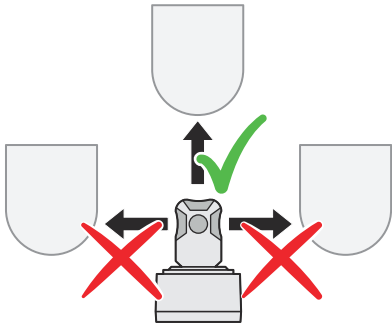
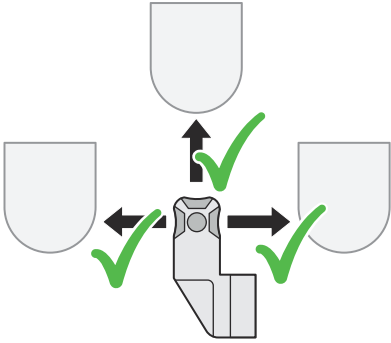

Figure 3: Possible actuating directions

Alignment of the actuator to the safety locking device

Flexible actuator	Rigid actuator
The flexible actuator can only be inserted with the front part of the actuator tongue.	The rigid actuator can be inserted in the front or the side.
 <p><i>Figure 4: Actuation direction of flexible actuator</i></p>	 <p><i>Figure 5: Actuation direction of rigid actuator</i></p>

4.3.3 Measures against accidental damage

You can use the following measures to avoid unintentional damage to the safety switch:

- Select the mounting location so that the safety switch is protected from impacts and mechanical pressure.
- Fit an additional stop for the door. The safety switch must not be used as a stop.

4.3.4 Measures against manipulation

The safety switch must not be defeated (contacts jumpered), rotated away, removed, or rendered ineffective in any other way. You must put measures in place, if necessary, to reduce the possibilities for circumventing the device.

4.3.5 Preparing the mounting surface

Overview

If the safety locking device is used without mounting brackets, appropriate holes must be provided in the mounting surface. The necessary drill holes can be seen from the dimensional drawings of the safety switch.

For variants with escape release, the maximum wall thickness must be taken into account.

Maximum wall thickness

It must be possible to reset the escape release after actuation. The button of the escape release must therefore not lie flat after actuation. The wall thickness of the mounting surface must therefore be max. 34 mm.

Using extension pieces, the axis of the escape release can be extended in 30 mm increments. This enables the maximum wall thickness to be increased to 64 mm or 94 mm.

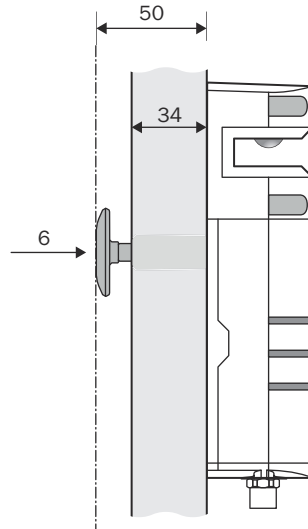

Figure 6: Maximum wall thickness of the mounting surface (without extension pieces)

Further topics

- ["Safety switch dimensional drawings", page 44](#)

4.4 Integration in the electrical control system

You need to take the following into consideration when integrating the safety locking device into the electrical control system.

Requirement for use

- The safety locking device must not be bypassed by electrical means, e.g. by bridging the contacts. You may need to take measures to prevent this.
- The connected controller and all devices responsible for safety must comply with the required performance level and the required category (for example according to ISO 13849-1).
- The overall concept of the control system in which the device is integrated must be validated in accordance with ISO 13849-2.
- The inputs of a connected evaluation unit must be positive-switching (PNP) inputs because the two outputs of the safety switch supply a level of the supply voltage in the switched-ON state.

Generating the signals for the safety locking device

- For variants for protecting people only: The locking function may only be deactivated when the dangerous state has ended. Depending on the safety concept, the signal is analyzed, for example, by a safety relay or a safety controller.
- Use control without test pulses. The safety switch generates its own test pulses.

Evaluating the signals from the safety locking device

- In the closed or locked state, the OSSDs signal the ON state with the signal level HIGH (non-isolated). When opened or unlocked or there is a device fault, the OSSDs signal the OFF state with the signal level LOW.
- Downstream control elements must evaluate the output signals of the safety switch in such a way that the dangerous state of the machine is safely ended. The machine switches to the safe state if, at any time, at least one OSSD in the OSSD pair switches to the OFF state.
- Switch-on commands that put the machine in a dangerous state may only be activated when the OSSDs of the safety locking device are in the ON state.

- Closing or locking the movable physical guard must not trigger the automatic starting of a hazardous machine function. This must occur by means of a separate start command.
- The safety switch tests the OSSDs at regular intervals. To do this, the safety switch switches each OSSD briefly (for max. 300 μ s) to the OFF state and checks whether this channel is voltage-free during this time. Make sure that the machine's control does not react to these test pulses and the machine does not switch off.

4.4.1 OSSDs

Overview

You can integrate the safety component directly into the machine controller via the safety outputs (OSSDs). The OSSDs indicate the ON state with the HIGH signal level (non-isolated). The OFF state is indicated with the LOW signal level.

Downstream control elements must evaluate the output signals of the safety component in such a way that the dangerous state of the machine is safely ended. Depending on the safety concept, the signal is analyzed by, e.g., safety relays or a safety controller.

Isolated connection of OSSD1 and OSSD2

- It must be possible to electrically influence the control of the machine.
- The electrical control of the machine must meet the requirements of IEC 60204-1.
- When using a safety controller, different signal levels of both OSSDs must be detected depending on applicable national regulations or required reliability of the safety function. The maximum discrepancy time tolerated by the controller must be selected according to the application
- The OSSD1 and OSSD2 output signals must not be connected to each other.
- In the machine controller, the signals of both OSSDs must be processed separately.

Avoiding any potential difference between the load and safety component

If you connect loads to the output signal switching devices (switching outputs) that then also switch if controlled with negative voltage (e.g., electro-mechanical contactor without reverse polarity protection diode), you must connect the 0 V connections of these loads and those of the corresponding protective device separately and also directly to the same 0 V terminal strip. In the event of a fault, this is the only way to ensure that there can be no potential difference between the 0 V connections of the loads and those of the corresponding safety component.

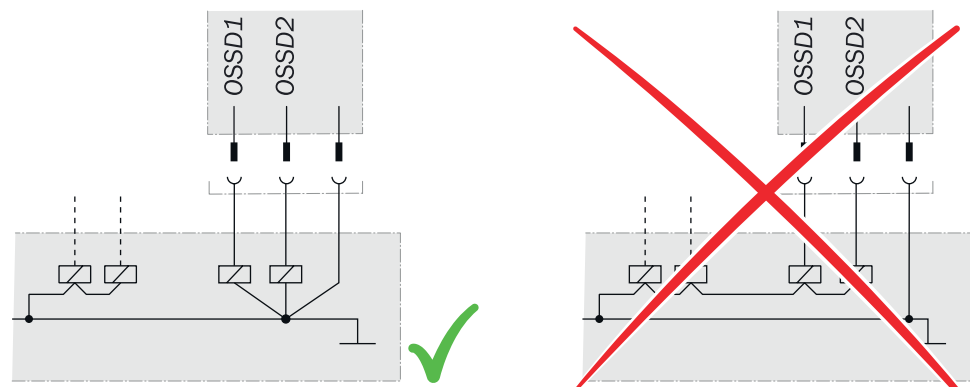

Figure 7: No potential difference between the load and safety component

4.4.2 Safe series connection

Overview

Several safety switches can be connected in series in a safe series connection. The type of safe series connection depends on the safety switch variant selected.

The following options are available:

- Safe series connection with Flexi Loop (with diagnostics)
In a series connection with Flexi Loop, the safety switches are connected to Flexi Loop nodes and evaluated by the associated safe evaluation unit from SICK. When connecting locking devices to Flexi Loop, the output monitoring and cross-circuit protection from AUX IN to AUX OUT of the respective Flexi Loop node must be deactivated.
- Safe series connection with T-connector (without diagnostics)
In a series connection with T-connectors, several safety switches are connected via T-connectors and connected to the safe evaluation unit. The connected devices act like a single device.
- Safe series connection in control cabinet (with diagnostics)
In a series connection in the control cabinet, the safety switches are led to the control cabinet individually. The OSSDs of the safety switches are connected in series there and evaluated by the evaluation unit. The Aux outputs can be individually connected to the programmable logic controller (PLC).

Safe series connection with T-connectors or in the control cabinet

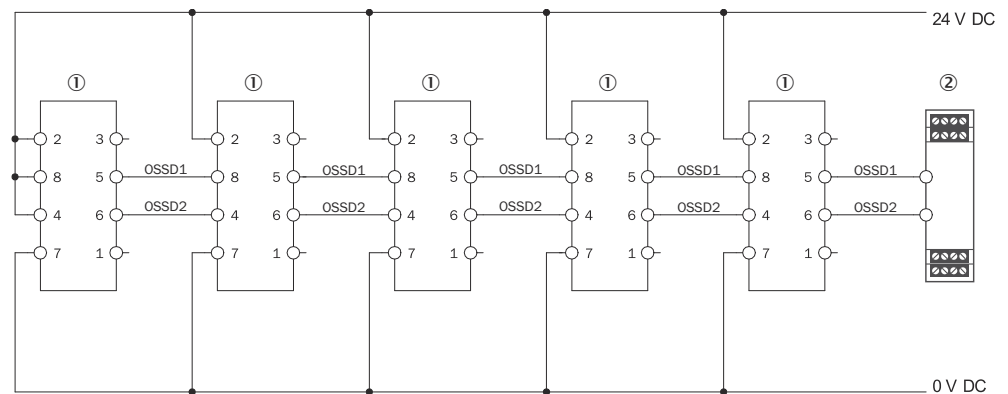

Figure 8: Switching with 5 safety switches connected in series

- ① Safety switch
- ② Safe evaluation unit

The voltage drop in the series connection must be checked so that the defined minimum voltage is still applied to the last safety switch.

For connection cables with a length of 2 m and a conductor cross section of 0.25 mm², the maximum number of safety switches in connected in series depends on the voltage as follows:

Table 3: Maximum number of safety switches in a series connection depends on the voltage

Voltage	Connection cables, for series connection	Input voltage at the last Safety switches	Maximum number of safety switches in series connection
24 V	Length: 2 m	19.2 V	4
26 V	Conductor cross section <ul style="list-style-type: none"> • General: 0.34 mm² • Between the safety switch and series connection nodes: 0.25 mm² 	19.5 V	5

Complementary information

Number of safety locking devices in a safe series connection

The maximum number of safety locking devices in a safe series connection depends on the following factors:

- Technical implementation of the safe series connection (T-connector, Flexi Loop, or series connection in the control cabinet)
- Applied supply voltage
- Length of cables used
- conductor cross section of cables used
- Load current
- Required performance level

The number of safety locking devices in a safe series connection affects the response times of the system (see "Data sheet", page 41).

4.5 Testing plan

Overview

The manufacturer of the machine and the operating entity must define all required thorough checks. The definition must be based on the application conditions and the risk assessment and must be documented in a traceable manner.

Important information



DANGER

Insufficient checks or incorrect repair

Hazard due to lack of effectiveness of the protective device

- ▶ Replace safety switch and actuator if damaged or worn. Never replace individual parts or assemblies.
- ▶ Check the safety switch at the inspection intervals specified in the national rules and regulations.

Defining the thorough check

- ▶ When defining the thorough check, please note the following:
 - Define the type and execution of the thorough check.
 - Define the frequency of the thorough check.
 - Notify the machine operators of the thorough check and instruct them accordingly.

The following thorough checks are often defined in connection with a protective device:

- Thorough check during commissioning and modifications
- Regular thorough check

Minimum requirements for the thorough check

The following thorough checks must be done to ensure permanent and proper function:

- Proper switching function
- Safe mounting of all components
- No damage, contamination, deposits or wear
- No loose plug connectors
- No signs of manipulation
- For safety switches with taught-in actuators: The actuators used are taught-in actuators.

5 Mounting

5.1 Orientation of the safety switch

The safety switch can be mounted with any alignment.

5.2 Mounting several safety switches

If several safety switches are mounted, they must be mounted at a minimum distance to one another.

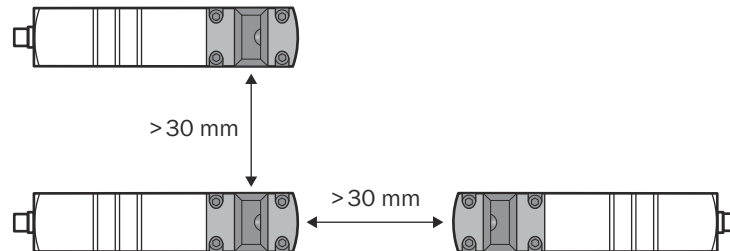

Figure 9: Minimum distance of safety switches

5.3 Mounting the safety switch

Important information



NOTICE

- Arrange the safety switch and actuator so that damage due to unintentional outside influences is prevented.
- Protect the switch head against damage and ingress of foreign bodies, e.g., chips, sand, abrasives, etc.
- Check for environmental influences before using the safety locking device, e.g., UV radiation or corrosion. Mount with protection if necessary.

Prerequisites

- Project planning is completed.
- Assembly is carried out according to the project planning.
- Dangerous condition of the machine is and remains switched off during mounting.
- Do not use a safety switch and actuator as a stop.
- The set-up and mounting of the safety switch and actuator must be stable enough to maintain proper operation.
- Use only reliable mounting elements that can only be removed with tools.
- When using a custom bracket: Ensure that the bracket can absorb at least the same level of mechanical forces that the safety locking device can absorb when the locking function is active.

Procedure

1. Select a position for the safety switch on the fixed part of the movable physical guard, e.g., on the door frame. The safety switch must be positioned in such a way that the actuator is inserted into the safety switch when the movable physical guard closes.
2. Connect the safety switch to the fixed part of the movable physical guard.

Minimum requirement for mounting screws

- Quantity: 4
 - Size: M5 × 25 (or longer)
 - Strength class: Class 8.8 or higher (stainless steel screws: A2-70 or higher).
 - Tightening torque: 5 Nm
3. Apply an at least medium-strength, material-bonded screw adhesive.
 4. Place the protective cap at a 45° angle to the mounting hole.

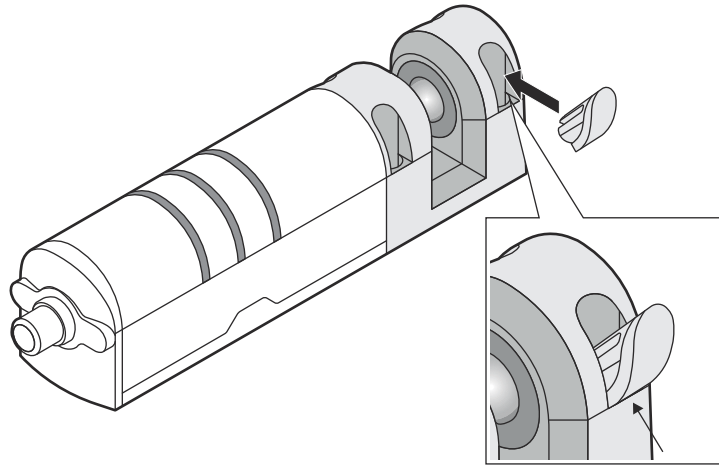

Figure 10: Put on protective cap.

5. Screw in protective cap and press down firmly. Use tool to press down if necessary.

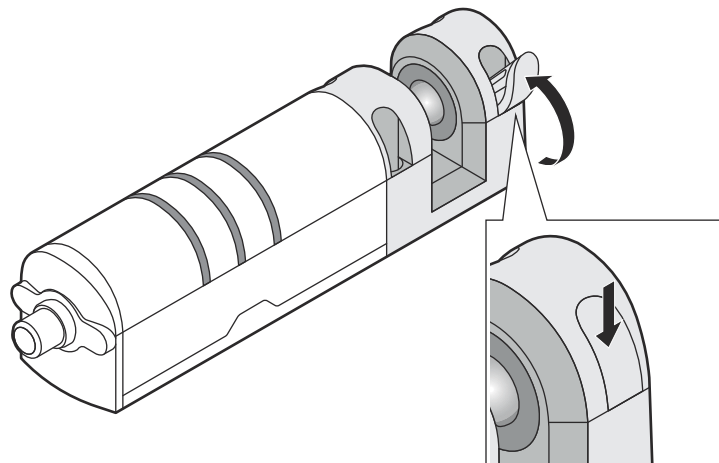

Figure 11: Screw in protective cap and press down firmly.

6. Repeat steps 4 and 5 for all protective caps.

Complementary information

The safety switch can be mounted on an aluminum profile using the optional mounting bracket.

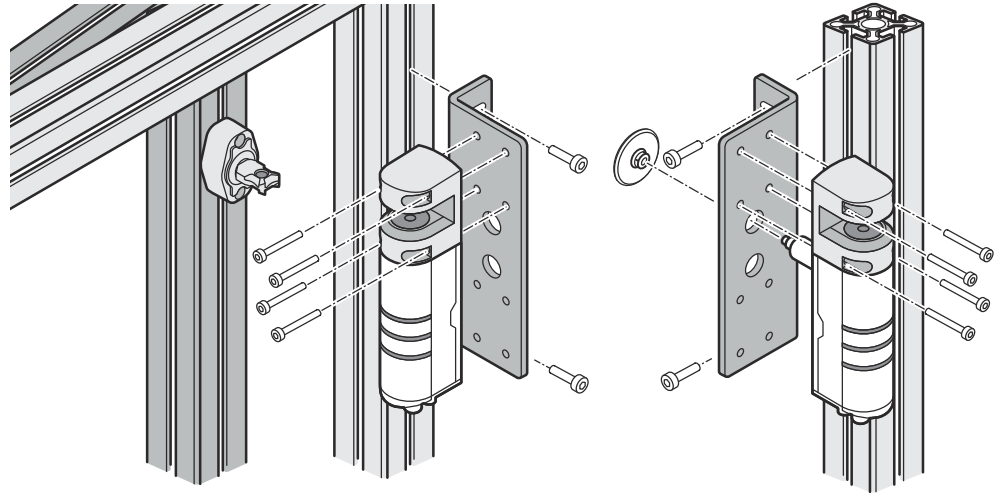

Figure 12: Mounting using the optional mounting bracket

Minimum requirement on the screws for mounting the mounting bracket

- Size: M6
- Stainless steel screws: A2-70 or higher
- Tightening torque: 5 Nm
- Apply an at least medium-strength, material-bonded screw adhesive.
- Screws are protected against manipulation, e.g., with screw covers. The mounting bracket cannot be removed.

5.4 Mounting the actuator

Procedure

1. Select a position for the actuator on the movable physical guard. Select the position in such a way that the actuator is inserted into the safety switch when the movable physical guards closes.
For flexible actuators, the actuator tongue can be rotated in 90° increments if necessary. To do so, press and rotate the actuator tongue in the actuator.
2. Attach the actuator to the movable physical guard.

Minimum requirement for mounting screws

- Design: Use one way screws to make unauthorized removal of the actuator difficult (manipulation protection).
- Quantity: 2
- Size

Actuator	Size
Flexible	M5 × 25 (or longer)
Rigid	M5 × 14 (or longer)

- Strength class: Class 8.8 or higher (stainless steel screws: A2-70 or higher).
 - Tightening torque: 5 Nm
3. Apply an at least medium-strength, material-bonded screw adhesive.
 4. Close mounting holes with protective caps.

5.5 Mounting the escape release

Prerequisites

- Hole in the mounting surface for the escape release (see "[Preparing the mounting surface](#)", page 17).
- 30 mm long extension piece for the axis of the escape release (optional). Use only original extension pieces from SICK.

Procedure

1. If necessary, extend the axis of the escape release using extension pieces (max. 2 extension pieces). Threadlocker is already applied to the threads of the extension pieces.
Only if the escape release has previously been removed: Apply medium-strength threadlocker to the thread of the escape release and the thread of the extension pieces.
2. Insert the axis of the escape release through the hole.
3. Mount the safety switch using 4 × M5 screws.
4. Screw on the red button of the escape release.

6 Electrical installation

6.1 Notes on cULus

For use according to the requirements of UL 60947-5-2, the following conditions must also be met:

- The voltage supply must conform to Class 2 according to UL 508.
- The required fuse protection for each device is 2 A. In a safe series connection, a suitable device fuse protection must be calculated.

6.2 Device connection

Prerequisites

- Mounting is completed.
- Electrical installation is carried out according to the project planning.
- Dangerous condition of the machine is and remains off during the electrical installation.
- Outputs of the device have no effect on the machine during electrical installation.

Device connection (M12, 8-pin)

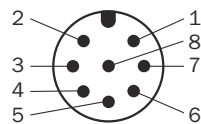

Figure 13: Device connection (male connector, M12, 8-pin, A-coded)

Table 4: Device connection pin assignment (male connector, M12, 8-pin, A-coded)

PIN	Wire color ¹⁾	Designation	Description
1	White	Out AUX	Application diagnostic output (not safe)
2	Brown	+24 V DC	Supply voltage 24 V DC
3	Green	LOCK	Locking device input
4	Yellow	In 2	Enable input for OSSD 2 ²⁾
5	Gray	OSSD 1	OSSD 1 output
6	Pink	OSSD 2	OSSD 2 output
7	Blue	0 V	Supply voltage 0 V DC
8	Red	In 1	Enable input for OSSD1 ²⁾

¹⁾ Applies to the extension cables recommended as accessories.

²⁾ When used as an individual safety locking device or as the first safety locking device in a safe series connection, apply 24 V DC.

6.3 Connection of a safe series connection

Overview

The safe series connection can be implemented using special T-connectors and an end connector. The safe evaluation unit switches off the machine in case of the following events:

- A safe locking function is deactivated (for variants with locking monitoring).
- A movable physical guard is opened.
- Error on a safety locking device

Important information



NOTE

- In the case of safety locking devices cascaded with T-connectors, the application diagnostic output (Out AUX) cannot be evaluated.
- Mount the connecting cable so that individual T-connectors (and thus a safety locking device) cannot be easily jumpered.

Connection of the safe series connection (M12, 5-pin)

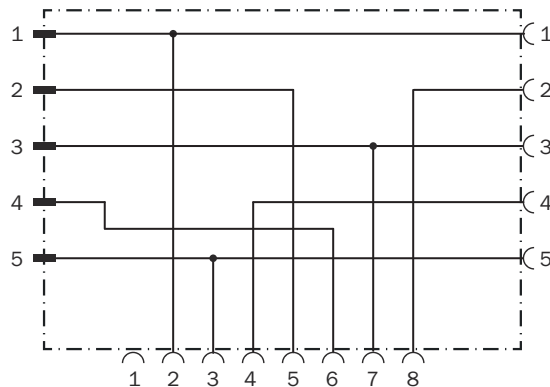

Figure 14: Internal circuitry: T-connector for safe series connection

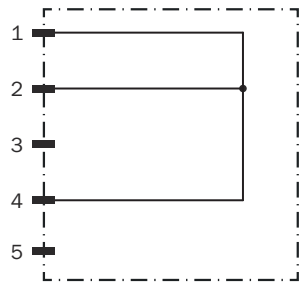

Figure 15: Internal circuitry: end connector for safe series connection

The 5-pin male connector of the last T-connector upstream of the safe evaluation unit is the interface between the safe series connection and the safe evaluation unit.

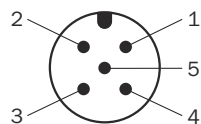

Figure 16: Connection of the T-connector (M12, 5-pin, A-coded, male connector)

Table 5: Pin assignment for the T-connector (M12, 5-pin, A-coded, male connector)

PIN	Wire color ¹⁾	Designation	Description
1	Brown	+24 V DC	Supply voltage 24 V DC
2	White	OSSD 1	OSSD 1 output
3	Blue	0 V	Supply voltage 0 V DC
4	Black	OSSD 2	OSSD 2 output
5	Gray	Lock	Locking function input

¹⁾ Applies to the extension cables recommended as accessories.

Further topics

- ["Accessories", page 51](#)

7 Commissioning

7.1 Teach-in

7.1.1 Teaching in the first actuator

Overview

An actuator must be taught-in during commissioning. Only the most recently taught-in actuator is valid.

During a teach-in operation, the OSSDs are in the OFF state, i.e. the system is in a safe state.

Important information



NOTE

In the delivery state, there is a time window of 30 minutes for teach-in after the device is switched on. The safety locking device then switches to the safe state. For a new time window, the device must be restarted (disconnect voltage supply and redo).



NOTE

The teach-in process is invalid if canceled, e.g. by interruption of the voltage supply or premature removal of the actuator.

The safety locking device then goes into the safe state, and the LEDs indicate the cause of the invalid teach-in process (see "[Fault indications during operation](#)", page 38). The teach-in operation must then be repeated after restarting the device.



NOTE

The taught-in actuator must be documented.

Prerequisites

- Device variant is not universally coded. Universally coded devices do not require a teach-in.

Procedure





1. Open movable physical guard.
2. Connect safety switch to voltage supply (see "[Electrical installation](#)", page 27).
- ✓ The start sequence is executed. All LEDs flash with alternating colors. OSSDs are switched off in the meantime.
- ✓ The following indicators signal that the safety switch is ready for the teach-in sequence.

Table 6: Display before teach-in

STATE LED (red/green)	LOCK LED (yellow/green)	DIAG LED (red/yellow)	Step
● Red	○	●● Red/yellow (4 Hz)	Safety switch ready for teach-in sequence

3. Close movable physical guard.
- ✓ When the movable physical guard is closed and the actuator has reached the required position, the safety switch automatically starts the teach-in sequence after 3 seconds. The individual steps are indicated via the LEDs.

Table 7: Displays of the teach-in sequences

STATE LED (red/green)	LOCK LED (yellow/green)	DIAG LED (red/yellow)	Step
 Green (4 Hz)	○	 Red/yellow (4 Hz)	Actuator is being taught-in
 Green (4 Hz)	○	 Yellow (4 Hz)	Actuator was successfully taught-in

4. No later than 5 minutes after successfully teaching in the actuator, disconnect and restore the voltage supply to the safety switch. Otherwise, the device changes to the safe state.
- ✓ The safety locking device is ready for use.

7.1.2 Teaching in replacement actuators

Overview

The safety locking device can only be operated using the actuator that was last taught in.

Important information



NOTE





Safety locking devices with an actuator that has already been taught-in have a teach-in readiness of approx. 5 minutes after being switched on. During this time window, the following applies:

- If the currently valid actuator is detected, then the teach-in process is canceled. The safety switch goes into normal operation.
- If a deactivated actuator is detected, then the actuator is ignored and the previous actuator remains valid. The teach-in time window remains active, however. The teach-in process starts as soon as a new actuator is detected.
- The device saves the last three deactivated codes only. Actuators that were taught-in at an earlier time can be taught-in again.
- The teach-in process is invalid if canceled, e.g. by interruption of the voltage supply or premature removal of the actuator. The safety locking device then goes into the safe state.

Procedure

1. Open movable physical guard.
 2. Disconnect safety switch from voltage supply for at least 3 seconds.
 3. Connect safety switch to voltage supply (see "Electrical installation", page 27).
- ✓ The start sequence is executed. All LEDs flash with alternating colors. OSSDs are switched off in the meantime.
4. Close movable physical guard.
- ✓ When the movable physical guard is closed and the actuator has reached the required position, the safety switch automatically starts the teach-in sequence. The individual steps are indicated via the LEDs.

Table 8: Displays of the teach-in sequences

STATE LED (red/green)	LOCK LED (yellow/green)	DIAG LED (red/yellow)	Step
 Green (4 Hz)	○	 Red/yellow (4 Hz)	Actuator is being taught-in
 Green (4 Hz)	○	 Yellow (4 Hz)	Actuator was successfully taught-in

5. No later than 5 minutes after successfully teaching in the actuator, disconnect and restore the voltage supply to the safety switch. Otherwise, the device changes to the safe state. The previous actuator remains valid.
- ✓ When the taught-in actuator is in the response range, both OSSDs switch to the ON state and the STATE LED lights up green.

Further topics

- ["Indications when teaching in an actuator", page 37](#)
- ["Fault indications during operation", page 38](#)

7.2 Thorough check during commissioning and modifications



DANGER

Hazard due to unexpected starting of the machine

Death or severe injury

- ▶ Before carrying out the functional test, make sure that there are no people in the hazardous area.
-

Procedure

After installation and after every error, check that the device is functioning correctly. Proceed as follows to do so:

Mechanical function check-out

- ▶ Open the movable physical guard and close it again. The components of the safety locking device must not collide with other parts while doing so. When the movable physical guard is closed, the actuator must be in a position that allows the locking device to actuate.

Electrical function check-out

1. Switch on the supply voltage.
2. Close all movable physical guards and activate the locking function. The machine must not start independently.
3. Check the locking device. The movable physical guard must not be able to be opened.
4. Start the machine function.
5. For variants with locking monitoring (protection of people): Ensure that the locking function cannot be deactivated as long as the dangerous machine function is active.
6. Stop the machine function and deactivate the locking function.
7. Check whether the movable physical guard remains locked until no risk of injury is present anymore (e.g. due to overrun movements).
8. For variants with locking monitoring only (protection of people): check the restart interlock. It must not be possible to start the machine function as long as the locking function is deactivated.
9. For variants with escape release: Check the function of the escape release.
10. Repeat steps [figure X](#) to [figure X](#) for each safety locking device.

Complementary information



NOTE

You can simulate an active lock command by applying the relevant voltage to the "Locking function input" contact.

- Power to lock variant: 24 V DC
 - Power to release variant: 0 V DC
-

8 Operation

8.1 Actuating the auxiliary release

Prerequisites

- TX10 hexalobular wrench
- 4 mm hexalobular wrench

Procedure

1. Ensure that the actuator is not under strong tensile stress (≤ 20 N).
2. Loosen the retaining screw with the screwdriver.
3. Use the hex key to rotate the auxiliary release in the direction of the arrow to the following symbol:



- ✓ The locking function is deactivated.

Complementary information

If a valid actuator is detected and the locking signal is active, the safety locking device will repeatedly attempt to lock itself. If the locking function cannot be activated within the next 10 minutes, the safety locking device changes to the safe state.

8.1.1 Moving the mechanical unlocking mechanism back after use

Procedure

- ▶ Turn the auxiliary release back to the following symbol:
- 
- ▶ Screw in the retaining screw and seal it (e.g. with locking varnish)
 - ▶ Open the movable physical guard and close it again.
 - ✓ The safety locking device operates in normal mode again.
 - ▶ Carry out a functional test.

8.2 Actuating the escape release

Procedure

1. Press the red button of the escape release as far as it goes.
- ✓ The locking function is deactivated.

8.2.1 Moving the escape release back after use

Procedure

- ▶ Pull the red button of the escape release back out.
- ▶ Open the movable physical guard and close it again.
- ✓ The safety locking device operates in normal mode again.
- ▶ Carry out a functional check-out.

8.3 Preventing unintentional closing of the movable physical guard

Overview

For some maintenance work, it is necessary to prevent the movable physical guard from being closing. This can, for example, prevent an unintended restart of the machine.

Prerequisites

- Manual locking mechanism, e.g., padlock or locking pliers. The shackle of the locking mechanism must have a diameter no greater than 9 mm.

Procedure

- ▶ Insert the locking mechanism in the tongue of the actuator and close it.
- ✓ The movable physical guard can no longer be closed.

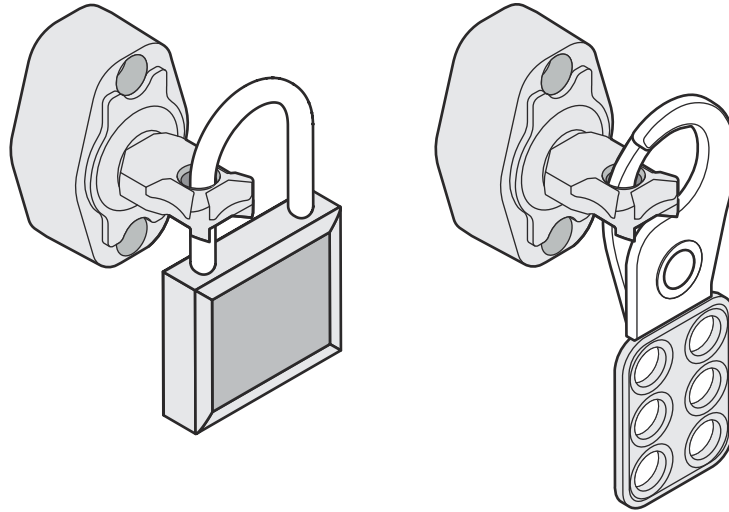

Figure 17: Preventing closing with a lock.

9 Maintenance

9.1 Cleaning

**NOTICE**

- ▶ Do not use aggressive cleaning agents (e.g. isopropanol, methylated spirits or peroxides).
 - ▶ Do not use any substances that hinder the wetting properties of lacquers.
 - ▶ We recommend anti-static cleaning agents.
-

9.2 Regular thorough check

The safety switch must be checked regularly. The type and frequency of thorough checks is defined by the machine manufacturer and operating entity.

The regular thorough checks serve to investigate the effectiveness of the safety switch and detect any ineffectiveness due to modifications or external influences (e.g., damage or manipulation).

- ▶ Carry out the checks specified in the test plan of the manufacturer of the machine and the operating entity.

10 Troubleshooting

10.1 LED displays

Overview

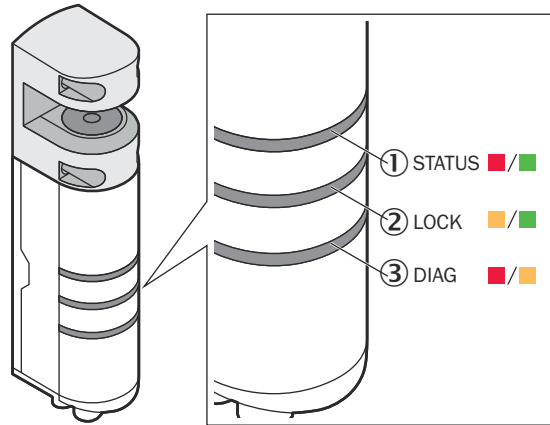

In combination, these LEDs indicate detailed status and error states.

Important information



DANGER

Hazard due to lack of effectiveness of the protective device

Persons and parts of the body to be protected may not be recognized in case of non-observance.

- ▶ Immediately shut the machine down if the behavior of the machine cannot be clearly identified.
- ▶ Immediately put the machine out of operation if you cannot clearly identify or allocate the error and if you cannot safely remedy the error.
- ▶ Secure the machine so that it cannot switch on unintentionally.

LED displays

In general, the STATUS and LOCK LEDs indicate the following states.

Table 9: ① STATUS LED

Display	Status
🟡 Green	Valid actuator detected. OSSD LOW.
🟢 Green	Valid actuator detected. OSSD HIGH.
🔴 Red	No valid actuator detected. OSSD LOW.

Table 10: ② LOCK LED

Display	Status
○	No active locking signal
🟡 Green	Locking signal active, locking function deactivated.
🟢 Green	Locking signal active, locking function activated.
🟡 Yellow	Error when closing or opening.

Table 11: ③ DIAG LED

Display	Status
● Yellow	No valid signal at IN 1 and IN 2
● Red ● Yellow ● Yellow	Meaning depends on what the other LEDs are displaying.
● Red ● Yellow ● Red ● Yellow	

Further topics

- ["Indications when teaching in an actuator", page 37](#)
- ["Status indications during operation", page 37](#)
- ["Fault indications during operation", page 38](#)

10.1.1 Indications when teaching in an actuator

Table 12: Status indications during teach-in

LED indicators			OSSDs	Inputs		Status
STATUS	LOCK	DIAG		LOCK	IN 1/IN 2	
● Red ● Green (2 Hz)	● Yellow ● Green (2 Hz)	● Red ● Yellow (2 Hz)	OFF	Not relevant	Not relevant	Device is being switched on and is performing a self-diagnostic test.
● Red	○	● Red ● Yellow (4 Hz)	OFF	Not relevant	Not relevant	In the delivery state: No actuator detected. You can start the teach-in.
● Green (4 Hz)	○	● Red ● Yellow (4 Hz)	OFF	Not relevant	Not relevant	Device is teaching in the actuator.
● Green (4 Hz)	○	● Yellow (4 Hz)	OFF	Not relevant	Not relevant	Actuator was successfully taught-in. To complete the teach-in process, disconnect and restore the voltage supply.

Table 13: Error indications during teach-in

LED indicators			OSSDs	Inputs		Cause	Troubleshooting
STATUS	LOCK	DIAG		LOCK	IN 1/IN 2		
● Red ● Green (4 Hz)	○	● Red (4 Hz)	OFF	Not relevant	Not relevant	Teach-in failed. Device was not restarted within the expected time	Disconnect and restore the voltage supply. Repeat the teach-in.
● Red ● Green (4 Hz)	○	● Red	OFF	Not relevant	Not relevant	Teach-in failed. Actuator was removed too soon.	Disconnect and restore the voltage supply. Repeat the teach-in.
● Red	Not relevant	● Yellow (1 Hz)	OFF	Not relevant	Not relevant	Actuator was used previously and is invalid.	Use a valid actuator.

10.1.2 Status indications during operation

Table 14: Status indications during operation

LED indicators			OSSDs	Inputs		Status
STATUS	LOCK	DIAG		LOCK	IN 1/IN 2	
● Red	● Green (1 Hz)	Not relevant	OFF	Lock requested.	Not relevant	No actuator detected.
● Red	○	Not relevant	OFF	Unlock requested.	Not relevant	No actuator detected.

LED indicators			OSSDs	Inputs		Status
STATUS	LOCK	DIAG		LOCK	IN 1/IN 2	
Green (1 Hz)	○	Yellow	OFF	Unlock requested.	OFF	Actuator detected. Locking function is deactivated. No valid enable signal at IN1 and IN2
Green (1 Hz)	Green	Yellow	OFF	Lock requested.	OFF	Actuator detected. Locking function is activated. No valid enable signal at IN1 and IN2
Green (1 Hz)	○	○	OFF	Unlock requested.	ON	Actuator detected. Locking function is deactivated.
Green	Green	○	ON	Lock requested.	ON	Actuator detected. Locking function is activated.
Green	○	○	ON	Unlock requested.	ON	Actuator detected. Locking function is deactivated.
Not relevant	Not relevant	Yellow	OFF	Not relevant	OFF	No valid enable signal at IN1 and IN2
Not relevant	Not relevant	Red (1 Hz)	Not relevant	Not relevant	Not relevant	Supply voltage too low or too high

10.1.3 Fault indications during operation

Table 15: Fault indications during operation

LED displays			OSSDs	Inputs		Cause	Troubleshooting
STATUS	LOCK	DIAG		LOCK	IN 1/IN 2		
Red (1 Hz)	Yellow	Red (1 Hz)	OFF	Not relevant	Not relevant	Device has tried unsuccessfully to activate or deactivate the safety locking function for 10 minutes.	<ul style="list-style-type: none"> ▶ Make sure that the auxiliary release is not active. ▶ Make sure that the escape release is not active. ▶ Check the alignment of the actuator. ▶ Check that the actuator reaches the end position when closing the door. ▶ Check whether the locking pin is blocked by foreign bodies.
Red (1 Hz)	○	Red (4 Hz)	OFF	Not relevant	Not relevant	External error	<ul style="list-style-type: none"> ▶ Check the OSSD connection for a cross-circuit or short-circuit. ▶ Check the cables for damage. ▶ Disconnect and restore the voltage supply.
Red (1 Hz)	○	Red (1 Hz)	OFF	Not relevant	Not relevant	Supply voltage too low or too high	<ol style="list-style-type: none"> 1. Check the supply voltage. 2. Disconnect and restore the voltage supply.

LED displays			OSSDs	Inputs		Cause	Troubleshooting
STATUS	LOCK	DIAG		LOCK	IN 1/IN 2		
● Red	☀ Yellow (1 Hz)	● Red	OFF	Lock requested.	Not relevant	<ul style="list-style-type: none"> ▶ Actuator was removed while the locking function was active. Actuator is probably damaged. ▶ The actuator was removed immediately after activation/deactivation of the locking function and before the locking bolt could reach the end position. ▶ EMC fault 	<ul style="list-style-type: none"> ▶ For a mechanically damaged actuator: Replace actuator. ▶ Prevent simultaneous activation/deactivation of the locking function and opening of the door. ▶ Check the application for EMC interference sources. Contact SICK.
● Green (1 Hz) or ● Green	☀● Yellow/green (1 Hz)	Irrelevant	Not relevant	Lock requested.	Not relevant	Unable to activate the safety locking function	Check the alignment of the actuator. Check whether the movable physical guard is pulling on the actuator.
● Green (1 Hz) or ● Green	☀● Yellow/green (4 Hz)	Irrelevant	Not relevant	Unlock requested.	Not relevant	Unable to deactivate the safety locking function.	Check the alignment of the actuator. Check whether the movable physical guard is pulling on the actuator.
○	○	● Red	OFF	Not relevant	Not relevant	Internal error	<ul style="list-style-type: none"> ▶ Ensure that the device is not being used contrary to its intended use. see "Improper use", page 8 ▶ If problem persists, replace device.
Irrelevant	Irrelevant	●● Red/yellow (1 Hz)	Not relevant	Not relevant	Not relevant	Application diagnostic output error	<ul style="list-style-type: none"> ▶ Check application diagnostic output cable for short-circuit to 0 V. ▶ Check cable for damage.

11 Decommissioning

11.1 Disposal

Procedure

- ▶ Always dispose of unusable devices in accordance with national waste disposal regulations.



Complementary information

SICK will be glad to help you dispose of these devices on request.

12 Technical data

12.1 Data sheet

Table 16: Features

Principle of operation	RFID
Actuating force	20 N
Retaining force	30 N
Force against which unlocking is possible	≤ 25 N
Actuator frequency (detection of the actuator)	≤ 1 Hz
Actuation speed of the actuator	≤ 20 m/min
Dwell time between unlocking and locking	1.5 s

Table 17: Locking forces

Locking force F_{Zh} ($F_{Zh} = F_{max} / 1.3$)	
Flexible actuator	3,150 N (EN ISO 14119)
Rigid actuator (frontal)	2,790 N (EN ISO 14119)
Rigid actuator (lateral)	2,700 N (EN ISO 14119)
Locking force F for fault exclusion ($F = F_{max} / 2$) ¹⁾	
Flexible actuator	2,050 N (EN ISO 14119)
Rigid actuator (frontal)	1,815 N (EN ISO 14119)
Rigid actuator (lateral)	1,755 N (EN ISO 14119)

1) Use these values if the locking function requires performance level PL e or for applications with a long stopping/run-down time.

Table 18: Safety-related parameters

Safety integrity level <ul style="list-style-type: none"> Monitoring of the position of the protective device (interlocking monitoring) Locking monitoring 	SIL3 (IEC 61508)
Safety integrity level <ul style="list-style-type: none"> Locking function 	SIL2 (IEC 61508)
Category <ul style="list-style-type: none"> Monitoring of the position of the protective device (interlocking monitoring) Locking monitoring 	Category 4 (ISO 13849-1)
Category <ul style="list-style-type: none"> Locking function 	Category 2 (ISO 13849-1)
Performance level <ul style="list-style-type: none"> Monitoring of the position of the protective device (interlocking monitoring) Locking monitoring 	PL e (ISO 13849-1)
Performance level <ul style="list-style-type: none"> Locking function 	PL d ¹⁾ (ISO 13849-1)
PFH _D (mean probability of a dangerous failure per hour)	9.55 × 10 ⁻⁹ at 40 °C and 0 m above sea level 1.06 × 10 ⁻⁸ at 40 °C and 2,000 m above sea level
T _M (mission time)	20 years (ISO 13849-1)

Type	Type 4 (ISO 14119)
Coding	
FXL1-SPxUxA00	Uniquely coded (high coding level according to ISO 14119)
FXL1-SPxMxA00	Universally coded (low coding level according to ISO 14119)
Safe status when an error occurs	At least one safety-related semiconductor output (OSSD) is in the OFF state.

1) With fault exclusion (e.g., according to EN ISO 13849-2) up to PLe

Table 19: Electrical data

Classification based on cULus	Class 2
Protection class	III (IEC 61140)
Utilization category	DC 12: 24 V / 100 mA (IEC 60947-5-2)
Supply voltage U_V	24 V DC (19.2 V DC ... 28.8 V DC) (SELV/PELV)
Current consumption at 24 V DC voltage supply (without load)	
FXL1-SPB***** / FXL1-SPE*****	65 mA
FXL1-SPL***** / FXL1-SPU*****, locking function deactivated	65 mA
FXL1-SPL***** / FXL1-SPU*****, locking function activated	125 mA
Peak current consumption at 24 V (without load)	800 mA for max. 200 ms
Degree of contamination	3 (IEC 60947-1)
Rated insulation voltage U_i	32 V (IEC 60947-1)
Rated impulse withstand voltage U_{imp}	1,500 V (IEC 60947-5-1)
Power-up time	3 s
Bridging time in case of power outage	FXL1-SPB*****: ≤ 4 ms FXL1-SPE*****: ≤ 4 ms FXL1-SPL*****: ≤ 2 ms FXL1-SPU*****: ≤ 2 ms
Response time (time to reach the OFF state of the OSSDs)	≤ 150 ms ¹⁾
Enable time (time to reach the ON state of the OSSDs)	≤ 350 ms ¹⁾²⁾
Risk time ³⁾	150 ms ¹⁾

1) In safe series connection: +70 ms for each additional device

2) If the actuator is removed by opening the door immediately after activating the locking device and before the ON state of the OSSD is reached, the switch goes into the error state.

3) The risk time is the time needed to detect internal and external faults. External errors affect the OSSDs (short-circuit to an OSSD and cross-circuit between the two OSSDs). At least one of the two OSSDs is safely switched off during the risk time.

Table 20: Interfaces

System connection	Male connector, M12, 8-pin, A-coded (common male connector for voltage supply and outputs)
-------------------	--

Table 21: Inputs

Input voltage for ON state (HIGH)	24 V (15 V DC ... 28.8 V DC)
Input voltage for OFF state (LOW)	≤ 2 V DC
Input current for ON state (HIGH)	≤ 5 mA
Input current for OFF state (LOW)	≤ 500 μ A

Table 22: Safety outputs (OSSDs)

Type of output	2 PNP semiconductors, short-circuit protected, cross-circuit monitored
Output current	
ON state	≤ 100 mA
OFF state	≤ 500 µA
Output voltage	
ON state	U _V -2 V DC ... U _V (max. voltage drop ≤ 2 V DC)
OFF state	≤ 2 V DC
Capacitive load	≤ 400 nF
Test pulse width	≤ 300 µs
Test pulse interval	Typically 40 ms ±5 ms

Table 23: Application diagnostic output

Output current	≤ 50 mA
Output voltage in OFF state	≤ 2 V DC
Output voltage in ON state	U _v - 2 V DC ... U _v (max. voltage drop ≤ 2 V DC)

Table 24: Mechanical data

Dimensions (W x H x D)	see "Safety switch dimensional drawings", page 44 see "Actuator dimensional drawings", page 47 see "Dimensional drawings of the mounting bracket", page 48
Material	
Safety switch housing	Vistal® (fiberglass-reinforced thermoplastic)
Retaining ball	Stainless steel
Actuator tongue	Stainless steel
Plug connector	Stainless steel
Weight	
Power to release safety switch	480 g
Power to lock safety switch	535 g
Flexible actuator	90 g
Rigid actuator	75 g
Mechanical service life	1 × 10 ⁶ switching operations

Table 25: Ambient data

Enclosure rating	IP65 (IEC 60529) IP67 (IEC 60529) IP69K (IEC 20653)
Ambient operating temperature	-20 °C ... +55 °C
Storage temperature	-25 °C ... +70 °C
Relative humidity	10 - 95% at 40 °C (IEC 60068)
Vibration resistance	1 mm / 10 Hz ... 55 Hz (IEC 60068-2-6)
Shock resistance	30 g, 11 ms (EN 60068-2-27)
EMC	In accordance with IEC/EN 61326-3-1, IEC/EN 60947-5-2, IEC/EN 60947-5-3 and EN 300330

12.2 Classification according to ZVEI, CB24I

Table 26: Enable inputs for OSSDs (In1, In2)

Sink (this device)	C0
Compatible source	C2, C3

Table 27: Output OSSDs (OSSD1, OSSD2)

Source (this device)	C2
Compatible sink	C1, C2

Table 28: Application diagnostic output (Out AUX)

Source (this device)	C0
Compatible sink	C1, C2, C3

12.3 Connecting cables

Requirements for the connecting cables

Recommended cable type = LIYY 8 x 0.25 mm² or 5 x 0.34 mm²

12.4 Safety switch dimensional drawings

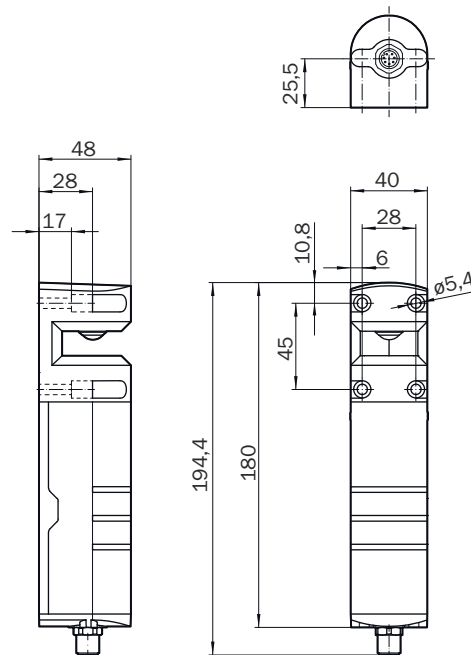

Figure 18: Safety switch dimensional drawings

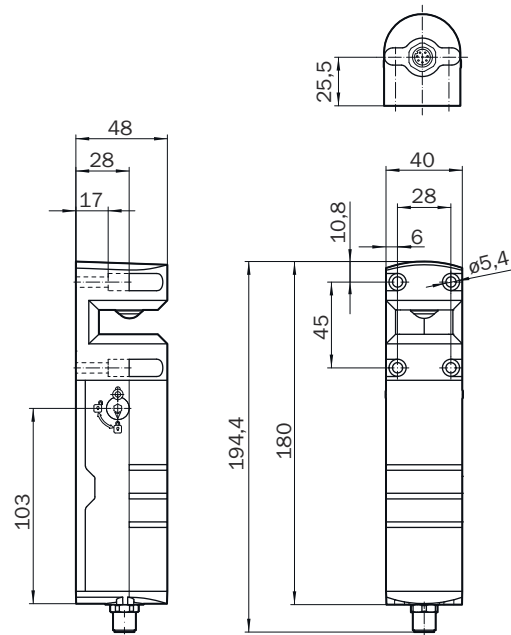

Figure 19: Safety switch with auxiliary release dimensional drawings

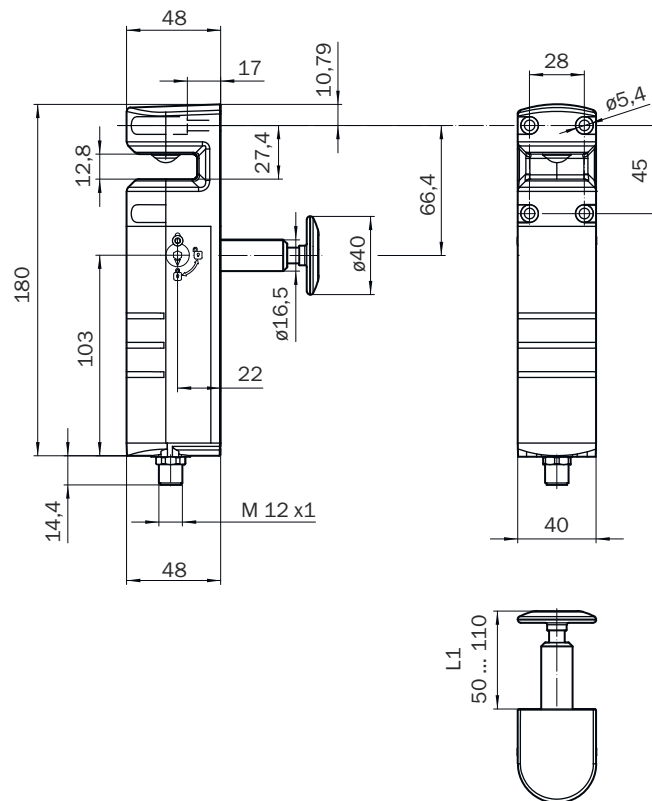

Figure 20: Dimensional drawings for safety switch with auxiliary release, with escape release

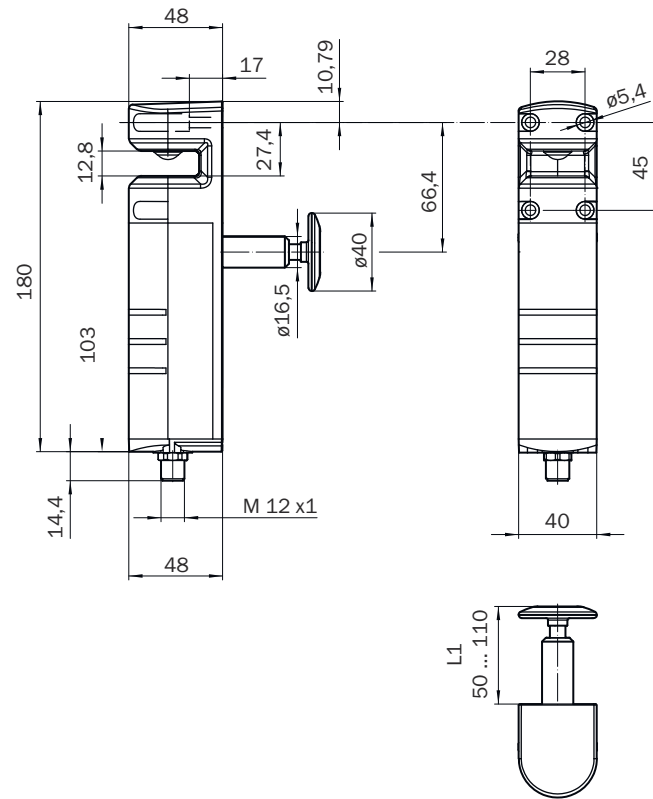

Figure 21: Dimensional drawings for safety switch without auxiliary release, with escape release

Number of extension pieces	L1
0	50
1	80
2	110

12.5 Actuator dimensional drawings

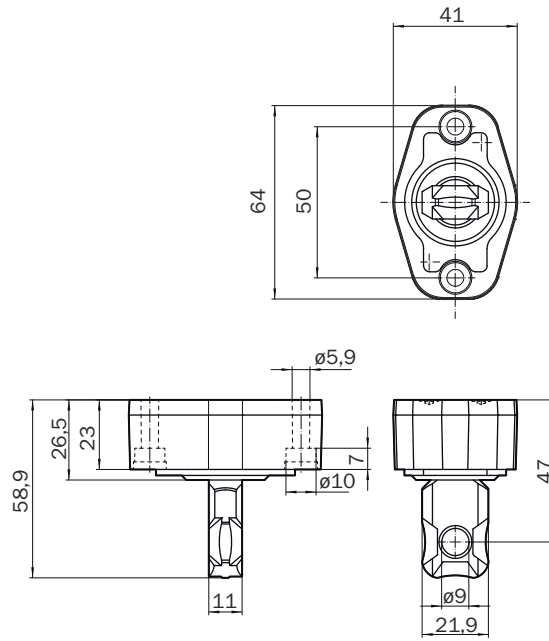

Figure 22: Flexible actuators dimensional drawings

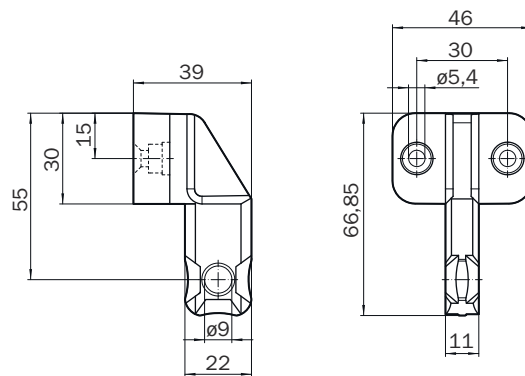

Figure 23: Rigid actuators dimensional drawings

12.6 Dimensional drawings of the mounting bracket

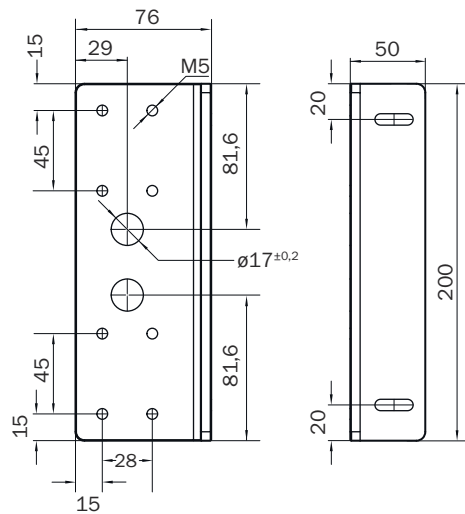

Figure 24: Dimensional drawing for FXL1-XMS1 mounting bracket for safety locking device

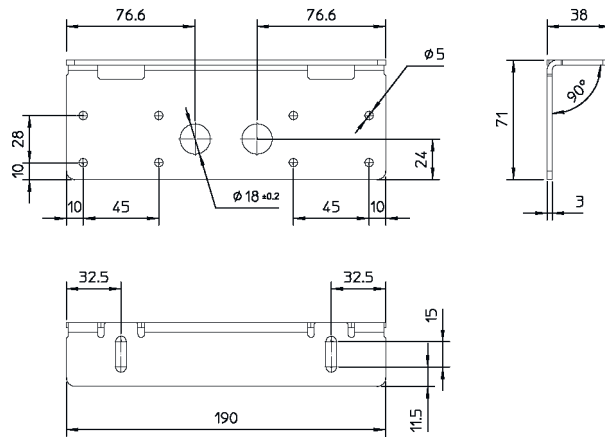

Figure 25: Dimensional drawing for FXL1-XMS3 mounting bracket for safety locking device

12.7 Dimensional drawings for extension pieces

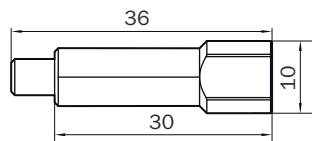

Figure 26: Dimensional drawing for extension piece

12.8 Dimensional drawings for adapter plates

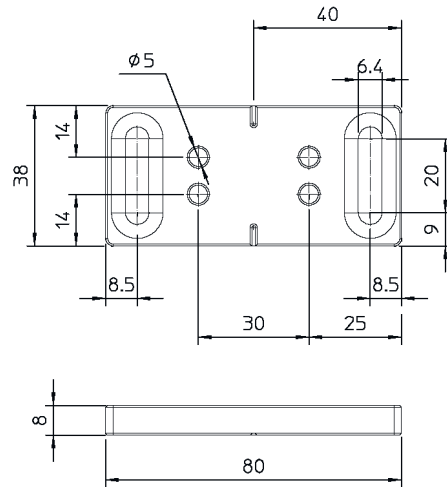

Figure 27: Dimensional drawing for FXL1-XMA1 adapter plate for actuator

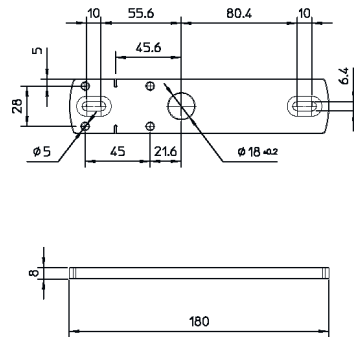

Figure 28: Dimensional drawing for FXL1-XMS2 adapter plate for safety locking device

13 Ordering information

13.1 Scope of delivery

- safety switch
- 4 x blind plugs for secure mounting
- Safety note
- 2 x extension pieces for escape release (for variants with escape release only)
- Operating instructions for download: www.sick.com

13.2 Ordering information

Table 29: Ordering information for power to release safety locking devices

Switching behavior of the OSSDs	Coding	Unlocking options	Type code	Part number
Locking monitoring	Uniquely coded	<ul style="list-style-type: none"> • Auxiliary release 	FXL1-SPBUSA00	1101320
Locking monitoring	Universally coded	<ul style="list-style-type: none"> • Auxiliary release 	FXL1-SPBMSA00	1101321
Locking monitoring	Uniquely coded	<ul style="list-style-type: none"> • Auxiliary release • Escape release 	FXL1-SPEUSA00	1120827
Locking monitoring	Universally coded	<ul style="list-style-type: none"> • Auxiliary release • Escape release 	FXL1-SPEMSA00	1120828

Table 30: Ordering information for power to lock safety locking devices

Switching behavior of the OSSDs	Coding	Unlocking options	Type code	Part number
Locking monitoring	Uniquely coded	–	FXL1-SPLUSA00	1101322
Locking monitoring	Universally coded	–	FXL1-SPLMSA00	1101323
actuator monitoring	Uniquely coded	–	FXL1-SPLUAA00	1101324
actuator monitoring	Universally coded	–	FXL1-SPLMAA00	1101325
Locking monitoring	Uniquely coded	<ul style="list-style-type: none"> • Escape release 	FXL1-SPUUSA00	1122586
Locking monitoring	Universally coded	<ul style="list-style-type: none"> • Escape release 	FXL1-SPUMSA00	1122587

14 Accessories

14.1 Actuator

Table 31: Actuator flexLock

Description	Type code	Part number
Actuator, flexible	FXL1-AF1	1101326
Actuator, rigid	FXL1-AR1	1101327

14.2 Connection technology

Connecting cable, M12, 8-pin (0.25 mm²)

Table 32: Ordering information for connection cable, M12, 8-pin (0.25 mm²) ¹⁾

Part	Type code	Part number
Female connector, straight, 2 m cable, flying leads	YF2A18-020UA5XLEAX	2095652
Female connector, straight, 2.5 m cable, flying leads	YF2A18-025UA5XLEAX	2099229
Female connector, straight, 5 m cable, flying leads	YF2A18-050UA5XLEAX	2095653
Female connector, straight, 7.5 m cable, flying leads	YF2A18-075UA5XLEAX	2099230
Female connector, straight, 10 m cable, flying leads	YF2A18-100UA5XLEAX	2095654
Female connector, straight, 15 m cable, flying leads	YF2A18-150UA5XLEAX	2095679
Female connector, straight, 20 m cable, flying leads	YF2A18-200UA5XLEAX	2095680
Female connector, straight, 30 m cable, flying leads	YF2A18-300UA5XLEAX	2095681
Female connector, angled, 2 m cable, flying leads	YG2A18-020UA5XLEAX	2095779
Female connector, angled, 5 m cable, flying leads	YG2A18-050UA5XLEAX	2095780
Female connector, angled, 10 m cable, flying leads	YG2A18-100UA5XLEAX	2095781

1) Ambient operating temperature: down to -30 °C with fixed installation.

Connection cable, M12, 5-pin (0.34 mm²)

Table 33: Ordering information for M12 connection cable, 5-pin (0.34 mm²) ²⁾

Part	Type code	Part number
Female connector, straight, 0.6 m cable, male connector, straight	YF2A15-C60UB5M2A15	2096006
Female connector, straight, 1 m cable, male connector, straight	YF2A15-010UB5M2A15	2096007
Female connector, straight, 2 m cable, male connector, straight	YF2A15-020UB5M2A15	2096009
Female connector, straight, 5 m cable, male connector, straight	YF2A15-050UB5M2A15	2096010
Female connector, straight, 10 m cable, male connector, straight	YF2A15-100UB5M2A15	2096011
Female connector, straight, 15 m cable, male connector, straight	YF2A15-150UB5M2A15	2096171

Connection cable, M12, 8-pin (0.25 mm²)

Table 34: Ordering information for M12 connection cable, 8-pin (0.25 mm²) ²⁾

Part	Type code	Part number
Female connector, straight, 0.6 m cable, straight male connector	YF2A18-C60UA5M2A18	2096031
Female connector, straight, 1 m cable, straight male connector	YF2A18-010UA5M2A18	2096032
Female connector, straight, 20 m cable, straight male connector	YF2A18-020UA5M2A18	2096033
Female connector, straight, 1 m cable, straight male connector	YF2A18-050UA5M2A18	2096034
Female connector, straight, 10 m cable, straight male connector	YF2A18-100UA5M2A18	2096035
Female connector, straight, 15 m cable, straight male connector	YF2A18-150UA5M2A18	2104374

Distribution lists

Table 35: Distributor ordering information

Part	Type code	Part number
T-connector	STR1-XXA	5339609

End connector

Table 36: End connector ordering information

Part	Type code	Part number
End connector for series connection	MLP1-XXT	1078201

²⁾ Ambient operating temperature: Down to -30° C with fixed installation.

14.3 Mounting accessories

Mounting bracket ³⁾

Table 37: Mounting bracket flexLock

Description	Type code	Part number
Mounting bracket for safety locking device, aluminum	FXL1-XMS1	1122229
Mounting bracket for safety locking device, stainless steel	FXL1-XMS3	1139208

- 1) Minimum requirement for mounting screws
- Size: M6
 - Stainless steel screws: A2-70 or higher
 - Tightening torque: 5 Nm

Adapter plate

Table 38: Adapter plate flexLock

Description	Type code	Part number
Adapter plate for safety locking device, aluminum	FXL1-XMS2	1139207
Adapter plate for actuator, aluminum	FXL1-XMA1	1139209

Extension piece for escape release

Table 39: Extension piece for escape release flexLock

Description	Type code	Part number
2 × extension piece Two extension pieces (30 mm each) for the axis of the escape release	-	2132721

3) 1

15 Annex

15.1 Conformities and certificates

You can obtain declarations of conformity, certificates and the current documentation for the product at www.sick.com. To do so, enter the product part number in the search field (part number: see the entry in the “P/N” or “Ident. no.” field on the type label).

15.1.1 EU declaration of conformity

Excerpt

The undersigned, representing the manufacturer, herewith declares that the product is in conformity with the provisions of the following EU directive(s) (including all applicable amendments), and that the standards and/or technical specifications stated in the EU declaration of conformity have been used as a basis for this.

- ROHS DIRECTIVE 2011/65/EU
- MACHINERY DIRECTIVE 2006/42/EC
- RE DIRECTIVE 2014/53/EU

15.1.2 UK declaration of conformity

Excerpt

The undersigned, representing the following manufacturer herewith declares that this declaration of conformity is issued under the sole responsibility of the manufacturer. The product of this declaration is in conformity with the provisions of the following relevant UK Statutory Instruments (including all applicable amendments), and the respective standards and/or technical specifications have been used as a basis.

- Restriction of the Use of Certain Hazardous Substances in Electrical and Electronic Equipment Regulations 2012
- Supply of Machinery (Safety) Regulations 2008
- Radio Equipment Regulations 2017

15.1.3 FCC and IC radio approval

- FCC ID: 2AHDRFXL1
- IC: 21147FXL1

The device fulfills the EMC requirements for use in the USA and Canada, in accordance with the following extracts from the relevant approvals:

FCC § 15.19

This device complies with Part 15 of the FCC rules. Operation is subject to the following two conditions:

- This device may not cause harmful interference, and
- this device must accept any interference received, including interference that may cause undesired operation.

FCC §15.21 (warning statement)

[Any] changes or modifications not expressly approved by the party responsible for compliance could void the user's authority to operate the equipment.

IC

This device complies with Industry Canada's licence-exempt RSSs. Operation is subject to the following two conditions:

- This device may not cause interference; and
- This device must accept any interference, including interference that may cause undesired operation of the device.

Le présent appareil est conforme aux CNR d'Industrie Canada applicables aux appareils radio exempts de licence. L'exploitation est autorisée aux deux conditions suivantes :

- l'appareil ne doit pas produire de brouillage;
- l'utilisateur de l'appareil doit accepter tout brouillage radioélectrique subi, même si le brouillage est susceptible d'en compromettre le fonctionnement.

Australia
Phone +61 (3) 9457 0600
1800 33 48 02 – tollfree
E-Mail sales@sick.com.au

Austria
Phone +43 (0) 2236 62288-0
E-Mail office@sick.at

Belgium/Luxembourg
Phone +32 (0) 2 466 55 66
E-Mail info@sick.be

Brazil
Phone +55 11 3215-4900
E-Mail comercial@sick.com.br

Canada
Phone +1 905.771.1444
E-Mail cs.canada@sick.com

Czech Republic
Phone +420 234 719 500
E-Mail sick@sick.cz

Chile
Phone +56 (2) 2274 7430
E-Mail chile@sick.com

China
Phone +86 20 2882 3600
E-Mail info.china@sick.net.cn

Denmark
Phone +45 45 82 64 00
E-Mail sick@sick.dk

Finland
Phone +358-9-25 15 800
E-Mail sick@sick.fi

France
Phone +33 1 64 62 35 00
E-Mail info@sick.fr

Germany
Phone +49 (0) 2 11 53 010
E-Mail info@sick.de

Greece
Phone +30 210 6825100
E-Mail office@sick.com.gr

Hong Kong
Phone +852 2153 6300
E-Mail ghk@sick.com.hk

Hungary
Phone +36 1 371 2680
E-Mail erteakesites@sick.hu

India
Phone +91-22-6119 8900
E-Mail info@sick-india.com

Israel
Phone +972 97110 11
E-Mail info@sick-sensors.com

Italy
Phone +39 02 27 43 41
E-Mail info@sick.it

Japan
Phone +81 3 5309 2112
E-Mail support@sick.jp

Malaysia
Phone +603-8080 7425
E-Mail enquiry.my@sick.com

Mexico
Phone +52 (472) 748 9451
E-Mail mexico@sick.com

Netherlands
Phone +31 (0) 30 204 40 00
E-Mail info@sick.nl

New Zealand
Phone +64 9 415 0459
0800 222 278 – tollfree
E-Mail sales@sick.co.nz

Norway
Phone +47 67 81 50 00
E-Mail sick@sick.no

Poland
Phone +48 22 539 41 00
E-Mail info@sick.pl

Romania
Phone +40 356-17 11 20
E-Mail office@sick.ro

Singapore
Phone +65 6744 3732
E-Mail sales.gsg@sick.com

Slovakia
Phone +421 482 901 201
E-Mail mail@sick-sk.sk

Slovenia
Phone +386 591 78849
E-Mail office@sick.si

South Africa
Phone +27 10 060 0550
E-Mail info@sickautomation.co.za

South Korea
Phone +82 2 786 6321/4
E-Mail infokorea@sick.com

Spain
Phone +34 93 480 31 00
E-Mail info@sick.es

Sweden
Phone +46 10 110 10 00
E-Mail info@sick.se

Switzerland
Phone +41 41 619 29 39
E-Mail contact@sick.ch

Taiwan
Phone +886-2-2375-6288
E-Mail sales@sick.com.tw

Thailand
Phone +66 2 645 0009
E-Mail marcom.th@sick.com

Turkey
Phone +90 (216) 528 50 00
E-Mail info@sick.com.tr

United Arab Emirates
Phone +971 (0) 4 88 65 878
E-Mail contact@sick.ae

United Kingdom
Phone +44 (0)17278 31121
E-Mail info@sick.co.uk

USA
Phone +1 800.325.7425
E-Mail info@sick.com

Vietnam
Phone +65 6744 3732
E-Mail sales.gsg@sick.com

Detailed addresses and further locations at www.sick.com