

# i14 Lock

Safety locking device

**SICK**  
Sensor Intelligence.



---

**Described product**

i14 Lock

**Manufacturer**

SICK AG  
Erwin-Sick-Str. 1  
79183 Waldkirch  
Germany

**Legal information**

This work is protected by copyright. Any rights derived from the copyright shall be reserved for SICK AG. Reproduction of this document or parts of this document is only permissible within the limits of the legal determination of Copyright Law. Any modification, abridgment or translation of this document is prohibited without the express written permission of SICK AG.

The trademarks stated in this document are the property of their respective owner.

© SICK AG. All rights reserved.

**Original document**

This document is an original document of SICK AG.



## Contents

<b>1</b>	<b>About this document.....</b>	<b>5</b>
1.1	Scope.....	5
1.2	Additional information.....	5
1.3	Symbols and document conventions.....	5
<b>2</b>	<b>Safety information.....</b>	<b>7</b>
2.1	General safety notes.....	7
2.2	Intended use.....	7
2.3	Requirements for the qualification of personnel.....	7
<b>3</b>	<b>Product description.....</b>	<b>8</b>
3.1	Setup and function.....	8
3.2	Product characteristics.....	8
3.3	Symbols on the product.....	9
3.4	Manual unlocking.....	9
<b>4</b>	<b>Project planning.....</b>	<b>10</b>
4.1	Manufacturer of the machine.....	10
4.2	Operator of the machine.....	10
4.3	Design.....	11
4.4	Integrating into the electrical control.....	11
4.5	Testing plan.....	11
<b>5</b>	<b>Mounting.....</b>	<b>12</b>
5.1	Safety.....	12
5.2	Converting the actuating head.....	12
5.3	Mounting.....	13
5.4	Protection from environmental influences.....	14
<b>6</b>	<b>Electrical installation.....</b>	<b>15</b>
6.1	Safety.....	15
6.2	Pin assignment.....	15
6.3	System connection (cable entry).....	15
<b>7</b>	<b>Commissioning.....</b>	<b>16</b>
7.1	Testing.....	16
7.2	Recurring technical checks.....	16
<b>8</b>	<b>Decommissioning.....</b>	<b>18</b>
8.1	Disposal.....	18
<b>9</b>	<b>Technical data.....</b>	<b>19</b>
9.1	Technical data.....	19
9.2	Dimensional drawings.....	20

<b>10</b>	<b>Ordering information.....</b>	<b>21</b>
10.1	Ordering information.....	21
<b>11</b>	<b>Accessories.....</b>	<b>22</b>
11.1	Actuator.....	22
11.2	Additional accessories.....	22
<b>12</b>	<b>Annex.....</b>	<b>23</b>
12.1	Conformities and certificates.....	23

## 1 About this document

### 1.1 Scope

These operating instructions are valid for all i14 Lock safety locking devices.

This document is included with the following SICK part numbers (this document in all available language versions):

8022225

### 1.2 Additional information

[www.sick.com](http://www.sick.com)

The following information is available on the Internet:

- Data sheets and application examples
- CAD data and dimensional drawings
- Certificates (e.g. EU declaration of conformity)
- Guide for Safe Machinery Six steps to a safe machine

### 1.3 Symbols and document conventions

The following symbols and conventions are used in this document:

#### Safety notes and other notes



#### **DANGER**

Indicates a situation presenting imminent danger, which will lead to death or serious injuries if not prevented.



#### **WARNING**

Indicates a situation presenting possible danger, which may lead to death or serious injuries if not prevented.



#### **CAUTION**

Indicates a situation presenting possible danger, which may lead to moderate or minor injuries if not prevented.



#### **NOTICE**

Indicates a situation presenting possible danger, which may lead to property damage if not prevented.



#### **NOTE**

Indicates useful tips and recommendations.

#### Instructions to action

- ▶ The arrow denotes instructions to action.
  1. The sequence of instructions for action is numbered.
  2. Follow the order in which the numbered instructions are given.
- ✓ The check mark denotes the result of an instruction.

#### LED symbols

These symbols indicate the status of an LED:

## 1 ABOUT THIS DOCUMENT

---

- The LED is off.
- ◐ The LED is flashing.
- The LED is illuminated continuously.

## 2 Safety information

### 2.1 General safety notes

The safety locking device must be configured and operated correctly by qualified safety personnel according to the machine requirements.

### 2.2 Intended use

The safety locking device is a locking unit with a safety locking function and is suitable for the following applications:

- Temporarily preventing access to a hazardous area
- Monitoring of movable physical guards

In conjunction with a movable physical guard and the machine controller, the safety locking device prevents the movable physical guard from being opened. The locking function remains locked for as long as the hazardous machine function is performed or until the production step has finished.

The product may be used in safety functions.

The product is only suitable for use in industrial environments.

Incorrect use, improper modification of or tampering with the safety locking device will invalidate any warranty from SICK AG; in addition, any responsibility and liability of SICK AG for damage and secondary damage caused by this is excluded.

### 2.3 Requirements for the qualification of personnel

The safety locking device must be planned in, installed, connected, commissioned, and serviced only by qualified safety personnel.

#### **Project planning**

You need safety expertise to implement safety functions and select suitable products for that purpose. You need expert knowledge of the applicable standards and regulations.

#### **Mounting, electrical installation and commissioning**

You need suitable expertise and experience. You must be able to assess if the machine is operating safely.

#### **Operation and maintenance**

You need suitable expertise and experience. You must be instructed in machine operation by the machine operator. For maintenance, you must be able to assess if the machine is operating safely.

### 3 Product description

#### 3.1 Setup and function

The safety locking device is an interlocking device consisting of a mechanically-actuated position switch and a coded actuator. The actuator has a lower coding level. The position switch contains a rotating switching cylinder which the actuator grips during closing. The switching cylinder is locked or unlocked electromagnetically (variant-dependent).

When inserting and removing the actuator, switching contacts for door monitoring are opened and closed. When locking and unlocking the locking device, switching contacts for locking device monitoring are opened and closed.

If the locking device is locked, the actuator cannot be removed from the actuating head. The locking device can only be locked when the protective device is closed.

#### 3.2 Product characteristics

##### 3.2.1 Product variants

The safety locking device is delivered in different variants. You will find an overview of important distinguishing features of the variants in the following.

- Type of contacts for locking device monitoring

Complete overview of all variants: [see "Ordering information", page 21](#)

##### Standby current locking principle

###### i14-M

- Locking locking device: close protective device, no voltage on the magnet
- Unlocking locking device: apply voltage to magnet

If voltage is interrupted at the magnet, the locking device remains locked and the protective device cannot be opened immediately.



##### WARNING

The locking device locks even when voltage is not present  
People could get trapped.

- ▶ If people are in the hazardous area, do not close the protective device even voltage is not present.
- 

##### 3.2.2 Locking device monitoring

All variants feature 3 contacts for locking device monitoring. At least 2 contacts are always positive opening normally closed contacts. Depending on the product variant, 1 contact can be a normally open contact. The output state changes when locking or unlocking the locking device.

##### 3.2.3 Status indicators

The safety locking device outputs the status of the locking device using the light emitting diode.







Table 1: Status LEDs

Light emitting diode status	Meaning
●	Voltage is present on the magnet for the locking device. Locking device unlocked.
○	No voltage is present on the magnet for the locking device. Locking device locked with inserted actuator.

### 3.3 Symbols on the product

Table 2: Symbols on the product

Symbol	Meaning
	Positive opening normally closed contact for locking device monitoring
	Positive opening normally closed contact for door monitoring
	Mechanical unlocking mechanism actuated, safety locking device unlocked
	Mechanical unlocking mechanism not actuated, safety locking device functions normally

### 3.4 Manual unlocking

In some situations, it necessary to unlock the locking device manually (e.g. is faults are present). After unlocking, a function test must be performed.

#### Mechanical unlocking mechanism

With the mechanical unlocking mechanism, the safety locking device can be unlocked regardless of the status.

When actuating the mechanical unlocking mechanism, the contacts for locking device monitoring open. A stop command must be generated.

#### Actuating the mechanical unlocking mechanism

- ▶ Ensure tensile stress is not applied on the actuator.
- ▶ Use the screwdriver to rotate the mechanical unlocking mechanism in the direction of the arrow to the following symbol:



- ✓ The locking device is unlocked.



#### WARNING

Permanent actuation of the mechanical unlocking mechanism  
Hazard due to lack of effectiveness of the protective device

- ▶ Put back mechanical unlocking mechanism after use.



### 4 Project planning

#### 4.1 Manufacturer of the machine

---



##### **DANGER**

Failure to comply with manufacturer's obligations

Hazard due to lack of effectiveness of the protective device

- ▶ Carry out a risk assessment before using the safety locking device.
  - ▶ Do not tamper with or modify the components of the safety locking device.
  - ▶ Make sure that the safety locking device is only repaired by the manufacturer or by someone authorized by the manufacturer. Improper repair can lead to a loss of the protective function.
  - ▶ Make sure that switch-on commands which bring about a dangerous state of the machine are not enabled until the protective device is closed and the lock is activated.
  - ▶ Make sure that the lock is not deactivated until the dangerous state of the machine has stopped.
  - ▶ Make sure that closing a protective device and activating the lock does not cause a dangerous machine function to start by itself. This must be controlled by a separate start command.
  - ▶ The safety locking device must not be bypassed (contacts jumpered), turned away, removed, or rendered ineffective in any other way. Take measures to reduce bypassing options as necessary.
- 

If several devices are switched in succession and the simplified process according to ISO 13849 is used to determine the performance level (PL), the PL may be reduced.

A logical series connection of safe contacts may be possible up to PL d under certain circumstances. For more detailed information, see ISO TR 24119.

The safety locking device is designed so that internal errors according to ISO 13849-2, Table A4, can be ruled out.

Observe EN ISO 14119 for using interlocking devices associated with physical guards.

##### 4.1.1 Application of the safety locking device to protect people

At least one safe contact must be used for locking device monitoring (contact assignment [see table 3](#)).



#### 4.2 Operator of the machine

Changes to the electrical integration of the device in the machine controller and changes to the mechanical mounting of the device necessitate a new risk assessment. The results of this risk assessment may require the entity operating the machine to meet the obligations of a manufacturer.

The device must not be tampered with or changed, except for the procedures described in this document.

The device must not be repaired. Improper repair can result in the device not providing correct protection.

Restrict access to replacement actuators so they are not used to circumvent the device.

## 4.3 Design

---



### DANGER

Bypassing the protective device

Hazard due to lack of effectiveness of the protective device

- ▶ Eliminate any temptation to tamper with the safety locking device by implementing measures such as the following:
    - Attach safety switches with a cover or with shielding, or ensure they are out of reach.
    - Cover the safety switch and the actuator with additional equipment or protect them against access. Cover the sensor and the actuator with additional equipment or protect them against access.
- 

### 4.3.1 Selection of the actuator

---



### NOTICE

Selecting unsuitable actuators or improper mounting can damage the device.

- ▶ Select the right actuator (see table 7).
  - ▶ Pay attention to the door radius and mounting options.
- 

## 4.4 Integrating into the electrical control

Switch-on commands which bring about a dangerous state of the machine must not be enabled until the protective device is closed and the lock is activated. The lock must not be deactivated until the dangerous state has ended. Depending on the safety concept, the signal is analyzed by, e.g., safety relays or a safety controller.

The connected controller and all devices responsible for safety must comply with the required performance level and the required category (for example according to ISO 13849-1).

## 4.5 Testing plan

The safety locking device must be tested by appropriately qualified safety personnel when commissioning, after modifications, and at regular intervals.

The regular thorough checks serve to investigate the effectiveness of the safety locking device and discover defects because of modifications or external influences (such as damage or tampering).

The manufacturer and user must define the type and frequency of the thorough checks on the machine on the basis of the application conditions and the risk assessment. Determination of the thorough checks must be documented in a traceable manner.

### 5 Mounting

#### 5.1 Safety

**DANGER**

Hazard due to unexpected starting of the machine

Death or severe injury

- ▶ Make sure that the dangerous state of the machine is and remains switched off.
- 

**DANGER**

Bypassing the protective device

Hazard due to lack of effectiveness of the protective device

- ▶ Eliminate any temptation to tamper with the safety locking device by taking at least one of the following measures:
    - Attach safety switches with a cover or with shielding, or ensure they are out of reach.
    - If possible, use permanent mounting methods for actuators (e.g., welding, glue, disposable screws, or rivets).
- 

**NOTICE**

If incorrectly installed or the ambient conditions are not suitable, the safety locking device can get damaged.

- ▶ Arrange the safety switch and actuator so that damage due to unintentional outside influences is prevented.
  - ▶ Do not use safety switch and actuator.
  - ▶ The set-up and mounting of the safety switch and actuator must be stable enough to maintain proper operation.
  - ▶ Use only reliable mounting elements that can only be removed with tools.
  - ▶ If an opening is created in the physical guard due to alignment errors, it must not impair the protective function.
- 

#### 5.2 Converting the actuating head

1. Loosen screws on the cover and lift the cover.
2. Loosen the catch on the actuating head.
3. Turn the actuating head by 180°.
4. Engage actuating head.
5. Tighten the screws to 1.2 Nm.
6. Seal unused actuation slots with the supplied slot covers.

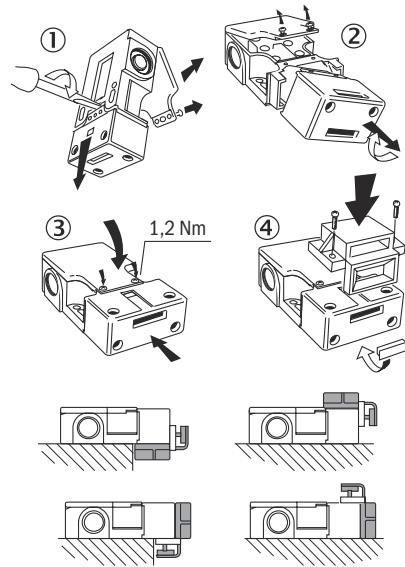

### 5.3 Mounting

1. Insert the actuator into the actuating head.
2. Connect the safety switch to the fixed part of the protective device with positive locking.
3. Connect the actuator permanently to the moving part of the protective device so it cannot be disengaged.
4. Fit an additional stop for the moving part of the protective device.

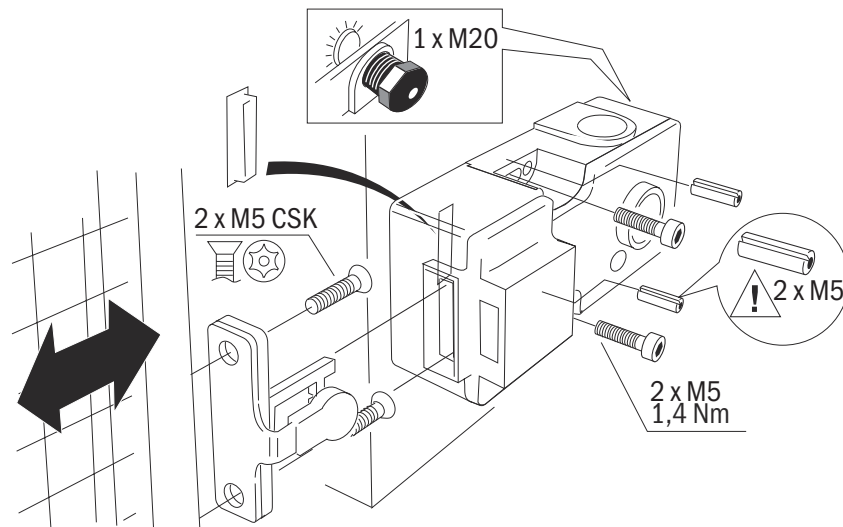

Figure 1: Mounting the safety switch

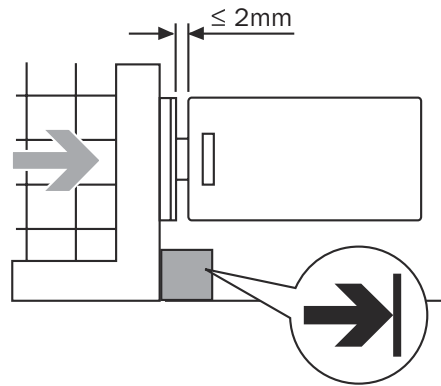

Figure 2: Mounting the actuator and the safety switch

### 5.4 Protection from environmental influences

The prerequisite for a proper and permanent safety function is protection of the actuating head from foreign bodies such as chips, sand, beams of light, etc.

When doing painting work, cover the actuation slot, the actuator and the type label.

## 6 Electrical installation

### 6.1 Safety



#### DANGER

Hazard due to electrical voltage

Death or severe injury

- ▶ Make sure that the machine and the connecting cables of the safety locking device are and remain disconnected from the power supply during the electrical installation.

#### 6.1.1 Notes on cULus

##### Devices with cable entry

For use according to the requirements of cULus, a copper wire (60/75 °C) must be used.

### 6.2 Pin assignment

Table 3: Switching elements and switching functions

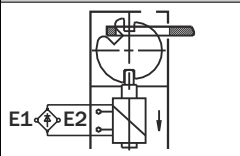
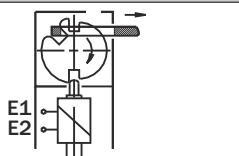
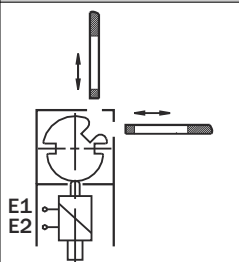
	Actuator inserted		Actuator removed
	Locking device locked	Locking device unlocked	
			
i14-M0213 Lock	♀ ⚡ 11 ⚡ 12 ⚡ 21 ⚡ 22 ⚡ 33 ⚡ 34	♀ ⚡ 11 ⚡ 12 ⚡ 21 ⚡ 22 ⚡ 33 ⚡ 34	♀ ⚡ 11 ⚡ 12 ⚡ 21 ⚡ 22 ⚡ 33 ⚡ 34
i14-M0303 Lock	♀ ⚡ 11 ⚡ 12 ⚡ 21 ⚡ 22 ⚡ 31 ⚡ 32	♀ ⚡ 11 ⚡ 12 ⚡ 21 ⚡ 22 ⚡ 31 ⚡ 32	♀ ⚡ 11 ⚡ 12 ⚡ 21 ⚡ 22 ⚡ 31 ⚡ 32
All variants	E1: +24 V DC magnet coil voltage supply (locking device) E2: +0 V DC magnet coil voltage supply (locking device)		

### 6.3 System connection (cable entry)

1. Open desired insertion opening with a suitable tool.
2. Mount the cable gland with corresponding enclosure rating.
3. Connect contacts (contact assignment [see table 3](#)).
  - Operate all contact pairs in the same voltage range.
  - Tighten terminals to 1.0 Nm.
4. Pay attention to tightness of the cable entries.
5. Close switch cover and fasten it (tightening torque 1.2 Nm).

## 7 Commissioning

### 7.1 Testing

**DANGER**

Hazard due to unexpected starting of the machine

Death or severe injury

- ▶ Before carrying out the functional test, make sure that there are no people in the hazardous area.

**Approach**

Check that the device is functioning properly after installation and after every fault. To do this, proceed as follows:

**Mechanical functional test**

- ▶ Open the protective device and close it again. The components of the safety locking device must not collide with other parts. When the protective device is closed, the actuator must be in a position which enables the lock to be actuated.

**Electrical functional test**

1. Switch on the supply voltage.
2. Close all protective devices and activate the locks. The machine must not start up on its own.
3. Check the lock. It must not be possible to open the protective device.
4. Start the machine function.
5. Make sure that the lock cannot be deactivated as long as the dangerous machine function is active.
6. Stop the machine function and deactivate the lock.
7. Check whether the protective device is kept locked until there is no more risk of injury (e.g., due to run-on movements).
8. Check the restart interlock. The machine function must not start while the lock is deactivated.
9. Repeat steps 3 to 8 individually for each protective device.

**Complementary information****NOTE**

With the version in accordance with the power to lock principle, an active lock command can be simulated by applying 24 V DC voltage to the "Lock input" contact.

### 7.2 Recurring technical checks

**DANGER**

Insufficient checks or incorrect repair

Hazard due to lack of effectiveness of the protective device

- ▶ In the event of wear or damage, replace the entire safety locking device with actuator. Never replace individual parts or assemblies.
- ▶ Check the safety locking device following the inspection intervals specified in the national rules and regulations.

The following checks must be done to ensure permanent and proper function:



- Proper switching function
- Safe mounting for all components
- No damage, contamination, deposits or wear
- Tightness of cable entries
- No loose cable connections or plug connectors
- No manipulation by employees

## 8 Decommissioning

### 8.1 Disposal

#### Approach

- ▶ Always dispose of unusable devices in accordance with national waste disposal regulations.



#### Complementary information

SICK will be glad to help you dispose of these devices on request.

## 9 Technical data

### 9.1 Technical data

Table 4: Features

Features	
Housing material	Fiberglass-reinforced polyester
Enclosure rating (IEC 60529)	IP 65
Mechanical service life	$1 \times 10^6$
B <sub>10d</sub> (EN ISO 13849)	$2 \times 10^6$ Switching operation with small load
Type	Type 2 (EN ISO 14119)
Coding level of the actuator	Low coding level (EN ISO 14119)
Ambient operating temperature	-20 °C ... +60 °C
Connection type	M20
Max. actuation speed	$9.6 \text{ m} \times \text{min}^{-1}$
Max. actuation frequency	$1,200 \times \text{h}^{-1}$
Pollution degree (external, according to EN 60947)	3
Max. actuating force at 20 °C	12 N
Locking force F <sub>max</sub>	1,000 N
Locking force F <sub>Zh</sub> according to (EN ISO 14119) (F <sub>Zh</sub> = F <sub>max</sub> /1.3)	770 N
Minimum door radii	<a href="#">see table 7</a>

Table 5: Electrical data

Electrical data	
Thermal current I <sub>th</sub>	10 A
Switching principle	Slow action switching element
Wire cross-section, (rigid/flexible)	1.5 mm <sup>2</sup>
Rated insulation voltage U <sub>i</sub>	250 V
Rated impulse withstand voltage U <sub>imp</sub>	2.5 kV
Utilization category (IEC 60947-5-1)	AC-15: 230 V, 3 A; DC-13: 24 V, 2 A
Min. switching voltage <sup>1)</sup>	5 V
Min. switching current at 24 V DC	5 mA
Conditional rated short-circuit current	100 A
Short-circuit protection (control fuse) (IEC 60269)	10 A gG
Solenoid supply voltage (+10% ... -15%)	DC +24 V
Max. solenoid power	7 W
ED switch-on time	100%

<sup>1)</sup> At 10 mA.

9.2 Dimensional drawings

i14 Lock

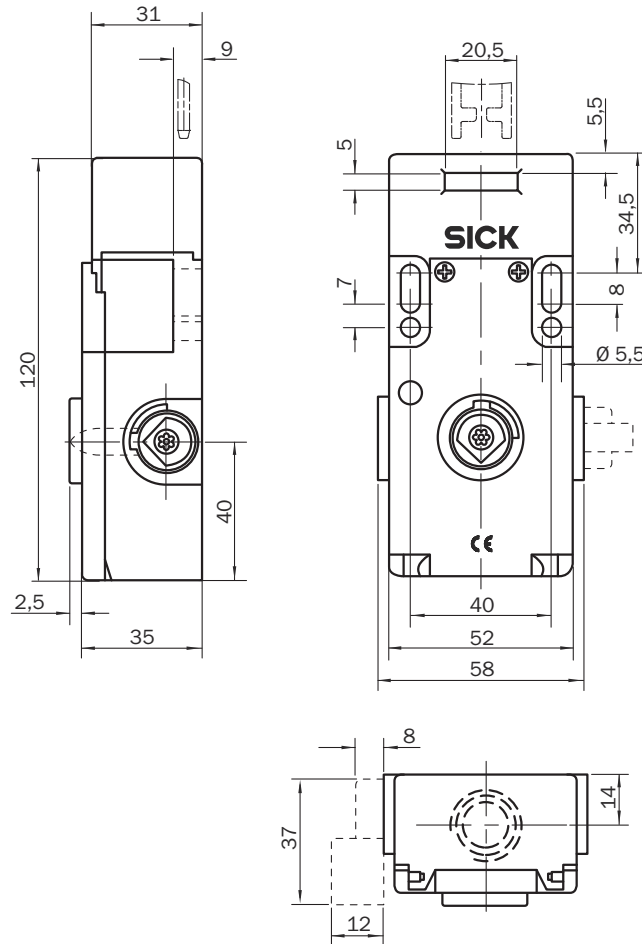

# 10 Ordering information

## 10.1 Ordering information

### i14 Lock

Table 6: Ordering information, i14 Lock

Locking device monitoring		Type code	Part number
Positive opening normally closed contact	Normally open		
2	1	i14-M0213 Lock	6025060
3	0	i14-M0303 Lock	6025062

## 11 Accessories

### 11.1 Actuator

Table 7: Actuator

Design	Actuation option	Characteristic	Door radius	Type code	Part number
Straight	Rigid	Catch spring for increased retaining force	$\geq 160 \text{ mm}$ <sup>1)</sup>	iE14-S1	5311133
Straight	Rigid	-	160 mm	iE14-S2	5320258

<sup>1)</sup> For a certain actuation direction, the door radius must be  $\geq 250 \text{ mm}$  (see figure 3).

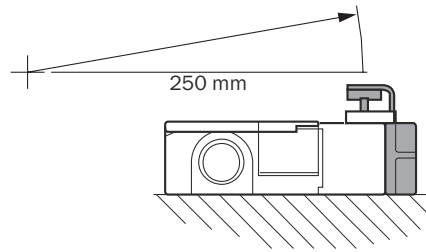

Figure 3: Actuation direction with increased door radius

### 11.2 Additional accessories

Table 8: Additional accessories

Designation	Type code	Part number
Cable gland	M20 screw connection	5309164
Mechanical unlocking mechanism	iE14-E01	5311282

## 12 Annex

### 12.1 Conformities and certificates

You can obtain declarations of conformity, certificates, and the current operating instructions for the product at [www.sick.com](http://www.sick.com). To do so, enter the product part number in the search field (part number: see the entry in the “P/N” or “Ident. no.” field on the type label).

#### 12.1.1 EU declaration of conformity

##### Excerpt

The undersigned, representing the manufacturer, herewith declares that the product is in conformity with the provisions of the following EU directive(s) (including all applicable amendments), and that the standards and/or technical specifications stated in the EU declaration of conformity have been used as a basis for this.

- ROHS DIRECTIVE 2011/65/EU
- MACHINERY DIRECTIVE 2006/42/EC

#### 12.1.2 UK declaration of conformity

##### Excerpt

The undersigned, representing the following manufacturer herewith declares that this declaration of conformity is issued under the sole responsibility of the manufacturer. The product of this declaration is in conformity with the provisions of the following relevant UK Statutory Instruments (including all applicable amendments), and the respective standards and/or technical specifications have been used as a basis.

- Restriction of the Use of Certain Hazardous Substances in Electrical and Electronic Equipment Regulations 2012
- Supply of Machinery (Safety) Regulations 2008

**Australia**

Phone +61 (3) 9457 0600  
1800 33 48 02 – tollfree  
E-Mail sales@sick.com.au

**Austria**

Phone +43 (0) 2236 62288-0  
E-Mail office@sick.at

**Belgium/Luxembourg**

Phone +32 (0) 2 466 55 66  
E-Mail info@sick.be

**Brazil**

Phone +55 11 3215-4900  
E-Mail comercial@sick.com.br

**Canada**

Phone +1 905.771.1444  
E-Mail cs.canada@sick.com

**Czech Republic**

Phone +420 234 719 500  
E-Mail sick@sick.cz

**Chile**

Phone +56 (2) 2274 7430  
E-Mail chile@sick.com

**China**

Phone +86 20 2882 3600  
E-Mail info.china@sick.net.cn

**Denmark**

Phone +45 45 82 64 00  
E-Mail sick@sick.dk

**Finland**

Phone +358-9-25 15 800  
E-Mail sick@sick.fi

**France**

Phone +33 1 64 62 35 00  
E-Mail info@sick.fr

**Germany**

Phone +49 (0) 2 11 53 010  
E-Mail info@sick.de

**Greece**

Phone +30 210 6825100  
E-Mail office@sick.com.gr

**Hong Kong**

Phone +852 2153 6300  
E-Mail ghk@sick.com.hk

**Hungary**

Phone +36 1 371 2680  
E-Mail ertekesites@sick.hu

**India**

Phone +91-22-6119 8900  
E-Mail info@sick-india.com

**Israel**

Phone +972 97110 11  
E-Mail info@sick-sensors.com

**Italy**

Phone +39 02 27 43 41  
E-Mail info@sick.it

**Japan**

Phone +81 3 5309 2112  
E-Mail support@sick.jp

**Malaysia**

Phone +603-8080 7425  
E-Mail enquiry.my@sick.com

**Mexico**

Phone +52 (472) 748 9451  
E-Mail mexico@sick.com

**Netherlands**

Phone +31 (0) 30 229 25 44  
E-Mail info@sick.nl

**New Zealand**

Phone +64 9 415 0459  
0800 222 278 – tollfree  
E-Mail sales@sick.co.nz

**Norway**

Phone +47 67 81 50 00  
E-Mail sick@sick.no

**Poland**

Phone +48 22 539 41 00  
E-Mail info@sick.pl

**Romania**

Phone +40 356-17 11 20  
E-Mail office@sick.ro

**Russia**

Phone +7 495 283 09 90  
E-Mail info@sick.ru

**Singapore**

Phone +65 6744 3732  
E-Mail sales.gsg@sick.com

**Slovakia**

Phone +421 482 901 201  
E-Mail mail@sick-sk.sk

**Slovenia**

Phone +386 591 78849  
E-Mail office@sick.si

**South Africa**

Phone +27 10 060 0550  
E-Mail info@sickautomation.co.za

**South Korea**

Phone +82 2 786 6321/4  
E-Mail infokorea@sick.com

**Spain**

Phone +34 93 480 31 00  
E-Mail info@sick.es

**Sweden**

Phone +46 10 110 10 00  
E-Mail info@sick.se

**Switzerland**

Phone +41 41 619 29 39  
E-Mail contact@sick.ch

**Taiwan**

Phone +886-2-2375-6288  
E-Mail sales@sick.com.tw

**Thailand**

Phone +66 2 645 0009  
E-Mail marcom.th@sick.com

**Turkey**

Phone +90 (216) 528 50 00  
E-Mail info@sick.com.tr

**United Arab Emirates**

Phone +971 (0) 4 88 65 878  
E-Mail contact@sick.ae

**United Kingdom**

Phone +44 (0)17278 31121  
E-Mail info@sick.co.uk

**USA**

Phone +1 800.325.7425  
E-Mail info@sick.com

**Vietnam**

Phone +65 6744 3732  
E-Mail sales.gsg@sick.com

Detailed addresses and further locations at [www.sick.com](http://www.sick.com)

