

MRS6000

3D LiDAR sensors

SICK
Sensor Intelligence.



Described product

MRS6000

Manufacturer

SICK AG
Erwin-Sick-Str. 1
79183 Waldkirch
Germany

Legal information

This work is protected by copyright. Any rights derived from the copyright shall be reserved for SICK AG. Reproduction of this document or parts of this document is only permissible within the limits of the legal determination of Copyright Law. Any modification, abridgment or translation of this document is prohibited without the express written permission of SICK AG.

The trademarks stated in this document are the property of their respective owner.

© SICK AG. All rights reserved.

Original document

This document is an original document of SICK AG.



Contents

1	About this document.....	5
1.1	Information on the operating instructions.....	5
1.2	Explanation of symbols.....	5
1.3	Further information.....	6
2	Safety information.....	7
2.1	Intended use.....	7
2.2	Improper use.....	7
2.3	Cybersecurity.....	7
2.4	Limitation of liability.....	7
2.5	Modifications and conversions.....	8
2.6	Requirements for skilled persons and operating personnel.....	8
2.7	Operational safety and specific hazards.....	8
3	Product description.....	10
3.1	Scope of delivery.....	10
3.2	Status indicators.....	10
3.3	Type code.....	10
3.4	Product identification.....	11
3.5	Principle of operation.....	12
3.5.1	Measurement principle.....	12
3.5.2	Range finding.....	13
3.5.3	Direction measurement.....	13
3.5.4	Impact of object surfaces on the measurement.....	13
3.5.5	Object size.....	15
3.5.6	Multi-echo analysis.....	16
3.5.7	Filter.....	17
3.5.8	Multi-layer technology.....	18
3.5.9	Scan data output.....	18
3.5.10	RSSI values.....	19
4	Transport and storage.....	21
4.1	Transport.....	21
4.2	Unpacking.....	21
4.3	Transport inspection.....	21
4.4	Storage.....	21
5	Mounting.....	23
5.1	Mounting instructions.....	23
5.2	Mounting device.....	23
5.3	Mounting multiple devices.....	23
6	Electrical installation.....	24
6.1	Wiring instructions.....	24
6.2	Connecting the device electrically.....	25

6.3	Prerequisites for safe operation of the device.....	27
7	Operation.....	30
7.1	Operation with SOPAS ET.....	30
7.2	Operation using SOPASair.....	34
7.2.1	Activating Extended measuring range.....	34
7.3	ROS driver.....	35
8	Maintenance.....	36
8.1	Maintenance plan.....	36
8.2	Cleaning.....	36
9	Troubleshooting.....	37
9.1	General faults, warnings, and errors.....	37
9.2	Repairs.....	37
9.3	Returns.....	37
9.4	Disposal.....	37
10	Technical data.....	38
10.1	Features.....	38
10.2	Performance.....	39
10.3	Interfaces.....	39
10.4	Mechanics/electronics.....	39
10.5	Ambient data.....	40
10.6	General notes.....	41
11	Accessories.....	42
12	Annex.....	43
12.1	Declarations of conformity and certificates.....	43
12.2	Licenses.....	43

1 About this document

1.1 Information on the operating instructions

These operating instructions provide important information on how to use devices from SICK AG.

Prerequisites for safe work are:

- Compliance with all safety notes and handling instructions supplied.
- Compliance with local work safety regulations and general safety regulations for device applications

The operating instructions are intended to be used by qualified personnel and electrical specialists.



NOTE

Read these operating instructions carefully to familiarize yourself with the device and its functions before commencing any work.

The operating instructions are an integral part of the product. Store the instructions in the immediate vicinity of the device so they remain accessible to staff at all times. Should the device be passed on to a third party, these operating instructions should be handed over with it.

These operating instructions do not provide information on operating the machine or system in which the device is integrated. Information on this can be found in the operating instructions for the machine or system.

1.2 Explanation of symbols

Warnings and important information in this document are labeled with symbols. Signal words introduce the instructions and indicate the extent of the hazard. To avoid accidents, damage, and personal injury, always comply with the instructions and act carefully.



DANGER

... indicates a situation of imminent danger, which will lead to a fatality or serious injuries if not prevented.



WARNING

... indicates a potentially dangerous situation, which may lead to a fatality or serious injuries if not prevented.



CAUTION

... indicates a potentially dangerous situation, which may lead to minor/slight injuries if not prevented.



NOTICE

... indicates a potentially harmful situation, which may lead to material damage if not prevented.



NOTE

... highlights useful tips and recommendations as well as information for efficient and trouble-free operation.

1.3 Further information



NOTE

Further documentation for the device can be found on the online product page at:

- www.sick.com/MRS6000

There, additional information has been provided depending on the product, such as:

- Model-specific online data sheets for device types, containing technical data, dimensional drawing, and specification diagrams
 - Declarations of conformity and certificates of the product family
 - Dimensional drawings and 3D CAD dimension models of the device types in various electronic formats
 - Other publications related to the devices described here
 - Publications dealing with accessories
-

2 Safety information

2.1 Intended use

The 3D LiDAR sensor MRS6000 reliably detects its surroundings over 24 layers using a high density of scan points and an aperture angle of 120°. Its special mirror technology also ensures a high level of scan stability. Using the multi-echo technology, the LiDAR sensor scans through rain, dust and fog, while simultaneously multiplying the point density. These properties are especially suitable for complete creation of a 3D point cloud that can be used to solve many complex applications.

Typical application areas are, for example, anti-collision monitoring and rear area monitoring in industrial (autonomous) vehicles, person counts in passenger locks, monitoring of land and buildings, volume monitoring, automated guided vehicle systems for outdoors, robot area, traffic and park management systems.

SICK AG assumes no liability for losses or damage arising from the use of the product, either directly or indirectly. This applies in particular to use of the product that does not conform to its intended purpose and is not described in this documentation.

2.2 Improper use

Any use outside of the stated areas, in particular use outside of the technical specifications and the requirements for intended use, will be deemed to be incorrect use.

- The device does not constitute a safety component in accordance with the respective applicable safety standards for machines.
- The device must not be used in explosion-hazardous areas, in corrosive environments or under extreme environmental conditions.
- Any use of accessories not specifically approved by SICK AG is at your own risk.



WARNING

Danger due to improper use!

Any improper use can result in dangerous situations.

Therefore, observe the following information:

- Product should be used only in accordance with its intended use.
- All information in these operating instructions must be strictly observed.
- Shut down the product immediately in case of damage.

2.3 Cybersecurity

To protect against cybersecurity threats, it is necessary to continuously monitor and maintain a comprehensive and holistic cybersecurity concept. A suitable concept comprises organizational, technical, procedural, electronic, and physical levels of defense and provides suitable measures for different types of risks. SICK's products and solutions must be viewed as a component of this concept.

Information on Cybersecurity can be found at: www.sick.com/psirt.

2.4 Limitation of liability

Relevant standards and regulations, the latest technological developments, and our many years of knowledge and experience have all been taken into account when compiling the data and information contained in these operating instructions. The manufacturer accepts no liability for damage caused by:

- Non-adherence to the product documentation (e.g., operating instructions)
- Incorrect use
- Use of untrained staff
- Unauthorized conversions or repair
- Technical modifications
- Use of unauthorized spare parts, consumables, and accessories

2.5 Modifications and conversions



NOTICE

Modifications and conversions to the device may result in unforeseeable dangers.

Interrupting or modifying the device or SICK software will invalidate any warranty claims against SICK AG. This applies in particular to opening the housing, even as part of mounting and electrical installation.

2.6 Requirements for skilled persons and operating personnel



WARNING

Risk of injury due to insufficient training.

Improper handling of the device may result in considerable personal injury and material damage.

- All work must only ever be carried out by the stipulated persons.

The following qualifications are required for various activities:

Table 1: Activities and technical requirements

Activities	Qualification
Mounting, maintenance	<ul style="list-style-type: none"> ■ Basic practical technical training ■ Knowledge of the current safety regulations in the workplace
Electrical installation, device replacement	<ul style="list-style-type: none"> ■ Practical electrical training ■ Knowledge of current electrical safety regulations ■ Knowledge of the operation and control of the devices in their particular application
Commissioning, configuration	<ul style="list-style-type: none"> ■ Basic knowledge of the computer operating system used ■ Basic knowledge of the design and setup of the described connections and interfaces ■ Basic knowledge of data transmission
Operation of the device for the particular application	<ul style="list-style-type: none"> ■ Knowledge of the operation and control of the devices in their particular application ■ Knowledge of the software and hardware environment for the particular application

2.7 Operational safety and specific hazards

Please observe the safety notes and the warnings listed here and in other sections of this product documentation to reduce the possibility of risks to health and avoid dangerous situations.

**CAUTION****Optical radiation: Class 1 Laser Product**

The accessible radiation does not pose a danger when viewed directly for up to 100 seconds. It may pose a danger to the eyes and skin in the event of incorrect use.

- Do not open the housing. Opening the housing may increase the level of risk.
- Current national regulations regarding laser protection must be observed.

Caution – Use of controls or adjustments or performance of procedures other than those specified herein may result in hazardous radiation exposure.

It is not possible to entirely rule out temporary disorienting optical effects, particularly in conditions of dim lighting. Disorienting optical effects may come in the form of dazzle, flash blindness, afterimages, photosensitive epilepsy, or impairment of color vision, for example.

**WARNING****Electrical voltage!**

Electrical voltage can cause severe injury or death.

- Work on electrical systems must only be performed by qualified electricians.
- The power supply must be disconnected when attaching and detaching electrical connections.
- The product must only be connected to a voltage supply as set out in the requirements in the operating instructions.
- National and regional regulations must be complied with.
- Safety requirements relating to work on electrical systems must be complied with.

**WARNING****Risk of injury and damage caused by potential equalization currents!**

Improper grounding can lead to dangerous equipotential bonding currents, which may in turn lead to dangerous voltages on metallic surfaces, such as the housing. Electrical voltage can cause severe injury or death.

- Work on electrical systems must only be performed by qualified electricians.
- Follow the notes in the operating instructions.
- Install the grounding for the product and the system in accordance with national and regional regulations.

**WARNING****Electric shock!**

Non-insulated electrical conductors are located in the housing. Electrical voltage can cause severe injury or death.

- Do not open the housing.
- Protect the housing from damage.
- If the housing is damaged, disconnect the device from the voltage supply and do not put it into operation.

**CAUTION****Hazardous radiation!**

Caution – Use of controls or adjustments or performance of procedures other than those specified herein may result in hazardous radiation exposure.

3 Product description

3.1 Scope of delivery

The delivery of the device includes the following components:

Table 2: Scope of delivery

Item	Component	Comments
1	Device in the version ordered	Depending on version Without connecting cables and brackets
1	Set of protective caps for electrical connections	Attached to the connections
1	Printed safety notes, multilingual	Brief information and general safety notes

3.2 Status indicators

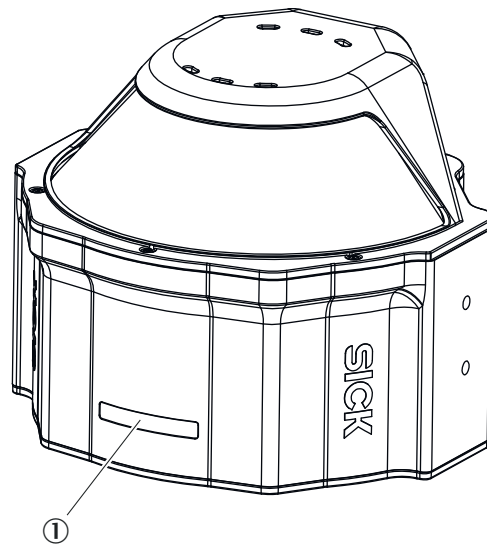

Figure 1: Status indicators

① Status LEDs

Table 3: Display behavior of the LED

Orange LED	Green LED	Red LED	Yellow LED	Status
		●		Initialization
	●		☀	Configuration
☀	●			Note (service recommended)
	●	☀		Warning (service required)
	●	●		Risk (malfunction)
	●		●	On / Ready for operation
	●			Data transmission

● = illuminated; ☀ = flashing

3.3 Type code

The devices of the MRS6000 product family are arranged according to the following type code:

MRS	a	b	cc	d	-	e	f	g	...
1	2	3	4	5		6	7	8	...

Table 4: Type code

Position	Description	Characteristic
1	Device name type	Multilayer Range Sensor
2	Device type	6: MRS6000
3	Version (10% range & FOV)	1: 30m @10%, FOV 120° 2: 1.4 x (typ.) the standard scanning range, FOV 120° (Extended range mode)
4	Modules	24: Multibeam 24L
5	Application	R: Ranging
6	Housing version	0: Housing IP65 1: Housing IP67 9: Special version
7	Connection	3: Connector fixed 3 x M12 9: Special version
8	Application package	5: Ranging 9: Special version
...



NOTE

Not all combinations are possible according to the type code. The available device variants can be found online at:

- www.sick.com/MRS6000

3.4 Product identification

Type label

The following information can be read from the type label on the device:

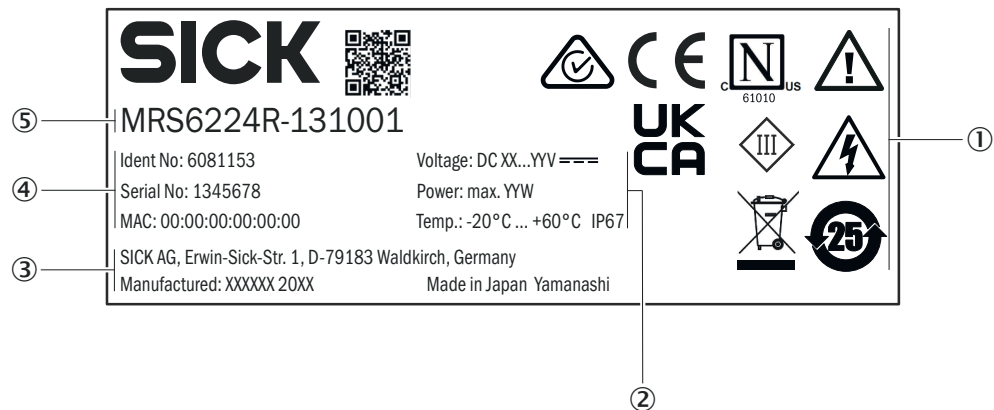

Figure 2: MRS6000 type label (example)

- ① QR code with product data, approval symbol, test mark, warning symbol: observe the operating instructions!, electrical voltage!
- ② Technical data
- ③ Manufacturer address, production date, production location
- ④ Part number, serial number, MAC address
- ⑤ Type code

3.5 Principle of operation

3.5.1 Measurement principle

The device is an optoelectronic LiDAR sensor that contactlessly scans the outline of its surroundings with the help of laser beams. The device measures its surroundings in two-dimensional polar coordinates, relative to its measurement origin. This is marked by a circular indentation in the center of the optics cover. If a laser beam strikes an object, the position of that object is determined in terms of distance and angle.

With the MRS6000, this is done in 24 layers. Here, 4 scan planes with 6 layers each are detected one after the other.

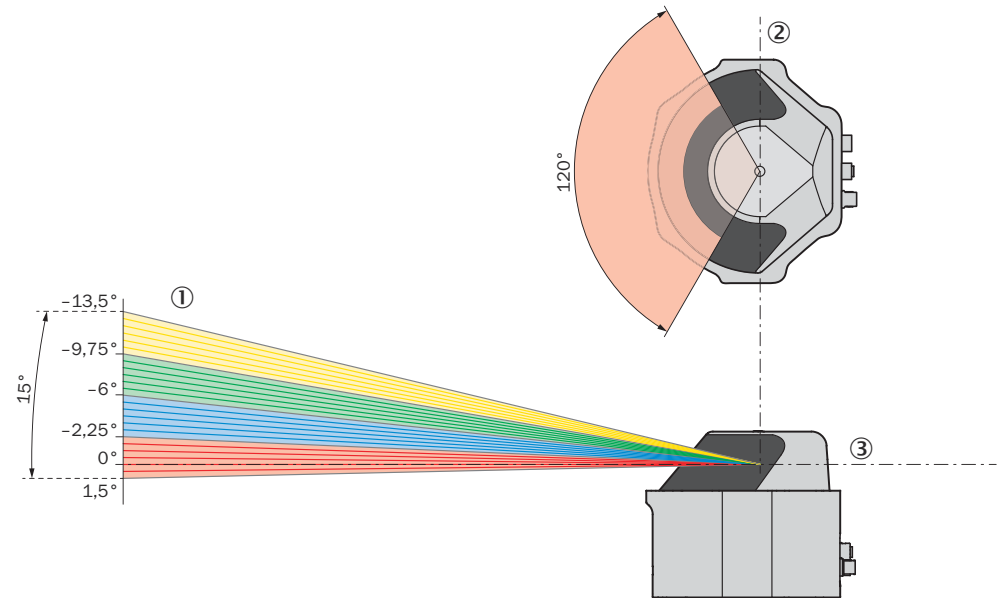

Figure 3: Principle of operation

- ① 4 scan planes with 6 layers each
- ② Vertical axis
- ③ Horizontal axis

The angular resolution is 0.13° . This produces a fine network of measuring points (3D point cloud) for the scanned working range (120° horizontal, 15° vertical).

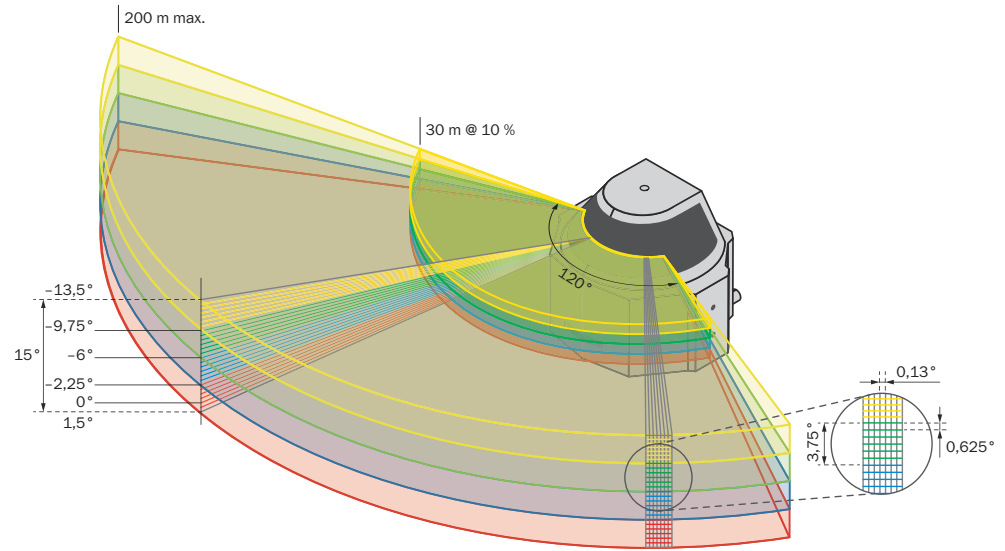
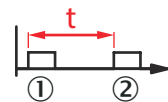

Figure 4: Principle of operation, 3D display

3.5.2 Range finding

The device emits beams pulsed by a laser diode. If the laser beam is reflected by an object, the reflected beam is received by the sensor.

The distance to the object is calculated on the basis of the time that the pulsed light beam requires to be reflected and received by the sensor.



- ① Send pulse
- ② Receive pulse

3.5.3 Direction measurement

The laser beams are emitted using 4 internally rotating polygon mirrors and scan the surroundings orbitally on 4 planes. The measured values are assigned to the associated angular cut, and thus to the direction, by 6 receive elements.

3.5.4 Impact of object surfaces on the measurement

The received signal from a perfectly diffuse reflection from a white surface (diffuse Lambertian reflector) corresponds to a remission of 100%. By this definition, surfaces that reflect the light in bundles (specular surfaces, reflectors) have remissions of over 100%.

Reflection

Most surfaces produce a diffuse reflection of the laser beam in all directions. The structure (smooth or rough), shape (flat or curved), and color (light or dark) of the surface determine how well the laser beam is reflected.

On very rough surfaces, a large proportion of the energy is lost due to absorption. Curved surfaces produce a higher diffusion. Dark surfaces reflect the laser beam worse than light ones (brilliant white plaster reflects approx. 100% of the light, while black

foam rubber reflects approx. 2.4%). The aforementioned surface characteristics can reduce the scanning range of the device, in particular for surfaces with low remission values.

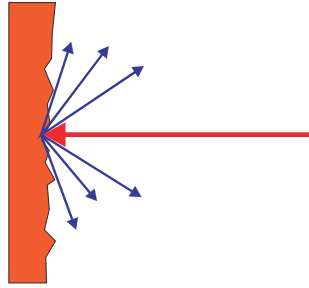

Figure 5: Reflection of light on the surface of the object

Angle of reflection

The angle of reflection corresponds to the angle of incidence. If the laser beam hits a surface at right angles, the energy is optimally reflected. If the laser beam hits a surface at an oblique angle, energy and range are lost accordingly.

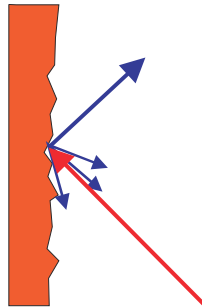

Figure 6: Angle of reflection

Retroreflection

If the reflective energy is greater than 100%, the beam is not reflected diffusely in all directions; instead it is reflected in a targeted way (retroreflection). Thus a large part of the emitted energy can be received by the laser distance measurer. Plastic reflectors (cat's eyes), reflective tape, and triple prisms have these properties.

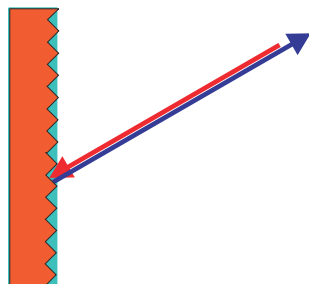

Figure 7: Retroreflection

Reflective surfaces

The laser beam is almost completely deflected on reflective surfaces. This means that an object hit by the deflected beam may be detected instead of the reflective surface.

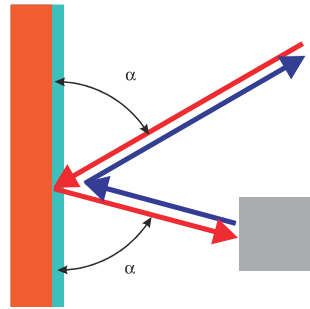

Figure 8: Specular surfaces

Small objects

Objects that are smaller than the diameter of the laser beam cannot reflect the laser light's full energy. The portion of the light beam that does not reach the object is lost. If all of the light reflected to the sensor is insufficient, the object may not be detected.

The portion of the light that does not reach the front object can be reflected by a larger object in the background. If all of the light reflected to the sensor is sufficient, this object is detected. This can lead to a corruption of the measured value.

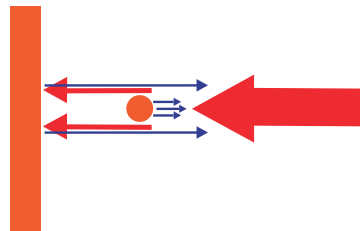

Figure 9: Object smaller than the laser beam diameter

3.5.5 Object size

Light spot divergence

As the distance from the device increases, the laser beam expands. As a result, the dimension of the light spot on the surface of the object.



Characteristic	Value
Light spot divergence	2.1 mrad (horizontal) x 65.4 mrad (vertical)
Light spot size on the front screen of the device	0.25 mm (horizontal) x 8.0 mm (vertical)
Light spot size at a distance of 25 m	0.05 m (horizontal) x 1.64 m (vertical)

Formula for calculating the light spot width:

Light spot divergence [rad] x Distance [mm] + Light spot width at the n device cover [mm] = Light spot width [mm]

Formula for calculating the height of the light spot:

Light spot divergence [rad] x Distance [mm] + Light spot height at the n device cover [mm] = Light spot width [mm]

This results in a light spot size of 52.8 mm x 1,643 mm for a distance of 25 m, for example.

The high angular resolution and the 24 layers enable scans that have practically no gaps.

At a distance of 25 m, the distance between two light spots in the horizontal axis is only approx. 1 mm. Each light spot is detected by 6 receive diodes, whereby 6 measuring points are produced per light spot.

Due to the angular resolution of 0.13° , 924 measuring points are detected per layer in a scan (120°).

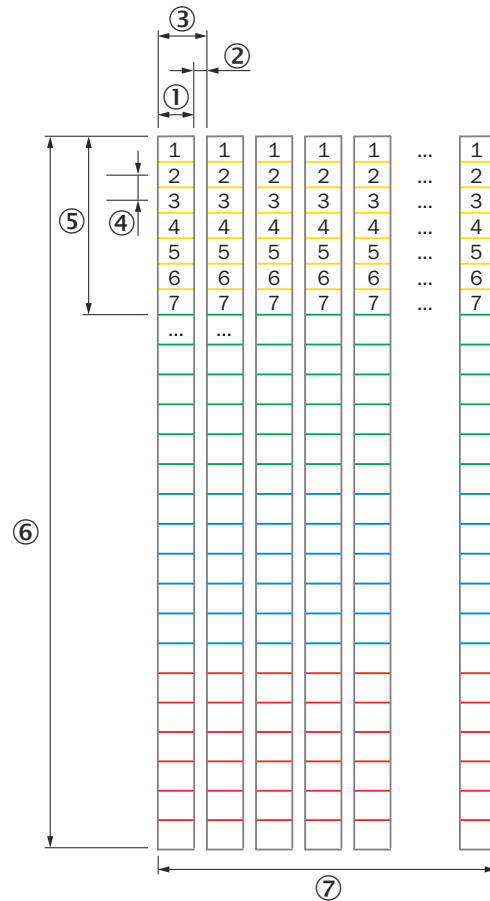

Figure 10: MRS6000 light spot and measuring points

- ① Light spot width / measuring point width (56.6 mm at distance of 25 m)
- ② Distance between 2 measuring points (approx. 1 mm at distance of 25 m)
- ③ Minimum object size (56.7 mm at distance of 25 m)
- ④ Vertical distance between 2 measuring points (272 mm at distance of 25 m)
- ⑤ Light spot height (1641 mm at distance of 25 m)
- ⑥ Vertical detection range = 4x light spot height (6401 mm at distance of 25 m)
- ⑦ Horizontal detection range (923 measuring points above 120°)

3.5.6 Multi-echo analysis

The distance between the device and an object is calculated via the time-of-flight of the emitted pulse. The MRS6000 can evaluate up to four echo signals for each measuring beam to deliver reliable measurement results, even under adverse ambient conditions.

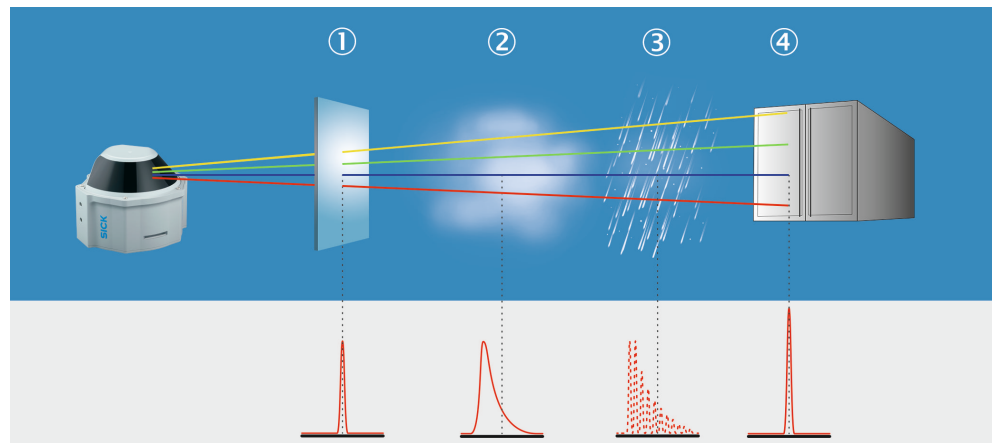

Figure 11: Multi-echo analysis

- ① Glass pane
- ② Fog
- ③ Rain
- ④ Measuring object

3.5.7 Filter

By using digital filters to pre-process and optimize the measured distance values, the device can be tailored to the specific requirements of the respective application. This makes it possible to prevent virtually all faults.

You can arbitrarily combine the filters. If several filters are active, then the filters are applied sequentially to the results of the preceding filter. Processing occurs in the following sequence: echo filter, particle filter, ground reference evaluation. It should be noted, however, that the measurement data output may be delayed due to the multiple calculation steps.

The active filter functions affect the output measured values. It is not possible to recalculate the original measured values from the filtered output values.

Echo filter

The echo filter screens out unwanted measurement data and signals caused by rain, dust, snow, and other ambient conditions. You can set whether the first, the last, or all three echoes are output. The other pulses triggered by undesirable ambient conditions are not taken into account.

- **First echo:** The field evaluation evaluates the first echo. In the measured value output the first echo is output in the telegram.
- **Last echo:** The field evaluation evaluates the last echo. In the measured value output the last echo is output in the telegram.
- **All echoes:** The field evaluation evaluates the first echo. In the measured value output all echoes are output in the telegram.

Particle filter

The particle filter blanks small, irrelevant reflection pulses in dusty environments and in rain or snow which are caused by dust particles, raindrops, snowflakes or the like. It should be noted that the particle filter functionality is only available on the first or last echo and at distances of a maximum of 30 m.

Ground detection

Ground detection recognizes objects lying on the road, as well as steps or depressions. The sensitivity of the filter can be adjusted to different road surfaces, from smooth/level (-) to rough/uneven (+).

It should be noted that the ground detection functionality is only available on the first or last echo and at distances of a maximum of 30 m. If the condition of the surface is defined as rough/uneven, flat objects lying on the ground may not be classified as objects.

3.5.8 Multi-layer technology

The multi-layer technology of the device allows compensation of the pitch angle through 24 layers at different vertical angles, when attached to a vehicle for example. In this way, the device detects the object reliably, for example even when the vehicle accelerates or brakes.

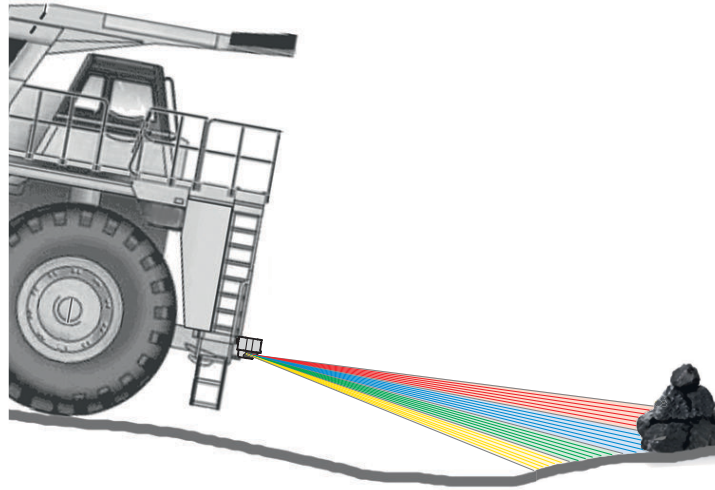

3.5.9 Scan data output

The device has 4 polygon mirrors that each detect one plane. 6 layers are detected per plane.

The data is output for each scan. Every 100 ms, the data is output with 24 telegrams in each case (1 telegram per layer). The duration of data output for all data of a scan depends on the connection speed. At the highest transmission speed (1 GBit Ethernet), the output duration is approx. 8 ms.

Marks for scan (scan counter), plane (time stamp) and layer (layer angle) are included in the data telegram for data assignment.

Data telegram (example):

```

1 <STX>sSN LMDscandata 1 0 10736D01 0 0 1CC0 56BB 86BD0263 88BFBE92 F0 0 0 0 F5B2 3E8 ...
2 <STX>sSN LMDscandata 1 0 10736D01 0 0 1CC1 56BB 86BD0263 86BFC40A F0 0 0 0 F62F 3E8 ...
3 <STX>sSN LMDscandata 1 0 10736D01 0 0 1CC2 56BB 86BD0263 86BFC88F F0 0 0 0 F6AC 3E8 ...
4 <STX>sSN LMDscandata 1 0 10736D01 0 0 1CC3 56BB 86BD0263 86BFCD77 F0 0 0 0 F729 3E8 ...
5 <STX>sSN LMDscandata 1 0 10736D01 0 0 1CC4 56BB 86BD0263 86BFD252 F0 0 0 0 F7A6 3E8 ...
6 <STX>sSN LMDscandata 1 0 10736D01 0 0 1CC5 56BB 86BD0263 86BFD51C F0 0 0 0 F823 3E8 ...
7 <STX>sSN LMDscandata 1 0 10736D01 0 0 1CC6 56BB 86BD640B 86BFDAE7 F0 0 0 0 F8A0 3E8 ...
8 <STX>sSN LMDscandata 1 0 10736D01 0 0 1CC7 56BB 86BD640B 86BFDF8F F0 0 0 0 F91D 3E8 ...
... ..

```

```
23 <STX>sSN LMDscandata 1 0 10736D01 0 0 1CD6 56BB 86BE275B 86C01C1C F0 0 0 0 70 3E8 ...
24 <STX>sSN LMDscandata 1 0 10736D01 0 0 1CD7 56BB 86BE275B 86C01F29 F0 0 0 0 ED 3E8 ...
```

Scan (scan counter):

- Lines 1 to 24: **56BB** = 22203
- The scan number is a consecutive number. All 24 layers of a scan have the same scan number.

Layer (time stamp):

- Lines 1 to 6: **86BS0263** = 2.260,533,859 = 2,260.533.859 ms
- Lines 7, 8 (... to 12): **86BD640B** = 2,260.558.859 = 2,260.558.859 ms
- The time stamp is a time specified in milliseconds (start of measurement of a layer since switching on the device). All 6 layers of a scan have the same time stamp. The difference between 2 consecutive planes of a scan is 25 ms.

Layer (layer angle):

- Line 1: **F5B2** = -2638 (corresponds to -13.19°) = Position 24
- Line 2: **F62F** = -2513 (corresponds to -12.565°) = Position 23
- Line 23: **70** = 112 (corresponds to 0.56°) = Position 2
- Line 24: **ED** = 237 (corresponds to 1.185°) = Position 1
- The layer address is an angle specified in degrees (horizontal angle, physical). The difference between 2 consecutive layers of a scan is 0.625° .

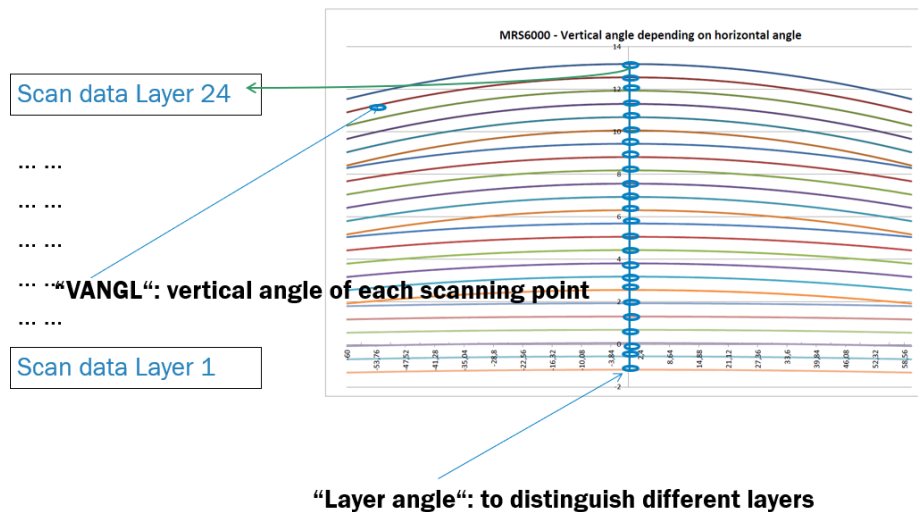

3.5.10 RSSI values

RSSI (Received Signal Strength Indicator) is the measure of the signal strength that the device receives. This value is determined for each measurement and has a logarithmic, arbitrary unit.

The RSSI values have a resolution of 16 bits with whole-number values between 1 and 65535, where 1 stands for the weakest signal and 65534 for the strongest signal (e.g. with one reflector).

A value of 65535 means “dazzled”. The value 0 (zero) means that the received energy was too low to produce a valid RSSI value. A valid distance measurement has at least an RSSI of 1.

If the RSSI value is 0, then no distance measurement is possible. There can be two reasons for this:

- The target object lies outside the sensing range.
- The target object has an extremely low remission.

Please note that white paper can have very similar values as a reflector at a short distance.

The RSSI values can vary slightly among different devices and during the service life of the device.

4 Transport and storage

4.1 Transport

For your own safety, please read and observe the following notes:



NOTICE

Damage to the product due to improper transport.

- The device must be packaged for transport with protection against shock and damp.
- Recommendation: Use the original packaging as it provides the best protection.
- Transport should be performed by trained specialist staff only.
- The utmost care and attention is required at all times during unloading and transportation on company premises.
- Note the symbols on the packaging.
- Do not remove packaging until immediately before you start mounting.

4.2 Unpacking

- To protect the device against condensation, allow it to equilibrate with the ambient temperature before unpacking if necessary.
- Handle the device with care and protect it from mechanical damage.
- To avoid ingress of dust and water, only remove the protective elements, e.g. protective caps of the electrical connections just before attaching the connecting cable.

4.3 Transport inspection

Immediately upon receipt in Goods-in, check the delivery for completeness and for any damage that may have occurred in transit. In the case of transit damage that is visible externally, proceed as follows:

- Do not accept the delivery or only do so conditionally.
- Note the scope of damage on the transport documents or on the transport company's delivery note.
- File a complaint.



NOTE

Complaints regarding defects should be filed as soon as these are detected. Damage claims are only valid before the applicable complaint deadlines.

4.4 Storage

Store the device under the following conditions:

- Recommendation: Use the original packaging.
- Electrical connections are provided with a protective cap (as in the delivery condition).
- Do not store outdoors.
- Store in a dry area that is protected from dust.
- To allow any residual dampness to evaporate, do not package in airtight containers.
- Do not expose to any aggressive substances.
- Protect from sunlight.
- Avoid mechanical shocks.

- Storage temperature: [see "Technical data", page 38.](#)
- Relative humidity: [see "Technical data", page 38.](#)
- For storage periods of longer than 3 months, check the general condition of all components and packaging on a regular basis.

5 Mounting

5.1 Mounting instructions

- Observe the technical data.
- Protect the sensor from direct sunlight.
- To prevent condensation, avoid exposing the device to rapid changes in temperature.
- The mounting site has to be designed for the weight of the device.
- Protect the device from moisture, contamination, and damage.
- Make sure that the status indicator is clearly visible.
- Do not install the device at a location that can be easily accessed by unauthorized persons.
- The front screen of the device must not be subjected to strong forces (> 1 joule), such as impact, for example.
- The device must be protected from impacts, vibrations, the effect of shocks, and other mechanical and chemical influences.

5.2 Mounting device

1. Attach the mounting bracket at the desired position. Mounting brackets are available as accessories, [see "Accessories", page 42](#).
 2. Make the electrical connection. Attach and tighten a voltage-free cable, [see "Connecting the device electrically", page 25](#).
 3. Mount the device at the bracket using the fixing holes provided ([see figure 20, page 40](#)). Always fasten the device with 4 screws, tightening torque: 5.2 Nm.
 4. Switch on the supply voltage.
- ✓ Following successful initialization, the green status LEDs light up. The device is ready for use.

5.3 Mounting multiple devices



NOTICE

Risk of interference from other devices!

Radiation sources with a wavelength of 870 nm can cause interference if they affect the device directly.

The device has been designed to minimize the probability of mutual interference with devices of the same type. To rule out even the slightest effects on the measurement accuracy, the devices should be arranged such the laser beams are not received by another device.

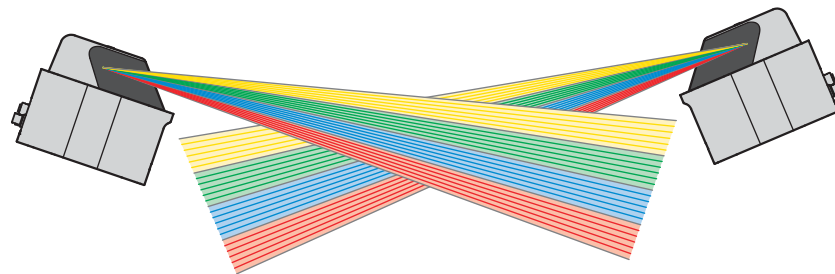

Figure 12: Arrangement for 2 devices

6 Electrical installation

6.1 Wiring instructions



NOTE

Pre-assembled cables can be found online at:

- www.sick.com/MRS6000
-



NOTICE

Faults during operation and device or system defects!

Incorrect wiring may result in operational faults and defects.

- Follow the wiring notes precisely.
-

Observe the following notes to ensure safe and trouble-free operation:

- Connect the connecting cables in a de-energized state. Do not switch on the supply voltage until installation is complete and all connecting cables have been connected to the device and control.
- Wire cross-sections in the supply cable from the customer's power system should be designed in accordance with the applicable standards. Use copper cables with a cross-section of at least 0.25 mm² (approx. 24 AWG).
- Protect the device with an external slow-blow fuse of 3 A at the beginning of the supply cable, viewed from the voltage supply.
- All electric circuits connected to the device must be designed as SELV or PELV circuits (SELV = Safety Extra Low Voltage, PELV = Protective Extra Low Voltage).
- The specified enclosure rating of the device when mounted is reached only if suitable mating connectors or protective caps are used.
- Do not open the screwed housing of the device, since the warranty will then become void.
- Prior to connecting the I/O line, check the device configuration for the inputs/ outputs.
- Avoid tensile loads to the connecting cables.

- The ground is connected to the housing, so an additional insulation is required:

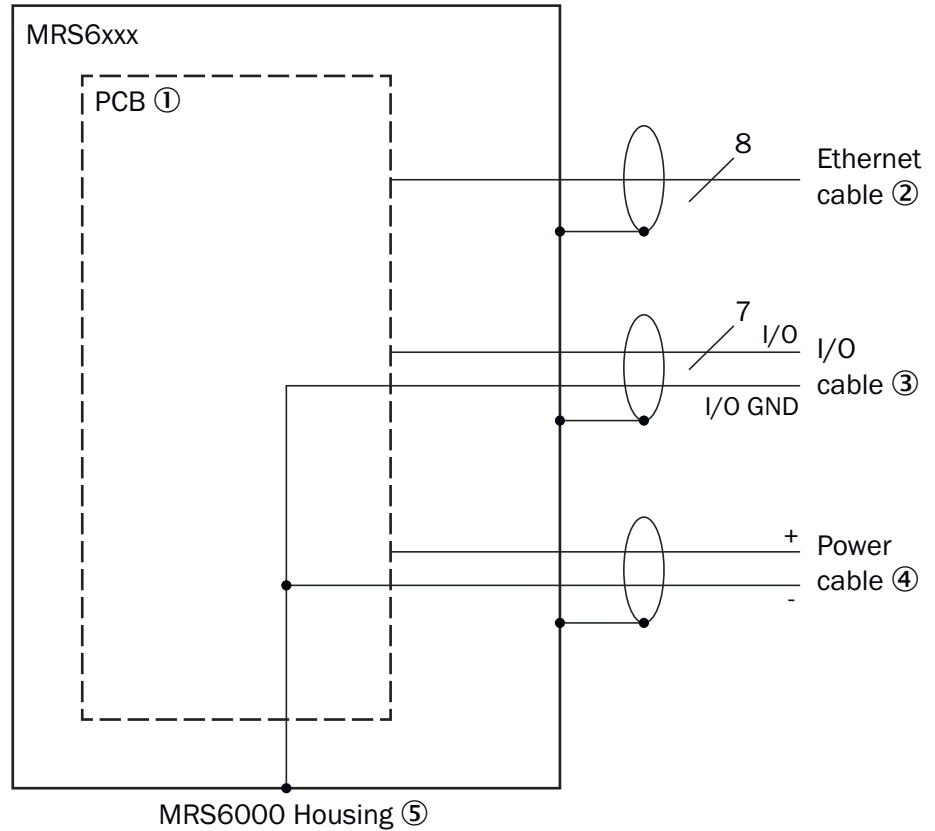

Figure 13: Ground concept

- ① Circuit board
- ② Ethernet connecting cable
- ③ I/O connecting cable
- ④ Power connecting cable
- ⑤ Device housing MRS6000

6.2 Connecting the device electrically



NOTICE

All electrical circuits must be connected to the device with safety or protective extra-low voltage (SELV or PELV).

- Ensure that the voltage supply is not connected.
- Connect the device according to the connection diagram.
- Observe the wiring instructions, see "[Wiring instructions](#)", page 24.

Power connection

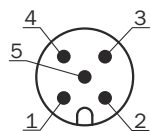

Figure 14: Male connector, M12, 5-pin, A-coded

Table 5: Pin assignment connection Power

Pin	Identification	Description
1	Vs	Supply voltage: +10 ... +29 V DC
2	-	Reserved
3	GND	Supply voltage: 0 V
4	IN8/OUT8	Digital input 8 / digital output 8
5	-	Reserved

I/O connection

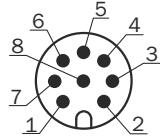

Figure 15: Male connector, M12, 8-pin, A-coded

Table 6: Pin assignment I/O connection

Pin	Identification	Description
1	IN1/OUT1	Digital input 1 / digital output 1
2	IN2/OUT2	Digital input 2 / digital output 2
3	IN3/OUT3	Digital input 3 / digital output 3
4	IN4/OUT4	Digital input 4 / digital output 4
5	IN5/OUT5	Digital input 5 / digital output 5
6	IN6/OUT6	Digital input 6 / digital output 6
7	GND INx/OUTx	Ground, digital input / digital output
8	IN7/OUT7	Digital input 7 / digital output 7

Ethernet connection

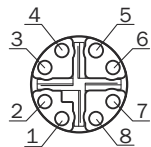

Figure 16: Female connector M12, 8-pin, X-coded

Table 7: Pin assignment connection Ethernet

Pin	Identification	Description
1	D1+	Data1 +
2	D1-	Data1 -
3	D2+	Data2 +
4	D2-	Data2 -
5	D4+	Data4 +
6	D4-	Data4 -
7	D3-	Data3 -
8	D3+	Data3 +

6.3 Prerequisites for safe operation of the device



WARNING

Risk of injury and damage caused by electrical current!

As a result of equipotential bonding currents between the device and other grounded devices in the system, faulty grounding of the device can give rise to the following dangers and faults:

- Dangerous voltages are applied to the metal housings.
- Devices will behave incorrectly or be destroyed.
- Cable shielding will be damaged by overheating and cause cable fires.

Remedial measures

- Only skilled electricians should be permitted to carry out work on the electrical system.
- If the cable insulation is damaged, disconnect the voltage supply immediately and have the damage repaired.
- Ensure that the ground potential is the same at all grounding points.
- Where local conditions do not meet the requirements for a safe earthing method, take appropriate measures. For example, ensure low-impedance and current-carrying equipotential bonding.

The device is connected to the peripheral devices (any local trigger sensor(s), system controller) via shielded cables. The cable shield – for the data cable, for example – rests against the metal housing of the device.

The device can be grounded through the cable shield or through a blind tapped hole in the housing, for example.

If the peripheral devices have metal housings and the cable shields are also in contact with their housings, it is assumed that all devices involved in the installation have the **same ground potential**.

This is achieved by complying with the following conditions:

- Mounting the devices on conductive metal surfaces
- Correctly grounding the devices and metal surfaces in the system
- If necessary: low-impedance and current-carrying equipotential bonding between areas with different ground potentials

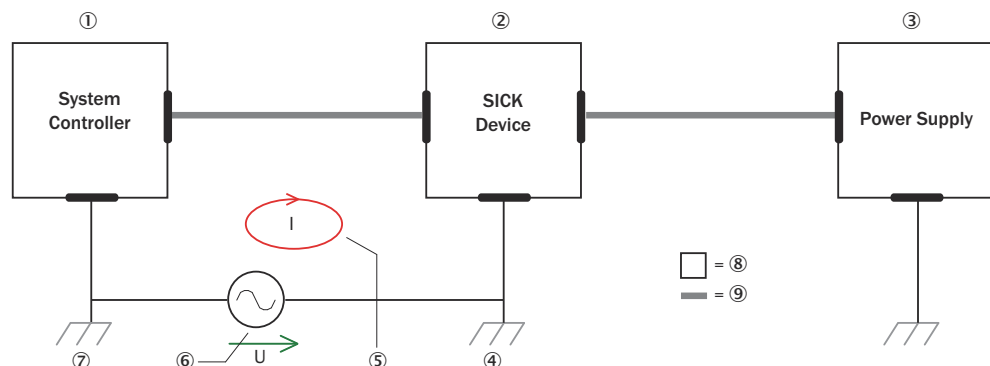

Figure 17: Example: Occurrence of equipotential bonding currents in the system configuration

- ① System controller
- ② Device
- ③ Voltage supply
- ④ Grounding point 2
- ⑤ Closed current loop with equalizing currents via cable shield

- ⑥ Ground potential difference
- ⑦ Grounding point 1
- ⑧ Metal housing
- ⑨ Shielded electrical cable

If these conditions are not fulfilled, equipotential bonding currents can flow along the cable shielding between the devices due to differing ground potentials and cause the hazards specified. This is, for example, possible in cases where there are devices within a widely distributed system covering several buildings.

Remedial measures

The most common solution to prevent equipotential bonding currents on cable shields is to ensure low-impedance and current-carrying equipotential bonding. If this equipotential bonding is not possible, the following solution approaches serve as a suggestion.



NOTICE

We expressly advise against opening up the cable shields. This would mean that the EMC limit values can no longer be complied with and that the safe operation of the device data interfaces can no longer be guaranteed.

Measures for widely distributed system installations

On widely distributed system installations with correspondingly large potential differences, the setting up of local islands and connecting them using commercially available **electro-optical signal isolators** is recommended. This measure achieves a high degree of resistance to electromagnetic interference.

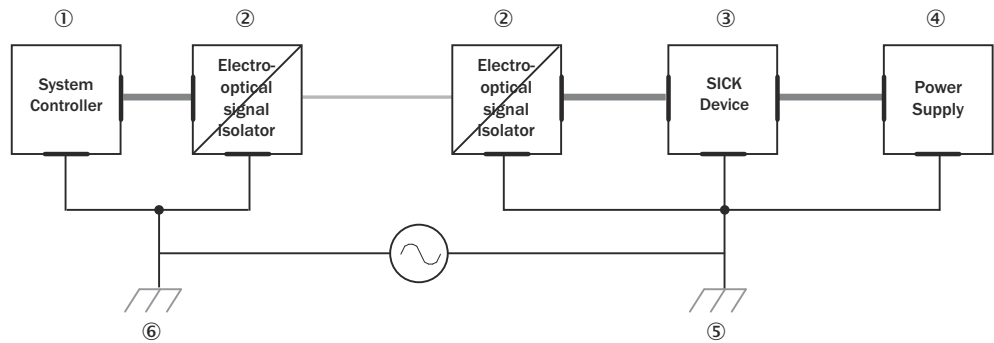

□ = ⑦ — = ⑧ — = ⑨

Figure 18: Example: Prevention of equipotential bonding currents in the system configuration by the use of electro-optical signal isolators

- ① System controller
- ② Electro-optical signal isolator
- ③ Device
- ④ Voltage supply
- ⑤ Grounding point 2
- ⑥ Grounding point 1
- ⑦ Metal housing
- ⑧ Shielded electrical cable
- ⑨ Optical fiber

The use of electro-optical signal isolators between the islands isolates the ground loop. Within the islands, a stable equipotential bonding prevents equalizing currents on the cable shields.

Measures for small system installations

For smaller installations with only slight potential differences, insulated mounting of the device and peripheral devices may be an adequate solution.

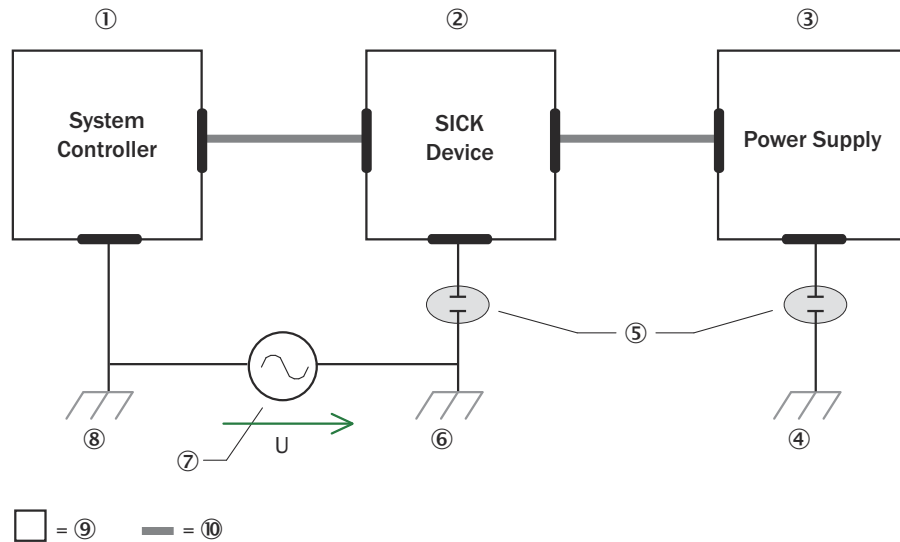

Figure 19: Example: Prevention of equipotential bonding currents in the system configuration by the insulated mounting of the device

- ① System controller
- ② Device
- ③ Voltage supply
- ④ Grounding point 3
- ⑤ Insulated mounting
- ⑥ Grounding point 2
- ⑦ Ground potential difference
- ⑧ Grounding point 1
- ⑨ Metal housing
- ⑩ Shielded electrical cable

Even in the event of large differences in the ground potential, ground loops are effectively prevented. As a result, equalizing currents can no longer flow via the cable shields and metal housing.



NOTICE

The voltage supply for the device and the connected peripheral devices must also guarantee the required level of insulation.

Under certain circumstances, a tangible potential can develop between the insulated metal housings and the local ground potential.

7 Operation

7.1 Operation with SOPAS ET

Version 3.3.3 and higher of the SOPAS Engineering Tool (SOPAS ET) software can be used to configure the device and for service and diagnostic purposes.



NOTE

The Extend measuring range function can only be activated via SOPASair see "[Operation using SOPASair](#)", page 34.

To configure the device, you will require a computer with SOPAS ET installed and a free Ethernet connection. Alternatively, the connection can be established via a USB connection using an Ethernet USB adapter.



NOTE

The most up-to-date version of the SOPAS ET software can be downloaded from www.sick.com/SOPAS_ET. The respective system requirements for installing SOPAS ET are also specified there.

1. Connect the communication interface (Ethernet, 8-pin M12 female connector) of the device to the computer.
 2. Switch on and start the computer.
 3. Supply the device with voltage (5-pin M12 male connector, supply voltage 10 ... 29 V DC).
- ✓ The status LED lights up after successful initialization. The device is ready for use.



NOTE

To use SOPAS ET with the device, you need a device description file (SDD) for this device. You can install this within SOPAS ET using the device catalog. The device description file is saved on the device and can be installed there. Alternatively, installation is possible from the SICK website (Internet connection required).

Following installation of the device description file, the device can be selected from the device catalog and added to a project.

A connection to the device is established via the communication interface. The connection must be activated for data transmission (**online**).

Certain functions (e.g., Edit parameters) require you to be logged in to the device:

i > **Device** > **Login** > Select user level and enter password:

User levels	Password
Maintenance	Main
Authorized client	Client
Service	Service level

Information about the device is displayed in the device window and the device can also be configured here (**Device**> **Open** menu).



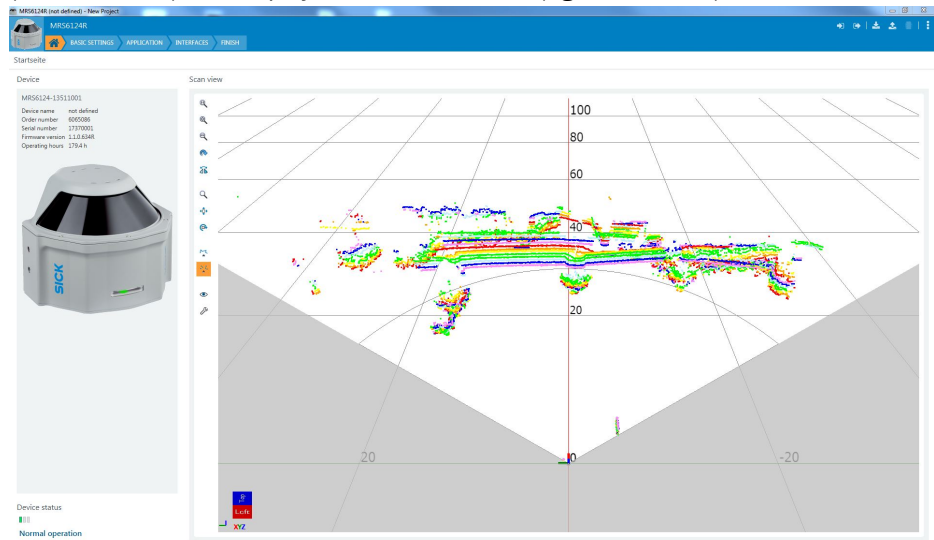

Description of the device window

The device window features various views supporting a selection of functions:

-  (Start): Start device configuration with display of information about the device (left-hand side) and display of the current scan (right-hand side).



The scan view can be customized with the assistance of various tools (to the left of the scan view), for example:

- : Resets scan display to default view.
-  / : Displays measured values as points or lines.
- : Freely rotates scan display.

- **Default settings:** Scan display (left-hand side), indicates the device parameters (right-hand side):

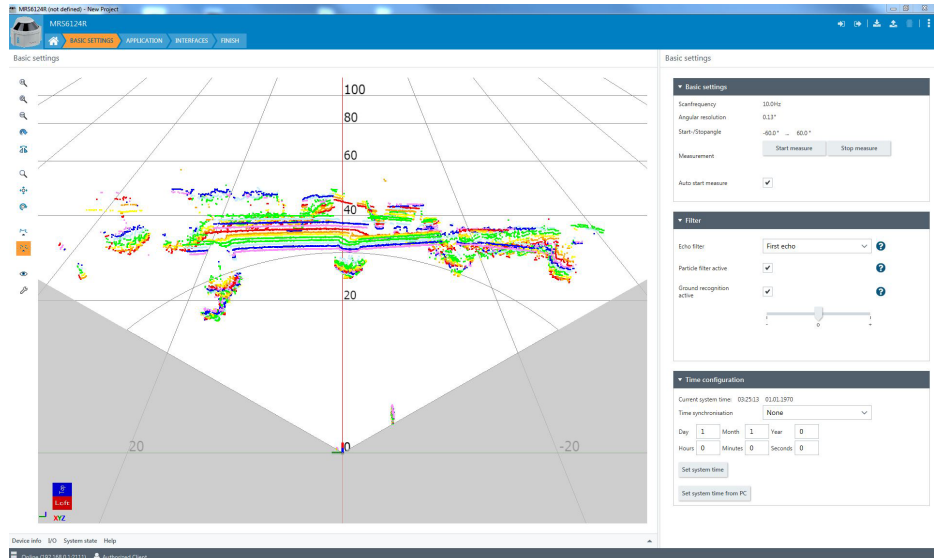

- **Application:** Scan display (left-hand side) and input of detection parameters (right-hand side):

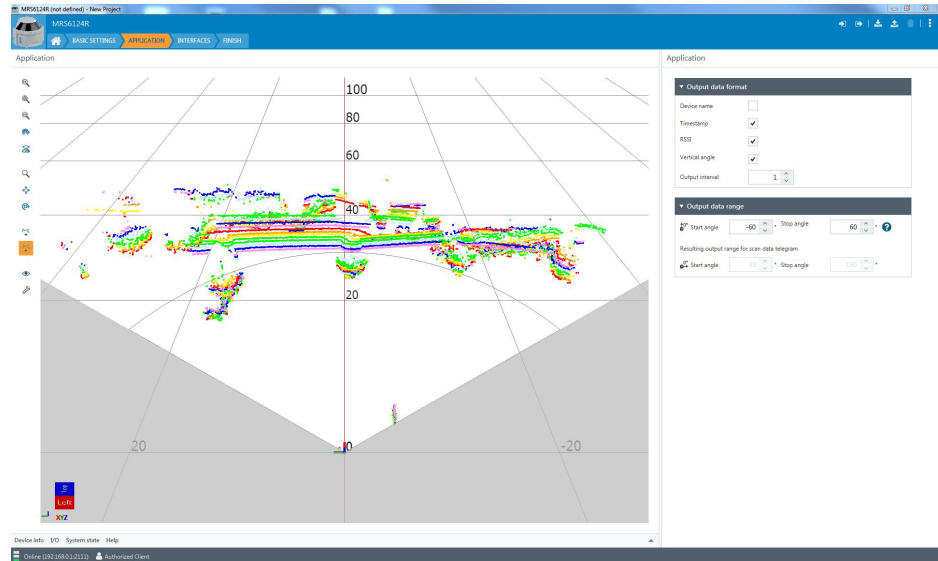

- **Interfaces:** Configuration of the interfaces (left-hand side) and input of communication parameters (right-hand side).

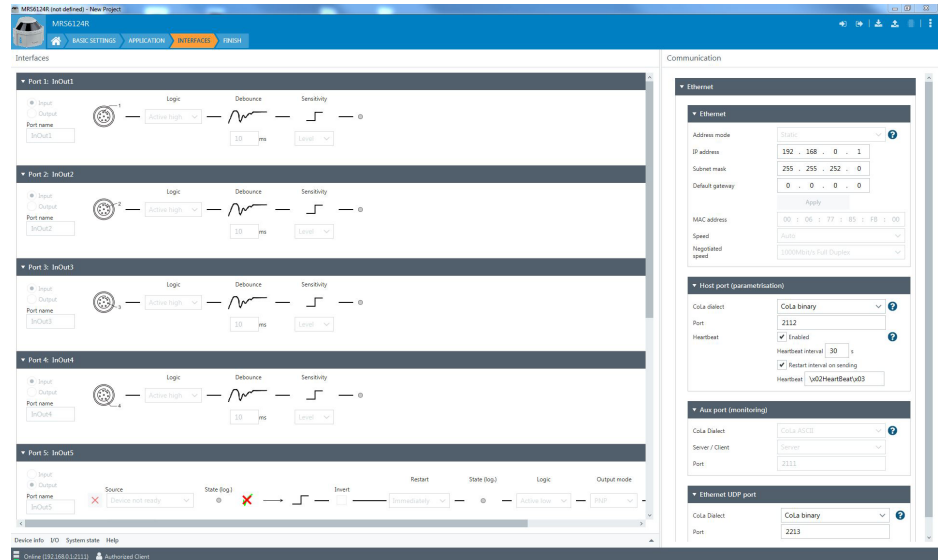

Communication with the device can take place via different Ethernet ports:

2111: This port is configured to CoLa-A as standard. It is fully functional for configuration and data output. Intended use is device configuration. The CoLa-A protocol would enable the output of scan data on this port but would require a lot of computing time and bandwidth.

2112: This port is configured to CoLa-B as standard. It is fully functional for configuration and data output. Intended use is as a customer interface, including for data communication (output of scan data).

2122: This port works with the CoLa-2 protocol. It is fully functional for configuration and data output and supports all improvements to the CoLa-2 protocol.

2213: This port works with UDP/CoLa-B as standard. It is fully functional for configuration and data output. Intended use is as a rapid customer interface for real-time applications.



NOTE

A detailed description of the telegrams is provided in the publication Telegram Listing Ranging sensors (English, No. 8014631).

7.2 Operation using SOPASair

The device has a web server that you can access using an Internet browser.

SOPASair enables you to display device data and configuration settings. The **Extended measuring range** function can also be activated here.



NOTE

Other functions cannot be parameterized via SOPASair. Use SOPAS ET for this [see "Operation with SOPAS ET", page 30.](#)

The following browsers are supported:

- Internet Explorer (version 11 or higher)
- Google Chrome (version 49 or higher)

1. Start browser.
2. Enter the device IP address.
- ✓ The SOPASair user interface is displayed.

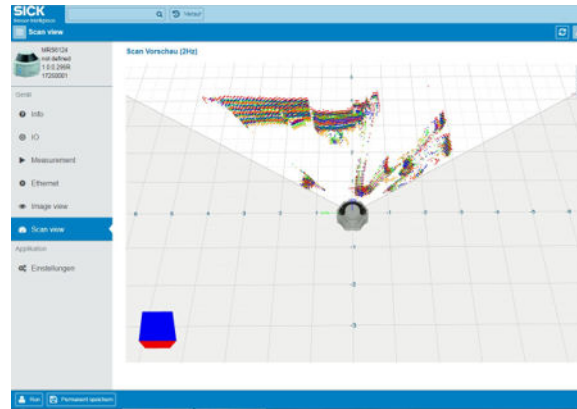

7.2.1 Activating Extended measuring range



NOTE

Other functions cannot be parameterized via SOPASair. Use SOPAS ET for this [see "Operation with SOPAS ET", page 30.](#)

User levels

The device has different user levels.

The current user level is displayed in the lower area of the user interface.

1. Click on the display of the current user level.
- ✓ The **Login** input dialog opens.
2. Select user level (**Username**), enter password (**Password**) and click on **LOGIN**.

User levels	Password	User/Authorizations
Run	-	Customers: Display only, no configuration
AuthorizedClient	client	Technical staff: Install and configure device

User levels	Password	User/Authorizations
Service	servicelevel	Service staff: Make advanced configuration settings

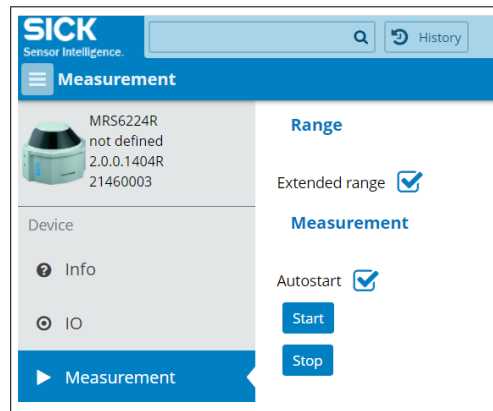

1. Select **Measurement** in the menu.
2. Select the **Extended measuring range** checkbox.

7.3 ROS driver

Suitable drivers for integrating the device into the ROS (Robot Operating System) are available for download on the product page:

www.sick.com/MRS6000

8 Maintenance

8.1 Maintenance plan

During operation, the device works maintenance-free.

Depending on the assignment location, the following preventive maintenance tasks may be required for the device at regular intervals:

Table 8: Maintenance plan

Maintenance work	Interval	To be carried out by
Check device and connecting cables for damage at regular intervals.	Depends on ambient conditions and climate.	Specialist
Clean housing.	Depends on ambient conditions and climate.	Specialist
Clean housing and viewing window.	Depends on ambient conditions and climate.	Specialist
Check the screw connections and plug connectors.	Depends on the place of use, ambient conditions or operating requirements. Recommended: At least every 6 months.	Specialist
Check that all unused connections are sealed with protective caps.	Depends on ambient conditions and climate. Recommended: At least every 6 months.	Specialist

8.2 Cleaning



NOTICE

Equipment damage due to improper cleaning.

Improper cleaning may result in equipment damage.

- Only use recommended cleaning agents and tools.
 - Never use sharp objects for cleaning.
-
- ▶ Use a damp, soft cloth for cleaning to avoid scratching the surface of the optics cover. A mild cleaning agent can be used in the event of contamination. **Do not** use solvent cleaner! **Do not** use cleaning agents containing alcohol (e.g. isopropyl alcohol)!

9 Troubleshooting

9.1 General faults, warnings, and errors

Possible errors and corrective actions are described in the table below. In the case of errors that cannot be rectified using the information below, please contact the SICK Service department. To find your agency, see the final page of this document.



NOTE

Before calling, make a note of all type label data such as type designation, serial number, etc., to ensure faster telephone processing.

Table 9: Troubleshooting questions and replies

Question / status	Response / remedial actions
Red LED lights up	Device fault: Read out the fault code via the PC software SOPAS ET and remedy the cause of the fault.
Reference target is no longer detected or the measurement data exhibit anomalies	Front screen contaminated: Clean the screen.

9.2 Repairs

Repair work on the device may only be performed by qualified and authorized personnel from SICK AG. Interruptions or modifications to the device by the customer will invalidate any warranty claims against SICK AG.

9.3 Returns

- ▶ Only send in devices after consulting with SICK Service.
- ▶ The device must be sent in the original packaging or an equivalent padded packaging.



NOTE

To enable efficient processing and allow us to determine the cause quickly, please include the following when making a return:

- Details of the contact person
- Description of the application
- Description of the fault that occurred

9.4 Disposal

If a device can no longer be used, dispose of it in an environmentally friendly manner in accordance with the applicable country-specific waste disposal regulations. Do not dispose of the product along with household waste.



NOTICE

Danger to the environment due to improper disposal of the device.

Disposing of devices improperly may cause damage to the environment.

Therefore, observe the following information:

- Always observe the national regulations on environmental protection.
- Separate the recyclable materials by type and place them in recycling containers.

10 Technical data



NOTE

The relevant online data sheet for your product, including technical data, dimensional drawing, and connection diagrams can be downloaded, saved, and printed from the Internet:

- www.sick.com/MRS6000

Please note: This documentation may contain further technical data.

10.1 Features

	MRS6124R-131001	MRS6224R-131001
Version	Long range	
Application	Outdoor	
Light source	Infrared (wavelength 870 nm, max. output power 44 W, pulse duration 10.5 ns)	
Laser class	1 (EN/IEC 60825-1:2014)	1 (EN/IEC 60825-1:2014) ¹⁾
Aperture angle	120° horizontal 15° vertical	
Scanning frequency	10 Hz	
Angular resolution	0.13° horizontal 0.625° vertical	
Working range	0.5 m ... 200 m	
Scanning range	30 m at remission 90 m at 90% remission	30 m at 10% remission factor (x1.4 (typ.) in sensitivity mode) 90 m at 90% remission factor (x1.4 in sensitivity mode)
Number of echoes evaluated	4	

¹⁾ For MRS6224R-131001 only: This laser product is rated as a class 1 laser according to IEC 60825-1:2014. In some cases, evaluation is required according to the older IEC 60825-1:2007 standard, e.g. by employers in the EU according to Directive 2006/25 / EC. According to the older IEC 60825-1:2007 standard, laser class 3R must be used as the basis.

Working range diagram

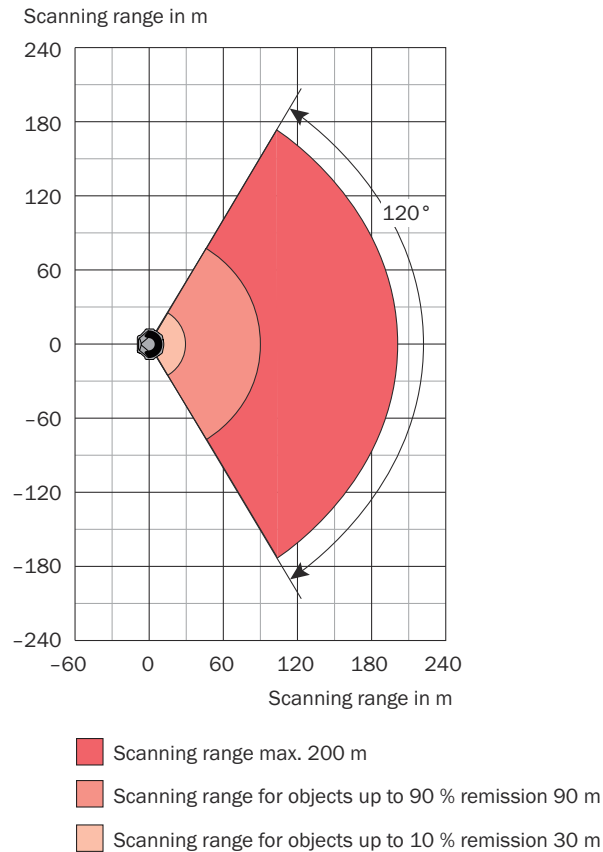

10.2 Performance

Systematic error	$\pm 125 \text{ mm}^{1)}$
Statistical error	$30 \text{ mm}^{1)}$
Distance resolution	6.25 cm

¹⁾ Typical value; actual value depends on ambient conditions

10.3 Interfaces

Ethernet

Type	Ethernet, TCP/IP, UDP/IP
Function	Raw data interface/parameterization, NTP
Data transmission rate	100 Mbit/s ... 1 Gbit/s

10.4 Mechanics/electronics

	MRS6124R-131001	MRS6224R-131001
Electrical connection	3 x round connector M12 (supply voltage, Ethernet, I/O)	
Supply voltage	10 V ... 29 V	
Power consumption	20 W	
Housing	Aluminum / plastic (PMMA)	
Enclosure rating	IP65 / IP67	
Protection class	III	

	MRS6124R-131001	MRS6224R-131001
Weight	2.2 kg	2.4 kg
Shock resistance	Enclosure rating IK 06 as per IEC 62262 ¹⁾	
Dimensions (L x W x H)	164.3 mm x 176 mm x 132 mm	

1) The product has been tested under the following conditions and it has been confirmed safe under these conditions:

- Impact test condition: rated output 1 Joule.
- The housings of the product are cooled down to -20 °C and tested within 10 minutes.
- A smooth steel ball with a mass of 500 g ± 25 g and a diameter of ca. 50 mm is dropped onto the product from a height of 200 mm.

Dimensional drawing

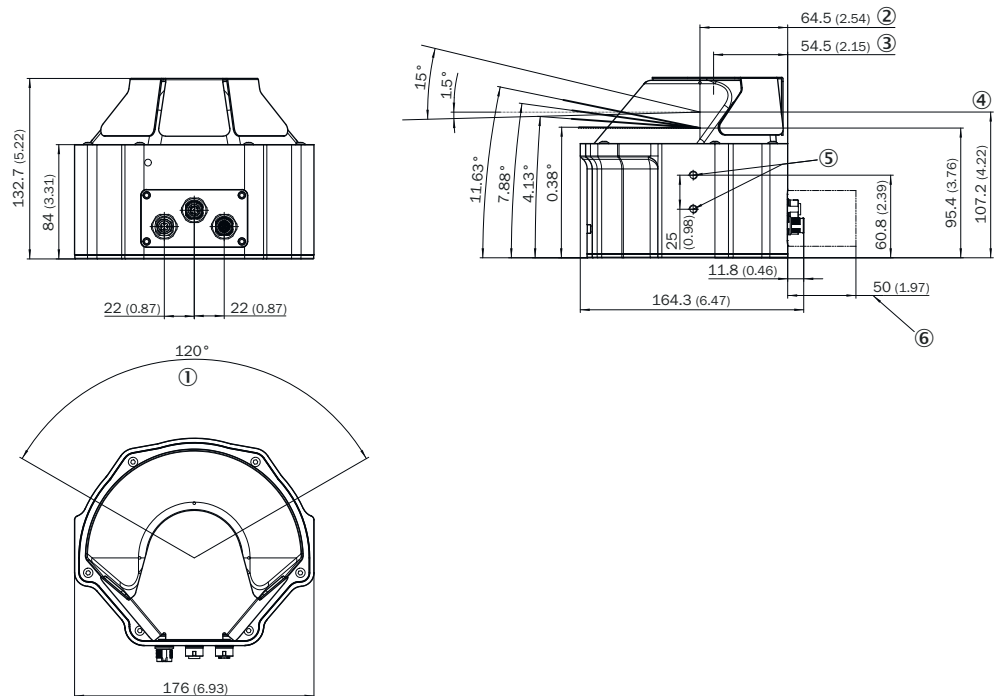

Figure 20: Dimensional drawing of the MRS6000; dimensions in mm (inch), decimal separator: period

- ① Aperture angle 120°
- ② Zero point
- ③ Rotation axis
- ④ Horizontal axis
- ⑤ Mounting holes M6 x 10 mm
- ⑥ Area to be kept free for connecting cables
- ⑦ Device center of gravity
- ⑧ Measurement origin

10.5 Ambient data

Ambient operating temperature	-20 °C ... +60 °C
Storage temperature	-30 °C ... +70 °C
Operating and storage air humidity	Max air humidity (non-condensing)
Ambient light immunity	100,000 lux

10.6 General notes

Note concerning usage	The sensor does not constitute a safety component in accordance with the respective applicable safety standards for machines.
------------------------------	---

11 Accessories



NOTE

Accessories and, if applicable, mounting information can be found online at:

- www.sick.com/MRS6000
-

12 Annex

12.1 Declarations of conformity and certificates

The declarations of conformity and certificates can be downloaded from the Internet at:

- www.sick.com/MRS6000

12.2 Licenses

SICK uses open source software which is published by the rights holders under a free license. Among others, the following license types are used: GNU General Public License (GPL version 2, GPL version 3), GNU Lesser General Public License (LGPL), MIT license, zlib license and licenses derived from the BSD license.

This program is provided for general use without warranty of any kind. This warranty disclaimer also extends to the implicit assurance of marketability or suitability of the program for a particular purpose.

More details can be found in the GNU General Public License.

For license texts see www.sick.com/licensetexts.

Printed copies of the license texts are also available on request.

Australia

Phone +61 (3) 9457 0600
1800 33 48 02 – tollfree
E-Mail sales@sick.com.au

Austria

Phone +43 (0) 2236 62288-0
E-Mail office@sick.at

Belgium/Luxembourg

Phone +32 (0) 2 466 55 66
E-Mail info@sick.be

Brazil

Phone +55 11 3215-4900
E-Mail comercial@sick.com.br

Canada

Phone +1 905.771.1444
E-Mail cs.canada@sick.com

Czech Republic

Phone +420 234 719 500
E-Mail sick@sick.cz

Chile

Phone +56 (2) 2274 7430
E-Mail chile@sick.com

China

Phone +86 20 2882 3600
E-Mail info.china@sick.net.cn

Denmark

Phone +45 45 82 64 00
E-Mail sick@sick.dk

Finland

Phone +358-9-25 15 800
E-Mail sick@sick.fi

France

Phone +33 1 64 62 35 00
E-Mail info@sick.fr

Germany

Phone +49 (0) 2 11 53 010
E-Mail info@sick.de

Greece

Phone +30 210 6825100
E-Mail office@sick.com.gr

Hong Kong

Phone +852 2153 6300
E-Mail ghk@sick.com.hk

Hungary

Phone +36 1 371 2680
E-Mail ertesites@sick.hu

India

Phone +91-22-6119 8900
E-Mail info@sick-india.com

Israel

Phone +972 97110 11
E-Mail info@sick-sensors.com

Italy

Phone +39 02 27 43 41
E-Mail info@sick.it

Japan

Phone +81 3 5309 2112
E-Mail support@sick.jp

Malaysia

Phone +603-8080 7425
E-Mail enquiry.my@sick.com

Mexico

Phone +52 (472) 748 9451
E-Mail mexico@sick.com

Netherlands

Phone +31 (0) 30 229 25 44
E-Mail info@sick.nl

New Zealand

Phone +64 9 415 0459
0800 222 278 – tollfree
E-Mail sales@sick.co.nz

Norway

Phone +47 67 81 50 00
E-Mail sick@sick.no

Poland

Phone +48 22 539 41 00
E-Mail info@sick.pl

Romania

Phone +40 356-17 11 20
E-Mail office@sick.ro

Russia

Phone +7 495 283 09 90
E-Mail info@sick.ru

Singapore

Phone +65 6744 3732
E-Mail sales.gsg@sick.com

Slovakia

Phone +421 482 901 201
E-Mail mail@sick-sk.sk

Slovenia

Phone +386 591 78849
E-Mail office@sick.si

South Africa

Phone +27 10 060 0550
E-Mail info@sickautomation.co.za

South Korea

Phone +82 2 786 6321/4
E-Mail infokorea@sick.com

Spain

Phone +34 93 480 31 00
E-Mail info@sick.es

Sweden

Phone +46 10 110 10 00
E-Mail info@sick.se

Switzerland

Phone +41 41 619 29 39
E-Mail contact@sick.ch

Taiwan

Phone +886-2-2375-6288
E-Mail sales@sick.com.tw

Thailand

Phone +66 2 645 0009
E-Mail marcom.th@sick.com

Turkey

Phone +90 (216) 528 50 00
E-Mail info@sick.com.tr

United Arab Emirates

Phone +971 (0) 4 88 65 878
E-Mail contact@sick.ae

United Kingdom

Phone +44 (0)17278 31121
E-Mail info@sick.co.uk

USA

Phone +1 800.325.7425
E-Mail info@sick.com

Vietnam

Phone +65 6744 3732
E-Mail sales.gsg@sick.com

Detailed addresses and further locations at www.sick.com