

# CLV60x

Fixed mount barcode scanner

**SICK**  
Sensor Intelligence.



---

**Described product**

CLV60x

**Manufacturer**

SICK AG  
Erwin-Sick-Str. 1  
79183 Waldkirch  
Germany

**Legal information**

This work is protected by copyright. Any rights derived from the copyright shall be reserved for SICK AG. Reproduction of this document or parts of this document is only permissible within the limits of the legal determination of Copyright Law. Any modification, abridgment or translation of this document is prohibited without the express written permission of SICK AG.

The trademarks stated in this document are the property of their respective owner.

© SICK AG. All rights reserved.

**Original document**

This document is an original document of SICK AG.



## Contents

<b>1</b>	<b>About this document.....</b>	<b>5</b>
1.1	Information on the operating instructions.....	5
1.2	Explanation of symbols.....	5
1.3	Further information.....	6
<b>2</b>	<b>Safety information.....</b>	<b>7</b>
2.1	Intended use.....	7
2.2	Improper use.....	7
2.3	IP technology.....	7
2.4	Limitation of liability.....	8
2.5	Modifications and conversions.....	8
2.6	Requirements for skilled persons and operating personnel.....	8
2.7	Operational safety and particular hazards.....	9
<b>3</b>	<b>Product description.....</b>	<b>10</b>
3.1	Scope of delivery.....	10
3.2	Type code.....	10
3.3	Type label.....	10
3.4	Status indicators.....	11
3.5	Product features and functions (overview).....	12
3.6	Operating principle.....	12
3.6.1	Object trigger control.....	13
3.7	Reading operation mode.....	13
<b>4</b>	<b>Transport and storage.....</b>	<b>15</b>
4.1	Transport.....	15
4.2	Unpacking.....	15
4.3	Transport inspection.....	15
4.4	Storage.....	15
<b>5</b>	<b>Mounting.....</b>	<b>16</b>
5.1	Overview of mounting procedure.....	16
5.2	Mounting instructions.....	16
5.3	Mounting location.....	16
5.3.1	Basic alignment of the scan line to the bar code.....	16
5.3.2	Reading distance to the bar code and aperture angle $\alpha$ .....	17
5.3.3	Angle alignment of the device.....	17
5.3.4	Avoidance of surface reflections.....	17
5.3.5	Counting direction of the reading angle and the code angle.....	18
5.4	Mounting the device.....	18
<b>6</b>	<b>Electrical installation.....</b>	<b>20</b>
6.1	Safety.....	20
6.1.1	Notes on the electrical installation.....	20
6.2	Prerequisites for safe operation of the device.....	20

6.3	Interface description.....	23
6.4	Wiring interfaces.....	25
6.4.1	Connecting the supply voltage.....	25
6.4.2	Wiring the data interface.....	25
6.4.3	Wiring digital (switching) inputs.....	26
6.4.4	Wiring digital (switching) outputs.....	26
<b>7</b>	<b>Commissioning.....</b>	<b>28</b>
7.1	Overview of the commissioning steps.....	28
7.2	SOPAS ET configuration software.....	28
7.3	Initial Commissioning.....	28
7.4	Fine adjustment and further configuration.....	28
<b>8</b>	<b>Operation.....</b>	<b>30</b>
8.1	Operating options.....	30
<b>9</b>	<b>Maintenance.....</b>	<b>31</b>
9.1	Maintenance.....	31
9.2	Cleaning.....	31
<b>10</b>	<b>Troubleshooting.....</b>	<b>33</b>
10.1	Overview of possible errors and faults.....	33
10.2	Detailed fault analysis.....	33
10.2.1	LEDs on the device.....	33
10.2.2	System information.....	33
10.3	Status log.....	34
10.3.1	Displaying the status log.....	34
10.4	Repairs.....	34
10.5	Returns.....	34
10.6	Disposal.....	34
<b>11</b>	<b>Technical data.....</b>	<b>36</b>
11.1	Features.....	36
11.2	Performance.....	38
11.3	Interfaces.....	38
11.4	Mechanics/electronics.....	38
11.5	Ambient data.....	40
<b>12</b>	<b>Annex.....</b>	<b>42</b>
12.1	Declarations of conformity and certificates.....	42
12.2	Certification according to UL62368.....	42
12.3	Licenses.....	42

# 1 About this document

## 1.1 Information on the operating instructions

These operating instructions provide important information on how to use devices from SICK AG.

Prerequisites for safe work are:

- Compliance with all safety notes and handling instructions supplied.
- Compliance with local work safety regulations and general safety regulations for device applications

The operating instructions are intended to be used by qualified personnel and electrical specialists.



### NOTE

Read these operating instructions carefully before starting any work on the device, in order to familiarize yourself with the device and its functions.

The instructions constitute an integral part of the product and are to be stored in the immediate vicinity of the device so they remain accessible to staff at all times. Should the device be passed on to a third party, these operating instructions should be handed over with it.

These operating instructions do not provide information on operating the machine or system in which the device is integrated. For information about this, refer to the operating instructions of the specific machine.

## 1.2 Explanation of symbols

Warnings and important information in this document are labeled with symbols. The warnings are introduced by signal words that indicate the extent of the danger. These warnings must be observed at all times and care must be taken to avoid accidents, personal injury, and material damage.



### DANGER

... indicates a situation of imminent danger, which will lead to a fatality or serious injuries if not prevented.



### WARNING

... indicates a potentially dangerous situation, which may lead to a fatality or serious injuries if not prevented.



### CAUTION

... indicates a potentially dangerous situation, which may lead to minor/slight injuries if not prevented.



### NOTICE

... indicates a potentially harmful situation, which may lead to material damage if not prevented.



### NOTE

... highlights useful tips and recommendations as well as information for efficient and trouble-free operation.

### 1.3 Further information

---



#### NOTE

Further documentation for the device can be found on the online product page at:

- [www.sick.com/CLV60x](http://www.sick.com/CLV60x)

The following information is available for download there:

- Model-specific online data sheets for device variants, containing technical data, dimensional drawing, and specification diagrams
  - EU declaration of conformity for the product family
  - Dimensional drawings and 3D CAD dimension models in various electronic formats
  - These operating instructions, available in English and German, and in other languages if necessary
  - Other publications related to the devices described here
  - Publications dealing with accessories
-

## 2 Safety information

### 2.1 Intended use

The CLV60x fixed mount barcode scanner is an intelligent, opto-electronic ID sensor and is used for automatic, fixed identification and decoding of bar codes on moving or stationary objects. The data content of the decoded bar codes is transmitted via the device to a higher-level control (PLC) or an industrial computer for coordinating processing.



#### NOTE

The bar codes to be read must comply at least with quality level C in accordance with ISO/IEC 15416.

The product variants with connecting cable and USB plug are not designed for rough industrial environments with strong electromagnetic interference. During installation, make sure that no sources of interference are in the direct vicinity of the product. Use the USB devices in offices or in applications with similar ambient conditions (e.g. libraries or laboratories).

SICK AG assumes no liability for losses or damage arising from the use of the product, either directly or indirectly. This applies in particular to use of the product that does not conform to its intended purpose and is not described in this documentation.

### 2.2 Improper use

Any use outside of the stated areas, in particular use outside of the technical specifications and the requirements for intended use, will be deemed to be incorrect use.

- The device does not constitute a safety component in accordance with the respective applicable safety standards for machines.
- The device must not be used in explosion-hazardous areas, in corrosive environments or under extreme environmental conditions.
- Any use of accessories not specifically approved by SICK AG is at your own risk.



#### WARNING

##### Danger due to improper use!

Any improper use can result in dangerous situations.

Therefore, observe the following information:

- Device should be used only in accordance with its intended use.
- All information in these operating instructions must be strictly observed.

### 2.3 IP technology



#### NOTE

SICK uses standard IP technology in its products. The emphasis is placed on availability of products and services.

SICK always assumes the following prerequisites:

- The customer ensures the integrity and confidentiality of the data and rights affected by its own use of the aforementioned products.
- In all cases, the customer implements the appropriate security measures, such as network separation, firewalls, virus protection, and patch management.

### 2.4 Limitation of liability

Applicable standards and regulations, the latest state of technological development, and our many years of knowledge and experience have all been taken into account when assembling the data and information contained in these operating instructions. The manufacturer accepts no liability for damage caused by:

- Failing to observe the operating instructions
- Incorrect use
- Use by untrained personnel
- Unauthorized conversions
- Technical modifications
- Use of unauthorized spare parts, consumables, and accessories

With special variants, where optional extras have been ordered, or owing to the latest technical changes, the actual scope of delivery may vary from the features and illustrations shown here.

### 2.5 Modifications and conversions



#### NOTICE

Modifications and conversions to the device may result in unforeseeable dangers.

---

Interrupting or modifying the device or SICK software will invalidate any warranty claims against SICK AG. This applies in particular to opening the housing, even as part of mounting and electrical installation.

### 2.6 Requirements for skilled persons and operating personnel



#### WARNING

**Risk of injury due to insufficient training.**

Improper handling of the device may result in considerable personal injury and material damage.

- All work must only ever be carried out by the stipulated persons.
- 

The operating instructions state the following qualification requirements for the various areas of work:

- **Instructed personnel** have been briefed by the operator about the tasks assigned to them and about potential dangers arising from improper action.
- **Skilled personnel** have the specialist training, skills, and experience, as well as knowledge of the relevant regulations, to be able to perform tasks delegated to them and to detect and avoid any potential dangers independently.
- **Electricians** have the specialist training, skills, and experience, as well as knowledge of the relevant standards and provisions to be able to carry out work on electrical systems and to detect and avoid any potential dangers independently. In Germany, electricians must meet the specifications of the BGV A3 Work Safety Regulations (e.g. Master Electrician). Other relevant regulations applicable in other countries must be observed.

The following qualifications are required for various activities:



Table 1: Activities and technical requirements

Activities	Qualification
Mounting, maintenance	<ul style="list-style-type: none"> <li>■ Basic practical technical training</li> <li>■ Knowledge of the current safety regulations in the workplace</li> </ul>
Electrical installation, device replacement	<ul style="list-style-type: none"> <li>■ Practical electrical training</li> <li>■ Knowledge of current electrical safety regulations</li> <li>■ Knowledge of the operation and control of the devices in their particular application</li> </ul>
Commissioning, configuration	<ul style="list-style-type: none"> <li>■ Basic knowledge of the Windows™ operating system in use</li> <li>■ Basic knowledge of the design and setup of the described connections and interfaces</li> <li>■ Basic knowledge of data transmission</li> <li>■ Basic knowledge of bar code technology</li> </ul>
Operation of the device for the particular application	<ul style="list-style-type: none"> <li>■ Knowledge of the operation and control of the devices in their particular application</li> <li>■ Knowledge of the software and hardware environment for the particular application</li> </ul>

## 2.7 Operational safety and particular hazards

Please observe the safety notes and the warnings listed here and in other chapters of these operating instructions to reduce the possibility of risks to health and avoid dangerous situations.

The product is fitted with LEDs of the risk group 0. The accessible radiation from these LEDs does not pose a danger to the eyes or skin.



### WARNING

#### Electrical voltage!

Electrical voltage can cause severe injury or death.

- Work on electrical systems must only be performed by qualified electricians.
- The power supply must be disconnected when attaching and detaching electrical connections.
- The sensor must only be connected to a voltage source as set out in the requirements in the operating instructions.
- National and regional regulations must be complied with.
- Safety requirements relating to work on electrical systems must be complied with.



### WARNING

#### Dangerous equipotential bonding currents!

Improper grounding can lead to dangerous equipotential bonding currents, which may in turn lead to dangerous voltages on metallic surfaces, such as the housing. Electrical voltage can cause severe injury or death.

- Work on electrical systems must only be performed by qualified electricians.
- Follow the notes in the operating instructions.
- Install the grounding for the product and the system in accordance with national and regional regulations.

## 3 Product description

### 3.1 Scope of delivery

The delivery of the device includes the following components:

Table 2: Scope of delivery

Item	Component	Comments
1	Device in the version ordered	Depending on version
1	Printed safety notes	-

### 3.2 Type code

The devices of the CLV60x product family are arranged according to the following type code:

CLV	xxx	-	a	b	c	d	e
1	2		3	4	5	6	7

Table 3: Type code

Position	Description	Characteristic
1	Device name	V-scanner code reader
2	Device type	601: Standard range 602: Long range
3	Version	0: Reading window at front 1: Reading window on side (angle 103°)
4	Connection type	A: With open cable end U: USB-A male connector D: D-SUB male connector, 9-pin
5	Length of cable	1: Cable: approx. 1.5 m 2: Cable: approx. 2.0 m
6	Host interface	0: RS-232 1: USB
7	Supply voltage	0: DC 5 V ±10%



#### NOTE

Not all combinations are possible according to the type code. The available device variants can be found online at:

- [www.sick.com/CLV60x](http://www.sick.com/CLV60x)

### 3.3 Type label

The type label gives information for identification of the device.

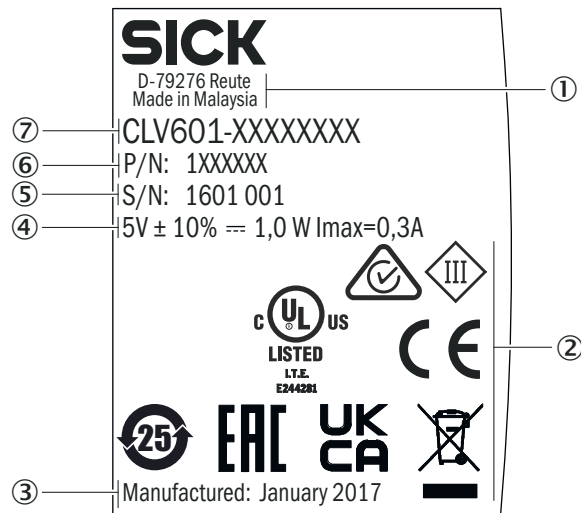

Figure 1: Type label (example)

- ① Manufacturer's address/country of production
- ② Approval marks and test symbols
- ③ Production date
- ④ Technical data
- ⑤ Serial number
- ⑥ Material number
- ⑦ Type code

### 3.4 Status indicators

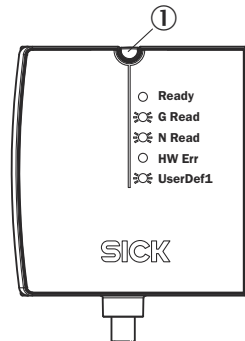

Figure 2: Status indicators

- ① Status LED

Table 4: Display behavior of the LED

Color of LED	Status	Status
-	OFF	Device without supply voltage
		After switching on: Parameter download for the device
Blue	ON	After switching on or after firmware download: Self-test successful, device ready for operation
Green	Lights up briefly	Reading successful (Good Read)
Red	Lights up briefly	Reading unsuccessful (No Read)
Red	ON	Hardware error (HW Err)

Color of LED	Status	Status
Light blue	–	UserDef1 (reserved)
Red Blue	Flashes alternately in both colors	Firmware download
Red	ON	Firmware download: Error: Completion not successful

### 3.5 Product features and functions (overview)

Table 5: Overview of product features and functions of the device

Product feature/function	Characteristic
Security and ease of use	<ul style="list-style-type: none"> <li>• Rugged, compact metal housing</li> <li>• Automatic self-test at system start</li> <li>• Diagnostic tools for system setup and (remote) system monitoring</li> <li>• Configurable output of reading diagnostic data</li> <li>• Operating data polling, in case of error, issue of error code if required</li> <li>• Test string function (heartbeat) can be activated to signal that the device is ready for operation</li> <li>• Password-protected configuration mode via SOPAS ET</li> <li>• Future-oriented due to firmware update (FLASH PROM) via data interface</li> <li>• Future-oriented SOPAS ET configuration software</li> <li>• Low power consumption</li> </ul>
Convenient operation/configuration	<ul style="list-style-type: none"> <li>• Configuration via SOPAS ET configuration software (online/offline) or commands</li> <li>• LED status indicators</li> <li>• Beeper for actuating the device function can be switched off</li> </ul>
Read operation modes	<ul style="list-style-type: none"> <li>• Start/stop operation (one bar code bearing object per read cycle)</li> </ul>
Read cycle	<ul style="list-style-type: none"> <li>• Pulse sources for start: Digital inputs, data interface (command), auto pulse, free</li> <li>• Pulse sources for stop: Read cycle source, digital inputs, data interface (command), timer, condition</li> </ul>
Bar code evaluation	<ul style="list-style-type: none"> <li>• All current 1D bar code types</li> <li>• No. of codes per reading interval: 1 ... 15 (auto-discriminating)</li> </ul>
Data processing	<ul style="list-style-type: none"> <li>• Influencing the output of the reading data by event-dependent evaluation conditions</li> </ul>
Data Communication	<ul style="list-style-type: none"> <li>• Host interface: A data output format can be configured for the reading result, can be switched to various physical interfaces, parallel operation possible</li> <li>• AUX interface: Fixed data output format</li> </ul>

### 3.6 Operating principle

The CLV60x CMOS bar code reader detects bar codes in an illuminated scanning field (scan line). The length of the scan line which can be used for evaluation (reading field height) depends on the reading distance as a result of the V-shaped light emission.

The light pattern reflected from the bar code is recorded, processed, and decoded. External sensors deliver information about the read cycle to control this process.

The read results are output to the device data interfaces and forwarded to a host/PC.

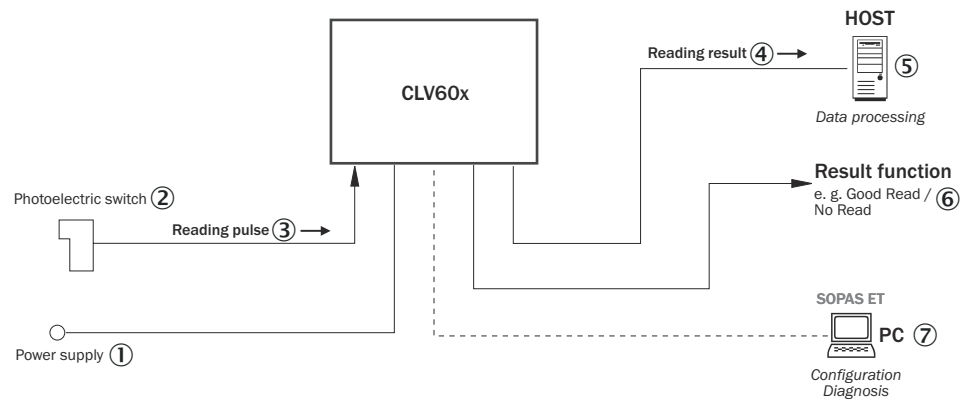

Figure 3: Operating principle of the CLV60x

- ① Voltage supply
- ② Photoelectric sensor
- ③ Read cycle
- ④ Read result
- ⑤ Host/PC: Data processing
- ⑥ Read function, e.g. read successful / read unsuccessful
- ⑦ SOPAS ET PC software: Configuration, diagnosis

Detailed wiring of the device and the connections to the host/PC and the external sensors are described in chapter Electrical installation.

### 3.6.1 Object trigger control

The device needs a suitable external signal (trigger source) for reporting an object in the reading field in order to start an object-related read process. As standard, the start signal is issued via an external read-cycle sensor (e.g. photoelectric sensor). As soon as an object has passed the read-cycle sensor, a time window (“reading interval”) is opened in the device for the read process.

Alternatively, a command triggers the read process via a data interface or the SICK SENSOR network. In auto pulse mode, the device internally generates the reading interval itself with an adjustable clock ratio.

The read cycle can be ended in several ways. For example, external triggering by the read cycle source or a command, or internally by a timer or a evaluation condition to be fulfilled.



**NOTE**

The SOPAS ET configuration software can be used to configure the trigger source.

### 3.7 Reading operation mode

In “start/stop” operation, there is only ever one object in the reading field during the reading process, i.e., all read codes can be clearly assigned to the object. As standard, starting and stopping of the reading process are controlled by one or two read cycle sensor(s) at the start and end of the reading field.

In this case, the distance between the read cycle sensors determines the size of the reading field. The reading process can alternatively be controlled with command strings via the data interface.

The output of the read results is either carried out at the end of the read cycle (the rear edge of the object has left the end of the reading field) or even during the read cycle if certain configurable conditions are met.

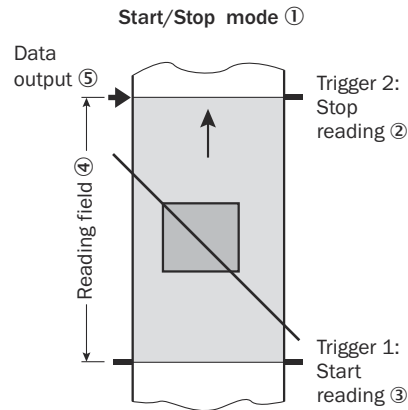

Figure 4: Start/stop operating mode of the device in stand-alone operation

- ① Start/stop operation
- ② Trigger 2: Stop reading
- ③ Trigger 1: Start reading
- ④ Reading field
- ⑤ Data output



#### NOTE

The SOPAS ET configuration software can be used to configure the reading operation mode.

---

## 4 Transport and storage

### 4.1 Transport

For your own safety, please read and observe the following notes:



#### NOTICE

##### Damage to the product due to improper transport.

- The device must be packaged for transport with protection against shock and damp.
- Recommendation: Use the original packaging as it provides the best protection.
- Transport should be performed by trained specialist staff only.
- The utmost care and attention is required at all times during unloading and transportation on company premises.
- Note the symbols on the packaging.
- Do not remove packaging until immediately before you start mounting.

### 4.2 Unpacking

- To protect the device against condensation, allow it to equilibrate with the ambient temperature before unpacking if necessary.
- Handle the device with care and protect it from mechanical damage.

### 4.3 Transport inspection

Immediately upon receipt in Goods-in, check the delivery for completeness and for any damage that may have occurred in transit. In the case of transit damage that is visible externally, proceed as follows:

- Do not accept the delivery or only do so conditionally.
- Note the scope of damage on the transport documents or on the transport company's delivery note.
- File a complaint.



#### NOTE

Complaints regarding defects should be filed as soon as these are detected. Damage claims are only valid before the applicable complaint deadlines.

### 4.4 Storage

Store the device under the following conditions:

- Recommendation: Use the original packaging.
- Electrical connections are provided with protective caps and plugs (as they are on delivery).
- Do not store outdoors.
- Store in a dry area that is protected from dust.
- So that any residual damp can evaporate, do not package in airtight containers.
- Do not expose to any aggressive substances.
- Protect from sunlight.
- Avoid mechanical shocks.
- Storage temperature: see "Technical data", page 36.
- Relative humidity: see "Technical data", page 36.
- For storage periods of longer than 3 months, check the general condition of all components and packaging on a regular basis.

## 5 Mounting

### 5.1 Overview of mounting procedure

- Selecting and preparing the mounting location.
- Mounting the device.
- Align device towards object with bar code.
- Connect device to data cable and supply cable.
- Adjust the device.



---

**WARNING****Risk of injury due to damage to the device**

For reasons of safety, a device which is visibly damaged must not be operated or must be immediately taken out of operation. Damage includes, for example:

- Housing: Cracked or broken
  - Reading window lens: Cracked or broken
  - Device with connector: Over-rotation of the connector, cracks, or being torn from the housing
  - Device with fixed cable: Damage to the cable outlet or cable itself
- 

### 5.2 Mounting instructions

- Observe the technical data of the device when selecting an installation location.
- For typical space requirements for the device, see type-specific dimensional drawing and reading field diagram.
- To prevent condensation, avoid exposing the device to rapid changes in temperature.
- Protect the device from direct sunlight.
- The device must only be mounted using the pairs of blind tapped holes provided for this purpose.
- Shock and vibration-free mounting.

**Equipment required****NOTE**

The screws are for mounting the device on mounting equipment (bracket) supplied by the user. Screw length is dependent on the mounting base (wall thickness of the bracket).

---

- Tool and tape measure

### 5.3 Mounting location

When selecting the mounting location, the following factors are significant:

- ▶ Basic allocation of the scan line to the bar code
- ▶ Reading distance to the bar code and aperture angle  $\alpha$
- ▶ Angle alignment of the device
- ▶ Avoidance of surface reflections
- ▶ Count direction of the reading angle (position of the bar code along the scan line)

#### 5.3.1 Basic alignment of the scan line to the bar code

Please note that the complete red illumination line does not correspond to the reading field of the device. About 7.5%, seen from both ends, cannot be read.



### 5.3.2 Reading distance to the bar code and aperture angle $\alpha$

The maximum distance from the viewing window of the device to the bar code may not exceed the limit values for the device. Because of the V-shaped deflection of the beams, the usable length of the scan line for evaluation (reading field height) depends on the reading distance.

The specification diagrams show the height of the reading field as a function of the reading distance at different resolutions (module widths), see "Technical data", page 36.

### 5.3.3 Angle alignment of the device

The optimum alignment of the device is achieved when the scan line crosses the stripes of the bar code as close to a right angle as possible (tilt and inclination). Possible reading angles that can arise between scan line and bar code at all three levels in the area must be taken into account.

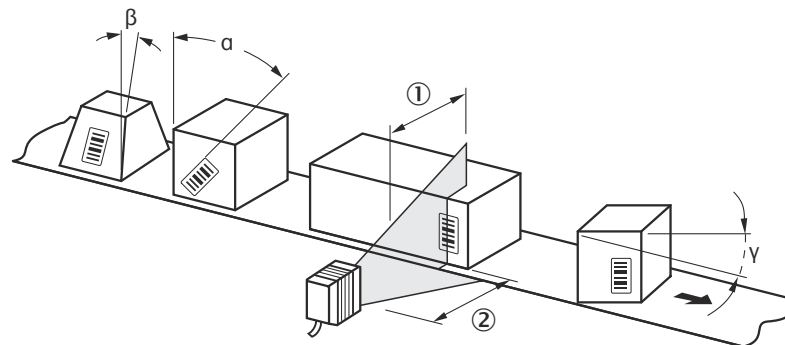

Figure 5: Line scanner: Read angle occurring between scanning line and bar code

- ① Depth of field
- ② Reading distance



#### NOTE

The specified maximum values can only be achieved if conditions are optimal. The actual maximum depends on the module width, code type, print contrast, ambient light, distance and scanning frequency.

Table 6: Permitted read angle between scanning line and bar code

Angle	CLV601	CLV602
Tilt $\alpha$	$\pm 5^\circ$ (with code resolution $\geq 0.125$ mm) $\pm 10^\circ$ (with code resolution $\geq 0.15$ mm) $\pm 15^\circ$ (with code resolution $\geq 0.2$ mm) $\pm 25^\circ$ (with code resolution $\geq 0.35$ mm)	$\pm 5^\circ$ (with code resolution $\geq 0.20$ mm) $\pm 10^\circ$ (with code resolution $\geq 0.25$ mm) $\pm 15^\circ$ (with code resolution $\geq 0.35$ mm) $\pm 25^\circ$ (with code resolution $\geq 0.50$ mm)
Pitch $\beta$	$\pm 6^\circ$ (with code resolution $\geq 0.2$ mm) $\pm 15^\circ$ (with code resolution $\geq 0.5$ mm)	$\pm 6^\circ$ (with code resolution $\geq 0.2$ mm) $\pm 15^\circ$ (with code resolution $\geq 0.5$ mm)
Skew $\gamma$	$\pm 20^\circ$ (with code resolution $\geq 0.2$ mm) $\pm 30^\circ$ (with code resolution $\geq 0.5$ mm)	$\pm 20^\circ$ (with code resolution $\geq 0.2$ mm) $\pm 30^\circ$ (with code resolution $\geq 0.5$ mm)

### 5.3.4 Avoidance of surface reflections

If the light of the scan line(s) hits the surface of the bar code precisely vertically, this may cause interference when the light reflected back is received. To prevent this effect, the device must be mounted so that the light emitted is tilted relative to the vertical.



**NOTE**

Optimal results are achieved when the scan line is tilted about 13° relative to the vertical. The version with a side reading window therefore features a light emission angle of 103°.

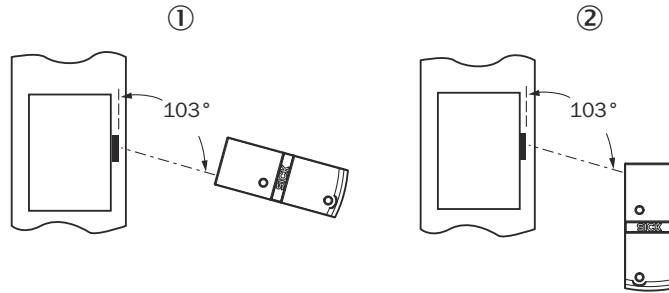

Figure 6: Avoiding surface reflections: Angle between light emitted and bar code (tilting away from vertical)

- ① Product variant with reading window at the front (top view)
- ② Product variant with reading window at the side (top view)

**5.3.5 Counting direction of the reading angle and the code angle**

The device can scan and decode several bar codes at each reading.

At the same time, the location-specific reading diagnostics data are determined for each of them:

- The reading angle, starting from the reading window, at which the device detects the bar code center on the red scanning line of the deflected scanning beam can be output as an RA (reading angle) value.

By determining the RA value, identical bar codes (code type, code length, and data content) can be separated, and the bar code data assigned based on their position on the object. 1 RA corresponds to about 0.71° (50 RAs correspond to 35.4°, 100 RAs correspond to an aperture angle of 70.8°).

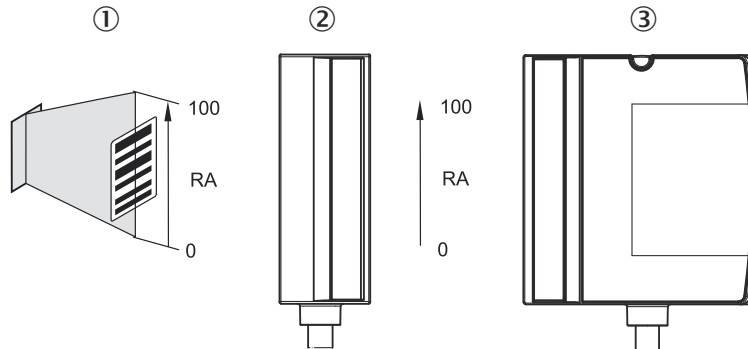

Figure 7: Counting direction and RA value calculation

- ① Counting direction (aperture angle in reading direction)
- ② Product variant with reading window at the front
- ③ Product variant with reading window at the side

**5.4 Mounting the device**

**NOTICE****Risk of damaging the device!**

Observe the maximum screw-in depth of the blind hole thread. Longer screws than specified damage the device.

- ▶ Use screws of suitable length.

1. Prepare the base for mounting the device bracket.
2. Place the object with the bar code in the view of the device in the position where the reading is to take place (conveyor static).
3. Align device with the bar code by sight. When doing so, be aware of the following:
  - Make sure that the device side with the reading window is aligned as near as possible to parallel to the bar code surface.
  - During reading, note the reading angle that occurs [see "Angle alignment of the device", page 17](#).
  - If the position of the bar code within the scanning line is relevant for the evaluation, bear in mind the count direction of the code position [see "Counting direction of the reading angle and the code angle", page 18](#).
4. Mount the device bracket onto the base.
5. Tighten screws through the bracket into the blind tapped holes of the device and slightly tighten.

### 6 Electrical installation

#### 6.1 Safety

##### 6.1.1 Notes on the electrical installation

- **The electrical installation must only be performed by electrically qualified personnel.**
- **Standard safety requirements must be met when working on electrical systems.**
- Only switch on the supply voltage for the device when the connection tasks have been completed and the wiring has been thoroughly checked.
- When using extension cables with open ends, ensure that bare wire ends do not come into contact with each other (risk of short-circuit when supply voltage is switched on!). Wires must be appropriately insulated from each other.
- Wire cross-sections in the supply cable from the customer's power system must be selected in accordance with the applicable standards. When this is being done in Germany, observe the following standards: DIN VDE 0100 (Part 430) and DIN VDE 0298 (Part 4) and/or DIN VDE 0891 (Part 1).
- Electrical circuits connected to the device must be configured as SELV circuits (SELV = safety extra-low voltage) in accordance with IEC 60950-1 or ES1 in accordance with IEC 62368-1.



#### NOTE

##### Layout of data cables

- Use screened data cables with twisted-pair wires.
  - Implement the screening design correctly and completely.
  - To avoid interference, e.g. from switching power supplies, motors, clocked drives, and contactors, always use cables and layouts that are suitable for EMC.
  - Do not lay cables over long distances in parallel with power supply cables and motor cables in cable channels.
- 

#### 6.2 Prerequisites for safe operation of the device



#### WARNING

##### Risk of injury and damage caused by electrical current!

As a result of equipotential bonding currents between the device and other grounded devices in the system, faulty grounding of the device can give rise to the following dangers and faults:

- Metal housings are vulnerable to dangerous currents.
- Devices will behave incorrectly or be destroyed.
- Cable shielding will be damaged by overheating and cause cable fires.

##### Remedial measures

- Only skilled electricians should be permitted to carry out work on the electrical system.
  - If the cable insulation is damaged, disconnect the voltage supply immediately and have the damage repaired.
  - Ensure that the ground potential is the same at all grounding points.
  - Where local conditions do not meet the requirements for a safe earthing method, take appropriate measures (e.g., ensuring low-impedance and current-carrying equipotential bonding).
-

The device is connected to the peripheral devices (voltage supply, any local pulse sensor(s), system controller) via shielded cables. The cable shield – for the data cable, for example – rests against the metal housing of the device. The device can be grounded through the cable shield or through a blind tapped hole in the housing, for example.

If the peripheral devices have metal housings and if the cable shields also lie on their housings, it is assumed that all devices involved in the installation have the **same ground potential**.

This is achieved by complying with the following conditions:

- Mounting the devices on conductive metal surfaces
- Correctly grounding the devices and metal surfaces in the system
- If necessary: low-impedance and current-carrying equipotential bonding between areas with different ground potentials

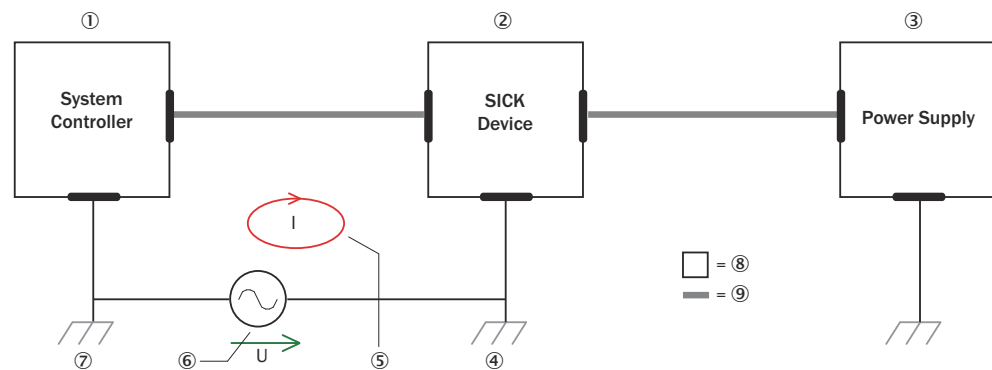

Figure 8: Example: Occurrence of equipotential bonding currents in the system configuration

- ① System controller
- ② Device
- ③ Voltage supply
- ④ Grounding point 2
- ⑤ Closed current loop with equalizing currents via cable shield
- ⑥ Ground potential difference
- ⑦ Grounding point 1
- ⑧ Metal housing
- ⑨ Shielded electrical cable

If these conditions are not fulfilled, equipotential bonding currents can flow along the cable shielding between the devices due to differing ground potentials and cause the hazards specified. This is, for example, possible in cases where there are devices within a widely distributed system covering several buildings.

#### Remedial measures

The most common solution to prevent equipotential bonding currents on cable shields is to ensure low-impedance and current-carrying equipotential bonding. If this is not possible, the following solution approaches serve as a suggestion.



#### NOTICE

We expressly advise against opening up the cable shields. This would mean that the EMC limit values can no longer be complied with and that the safe operation of the device data interfaces can no longer be guaranteed.

#### Measures for widely distributed system installations

On widely distributed system installations with correspondingly large potential differences, the setting up of local islands and connecting them using commercially available **electro-optical signal isolators** is recommended. This measure achieves a high degree of resistance to electromagnetic interference.

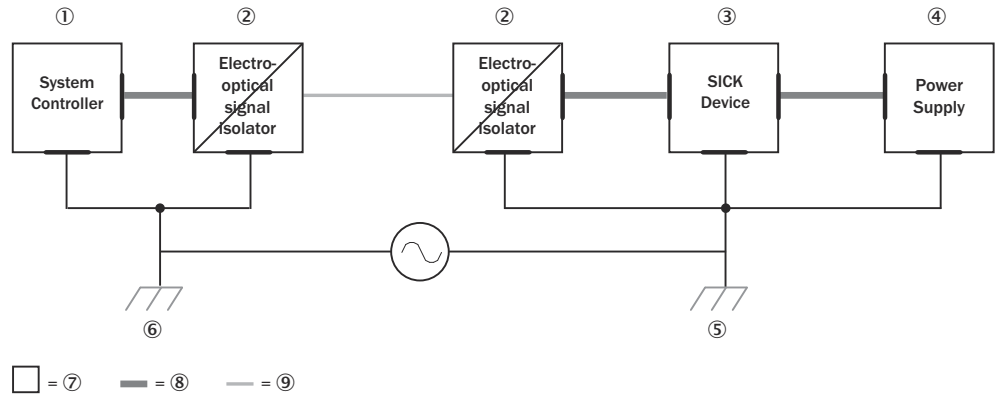

Figure 9: Example: Prevention of equipotential bonding currents in the system configuration by the use of electro-optical signal isolators

- ① System controller
- ② Electro-optical signal isolator
- ③ Device
- ④ Voltage supply
- ⑤ Grounding point 2
- ⑥ Grounding point 1
- ⑦ Metal housing
- ⑧ Shielded electrical cable
- ⑨ Optical fiber

The use of electro-optical signal isolators between the islands isolates the ground loop. Within the islands, a stable equipotential bonding prevents equalizing currents on the cable shields.

**Measures for small system installations**

For smaller installations with only slight potential differences, insulated mounting of the device and of peripheral devices may be a sufficient solution.

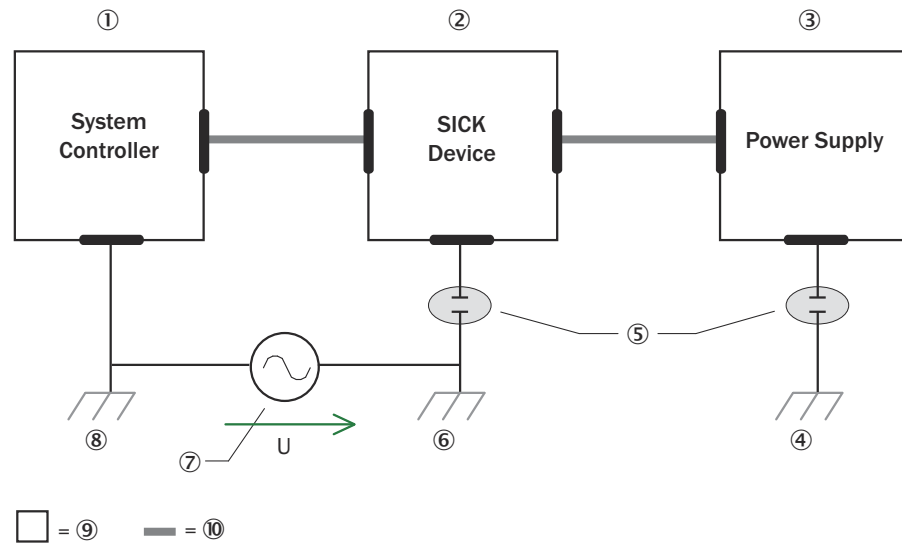

Figure 10: Example: Prevention of equipotential bonding currents in the system configuration by the insulated mounting of the device

- ① System controller
- ② Device
- ③ Voltage supply
- ④ Grounding point 3
- ⑤ Insulated mounting
- ⑥ Grounding point 2
- ⑦ Grounding potential difference
- ⑧ Grounding point 1
- ⑨ Metal housing
- ⑩ Shielded electrical cable

Even in the event of large differences in the ground potential, ground loops are effectively prevented. As a result, equalizing currents can no longer flow via the cable shields and metal housing.



#### NOTICE

The voltage supply for the device and the connected peripheral devices must also guarantee the required level of insulation.

Under certain circumstances, a tangible potential can develop between the insulated metal housings and the local ground potential.

## 6.3 Interface description

### Connection of devices with cable and RS-232 male connector

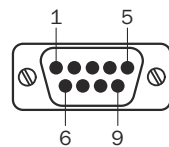

Figure 11: Male connector, D-Sub, 9-pin

Table 7: Pin assignment on 9-pin D-Sub-HD male cable connector

Pin on D-sub connector	Wire color	Signal	Function
1	White	In1	Digital input (switching)
2	Red	RxD (HOST)	HOST interface (receiver)
3	Green	TxD (HOST)	HOST interface (sender)
4	Black	Out1	Digital output 1 (switching)
5	Gray & Blue	GND	Ground
6	Violet	Out2	Digital output 2 (switching)
7	Yellow	RxD (AUX)	AUX interface (receiver)
8	Orange	TxD (AUX)	AUX interface (sender)
9	Pink & Brown	+5V	Supply voltage

### Connection of devices with cable and USB male connector

Devices with cable and USB-a\_connector can be operated in the Keyboard wedge (HID), Virtual COM port (CDC) and SOPAS (vendor-specific) operating modes. Switching over is not necessary since this happens automatically via USB Composite.

#### Properties of different operating modes:

- **USB-HID (Human Interface Device):** Keyboard connector, scanner is operated as a generic USB keyboard.
- **Virtual COM Port:** Scanner is operated via an emulator as a serial RS-232 device.
- **SOPAS-USB:** Alternative to the virtual COM port

Table 8: Pin assignment on 4-pin USB A male cable connector

Pin	Signal	Function
1	+5V	Supply voltage
2	Data-	Data input
3	Data+	Data output
4	GND	Ground

Before connecting for the first time, install the USB COM port driver (available at [www.sick.com/CLV60x](http://www.sick.com/CLV60x)). A standard virtual COM port driver is integrated from Windows 10. The SOPAS ET software must be installed on the host computer to use SOPAS USB.



#### NOTE

- We recommend connecting the CLV601-USB directly to the host machine. A USB hub should be avoided.
- The USB Virtual COM is defined as the host interface. This USB class “Communication Device Class” is one of the commonly defined class codes. The Windows-based driver “CLV60x\_USB\_COM\_Driver\_setup\_v1.34.0\_2019-05-29\_setup.exe” is strictly recommended. The driver is available on [www.sick.com/CLV60x](http://www.sick.com/CLV60x).

#### This driver has some advantages against the Windows default VCOM driver:

- Higher robustness regarding EMC interference.
- Supports Clear-Feature request to the device. This request is a prerequisite for automatic error handling of the device driver. Therefore, the device driver can be used with active error handling. Thus, random EMC disturbances do not necessarily necessitate the re-plug of the device, and communication can continue.



- Static COM port feature. If the device does a power cycle for example due to an EMC interruption, the opened COM port doesn't need a re-open process. In this case, the communication can continue after device rebooting without any additional COM port handling.
- Fixed COM port assignment for COM4 or alternatively for COM8. If both COM ports are already used by the system Windows it will be given any other COM port number that is free. More information is available in the document from Theyson "COM\_Port\_DeviceCoInstaller\_Manual.pdf". If the default COM ports (4 and 8) should be changed because of the application the following file can be modified: "C:\Windows\System32\ComPortCoInst.ini".

## 6.4 Wiring interfaces

### 6.4.1 Connecting the supply voltage

The device must be connected to a power supply unit with the following properties:

- Supply voltage 5 V DC  $\pm$  10% (stabilized safety extra-low voltage SELV (EN 60950-1) and LPS (IEC 60950-1) or ES-1 and PS2 (EN 62368-1) as per currently valid standards)
- Voltage source with at least 1.5 W power

When configuring the voltage supply, the switch-on current of the device must be taken into consideration. The initial power consumption depends on the input capacitors of the device. The input capacitor is about 50  $\mu$ F for the RS232 variant. If, for example, 10 devices with a voltage supply are used, that means:

$$P_{\max} = 10 * 1.5 \text{ W} = 15 \text{ W}$$

$$\text{Sum of capacitors} = 10 * 50 \mu\text{F} = 500 \mu\text{F}$$

The voltage supply should be able to process 500  $\mu$ F load for commissioning.

### 6.4.2 Wiring the data interface

#### Wiring the serial data interface

The maximum data transmission rate for the serial interface depends on the length of cable and on the type of interface. The following recommendations apply:

Table 9: Data transmission rates

Interface type	Data transmission rate	Distance to the target computer (host)
RS-232	Up to 19.2 kBd 38.4 kBd ... 57.6 kBd 115.2 kBd ... 500 kBd	Max. 10 m Max. 3 m Max. 2 m



#### NOTICE

##### Risk of damage to the internal interface modules!

If the serial data interfaces are wired incorrectly, then electronic components in the device could get damaged.

- Observe the information on wiring.
- Carefully check the wiring prior to switching on the device.

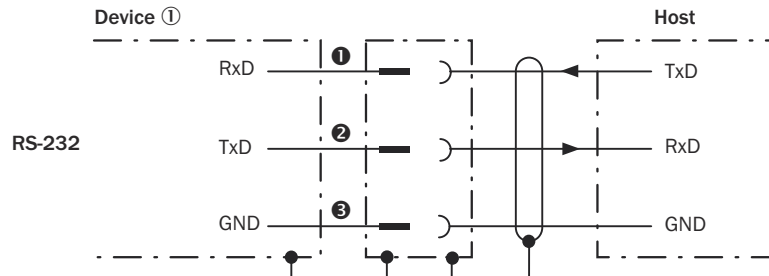

Figure 12: Internal circuitry for RS-232 data interface

- ① Device
- ❶...❸ Pin assignment: See RS-232 pin assignment for the respective device

### 6.4.3 Wiring digital (switching) inputs

#### Digital inputs on the device

The digital inputs can be used to start and/or end the read cycle.

The number of digital inputs available at the connections will vary depending on the device, see "Interface description", page 23.

Table 10: Characteristic data for the digital inputs

<b>Switching behavior</b>	Power at the input starts the internal reading interval of the device [default: active high, debounce: min. 1 ms, max. 10000 ms, standard 10 ms]
<b>Properties</b>	Opto-decoupled Reverse polarity protected
<b>Electrical values</b>	The electrical values are identical for all digital inputs. Digital low: $V_{in} < 0.8\text{ V}$ Digital high: $V_{in} > 3\text{ V}$

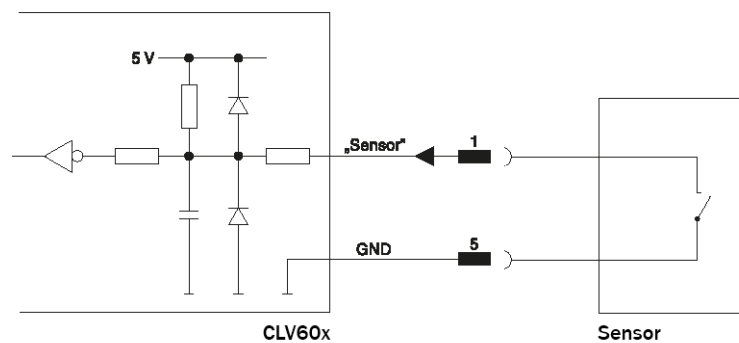

Figure 13: Wiring of a digital input with external NPN sensor

### 6.4.4 Wiring digital (switching) outputs

#### Digital outputs on the device

The digital outputs can be allocated independently of each other with various functions for event status indication. If the allocated event occurs in the read process, then the corresponding digital output is live after the end of the clock reading pulse for the selected pulse duration.

Table 11: Characteristic data for the digital outputs

<b>Switching behavior</b>	NPN switching to supply voltage $V_S$
---------------------------	---------------------------------------

<b>Properties</b>	Short-circuit protected Temperature protected Not electrically isolated from $V_S$
<b>Electrical values</b>	The electrical values are identical for all digital outputs. $5\text{ V} \leq V_{\text{out}} \leq 30\text{ V}$ $I_{\text{out}} \leq 50\text{ mA}$ Voltage peak at maximum switching current $\leq 0.8\text{ V}$ $(U_S - 1.5\text{ V}) \leq U_a \leq U_S$ at $I_a \leq 50\text{ mA}$

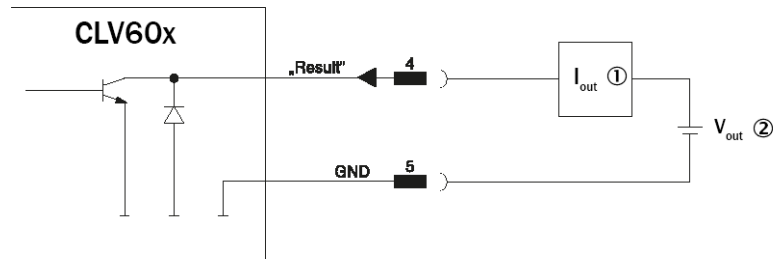

Figure 14: Wiring a switching output



#### NOTE

Capacitive loads on the digital outputs have an effect on the switch-on and switch-off behavior. The maximum capacity of 100 mF and an external load resistance of maximum 10 k $\Omega$  is a limit value.

1. Connect the digital outputs according to the application.
2. For the thorough check of the switching functions, use a high resistance digital voltmeter and wire the digital outputs with a load. This prevents the display of incorrect voltage values/output states.

## 7 Commissioning

### 7.1 Overview of the commissioning steps

- Commissioning of the device with factory default
- Installing the SOPAS ET configuration software
- Connection of the device to PC/notebook with the SOPAS ET configuration software
- Adjustment and configuration of the device to optimize functionality
- Test of the device for correct functionality in read operation

### 7.2 SOPAS ET configuration software

The SOPAS-ET configuration software can be used to adapt the device to the reading situation on site. The configuration data is stored and archived as a parameter set (project file) on the PC.

### 7.3 Initial Commissioning

The device is adjusted to the reading situation on site using the SOPAS ET configuration software. The starting point for this is the default factory settings, which can be adjusted to optimize the device. In order to do this, the SOPAS ET configuration software is used to create an application-specific parameter set, which can be loaded permanently into the device and saved and archived as a project file (SOPAS file with configuration data) on the PC.

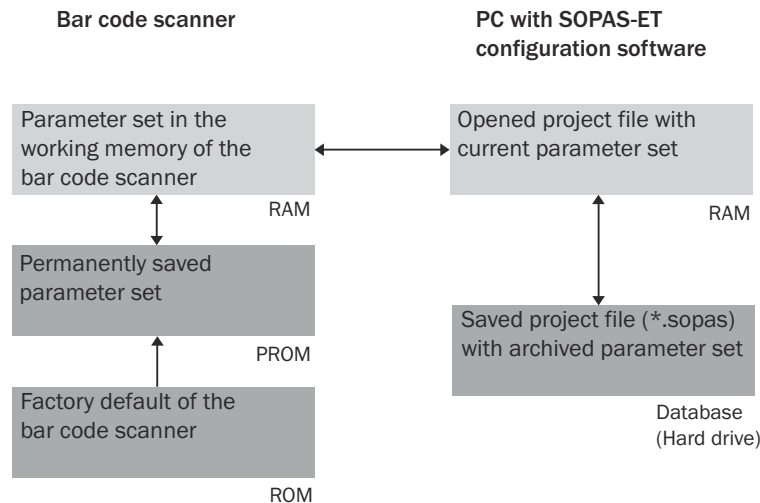

Figure 15: Saving the parameter set and configuration with SOPAS ET

### 7.4 Fine adjustment and further configuration



#### NOTE

The additional settings and the fine adjustment depend on the respective application situation.

#### User level, parameter download for device

The user is automatically logged into the device in the “Authorized customer” level and can change parameters which are immediately transmitted to the device (default setting).

### Configuration via Quickstart

The Quickstart tab offers an overview of the most important parameters and enables quick evaluation of code content. Among others, functions such as “Evaluation window,” “Percentage evaluation,” “Code configuration,” and “Adjusting mode” are available via the Quickstart.

### Evaluation window

The evaluation window shows the code content, the object index, the code type, the code security, and the device number of the reading device.

### Percentage evaluation

Percentage evaluation permanently assesses the quality of the reading. Bar codes are not assessed. Here, the bar codes must not be subjected to any conveying movement. The device performs 100 scans in each case and evaluates the reading quality. The device continuously emits read results every 2 s via the AUX interface, together with the read diagnostic data. A timer starts when percentage evaluation is called. If a manual abort is not carried out, the device automatically returns to read mode after 5 min.

### Code configuration

In the factory default setting, the device decodes the following code types:

- Code 39
- 2/5 Interleaved
- Code 128 family

### Scanning frequency

The scanning frequency is 750 HZ, is cannot be adjusted.

### Object trigger control

If the device is to be operated with an additional read cycle sensor, for example, a photoelectric sensor on the “Sensor 1” switching input, select the “Sensor 1” setting (Device tree > Parameters > Reading configuration > Object trigger control).

Test and, if necessary, modify the specified settings when operating the system under real conditions.

### 8 Operation

#### 8.1 Operating options

The device can be configured according to application in the following manner:

- Locally at the device with the SOPAS ET configuration software. Protection of the parameter set as a configuration file on the PC in SOPAS ET. Access to the device via AUX interface.
- As an alternative to the SOPAS ET configuration software, command strings are available, upon which the operator interface of the configuration software is also based. These are also for the triggering of device functions (e.g. reading). Documents on the command strings can be obtained from SICK on request.

The SOPAS ET configuration software is used for device diagnostics in case of a fault.

In normal operation, the device operates fully automatically.

## 9 Maintenance

### 9.1 Maintenance

During operation, the device works maintenance-free.

Depending on the assignment location, the following preventive maintenance tasks may be required for the device at regular intervals:

Table 12: Maintenance schedule

Maintenance work	Interval	To be carried out by
Clean housing and front screen	Cleaning interval depends on ambient conditions and climate.	Specialist
Check screw connections and plug connectors	Interval depends on the place of use, ambient conditions, or operational regulations. Recommended: At least every 6 months.	Specialist
Check that the unused connections are sealed with protective caps or plugs	Interval depends on ambient conditions and climate. Recommended: At least every 6 months.	Specialist

### 9.2 Cleaning



#### NOTICE

##### Equipment damage due to improper cleaning.

Improper cleaning may result in equipment damage.

- Only use recommended cleaning agents.
- Never use sharp objects for cleaning.

#### Cleaning the reading window

At regular intervals, check the reading window and the housing of the device for accumulated dirt. This is especially relevant in harsh operating environments (dust, abrasion, damp, fingerprints, etc.).

The reading window lens must be kept clean and dry during operation.



#### NOTICE

##### Damage to the reading window.

Reduced analysis performance due to scratches or streaks on the window.

- Clean the window only when wet.
- Use a mild cleaning agent that does not contain powder additives. Do not use aggressive cleaning agents, such as acetone, etc.
- Avoid any movements that could cause scratches or abrasions on the window.
- Only use cleaning agents suitable for the screen material.



#### NOTE

Static charge causes dust particles to adhere to the reading window. This effect can be avoided by using an anti-static cleaning agent in combination with the SICK lens cloth (can be obtained from [www.sick.com](http://www.sick.com)).

#### Cleaning procedure:

- ▶ Clean the reading window only with a clean, damp, lint-free cloth, and a mild anti-static lens cleaning fluid.



### NOTICE

If the inspection window is scratched or damaged (cracked or broken), the lens must be replaced. Contact SICK Support to arrange this.

- If the inspection window is cracked or broken, take the device out of operation immediately for safety reasons and have it repaired by SICK.

---

### Cleaning the housing

In order to ensure that heat is adequately dissipated from the device, the housing surface must be kept clean.

- ▶ Clear the build up of dust on the housing with a soft brush.

### Cleaning other optical surfaces

Depending on how the reading station is equipped, additional local sensors may have other surfaces with an optical effect installed (e.g., photoelectric sensor for an external reading pulse). Contamination on these sensors can result in faulty switching behavior.

- ▶ To avoid faulty switching behavior, remove dirt from the optical surfaces of the external sensors.

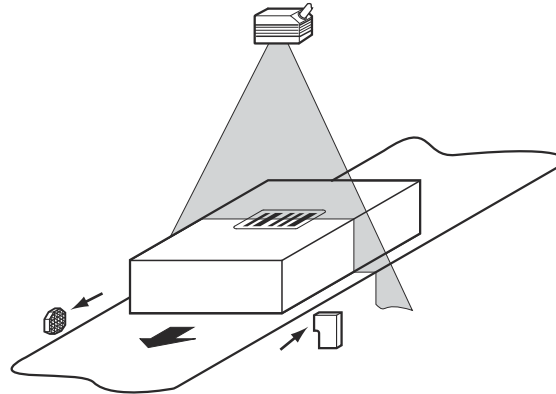

Figure 16: Cleaning the external optical sensors (read pulse encoder)



## 10 Troubleshooting

### 10.1 Overview of possible errors and faults



#### NOTICE

##### Danger due to damage to the device

For reasons of safety, if a device shows visible signs of damage do not put it into operation. Immediately take a device that is in operation out of operation.

Damage includes, depending on the type of device, for example the following:

- Viewing window pane: Cracked or broken
- Housing: Cracked or broken
- Violation of the cable outlet on the housing or the cable itself
- Overtightening of the male connector unit, tearing or breakage of the housing
- Moisture penetration in the device

Possible faults and corrective actions are described in the table below for troubleshooting.

Table 13: Errors and faults

Situation	Error or fault
Mounting	<ul style="list-style-type: none"> <li>■ Device poorly aligned to objects with bar codes(e.g., dazzle)</li> </ul>
Electrical installation	<ul style="list-style-type: none"> <li>■ Voltage supply not sufficiently dimensioned or cables with too small a cross-section used</li> </ul>
Configuration	<ul style="list-style-type: none"> <li>■ Functions not adapted to local conditions, e.g. parameters for the data interface not set correctly</li> <li>■ Device limits not observed, e.g. reading distance, aperture angle</li> <li>■ Trigger source for read cycle not selected correctly</li> </ul>
Operation	<ul style="list-style-type: none"> <li>■ Control of the reading pulse not correct or not suitable for the object</li> <li>■ Device faults (hardware/ software)</li> </ul>

### 10.2 Detailed fault analysis

#### 10.2.1 LEDs on the device

The conditions that can be read from the device LEDs on the sensor housing (see ["Status indicators", page 11](#)) include:

- Operational readiness (Ready)
- Reading result status (Good Read or No Read)
- Hardware fault
- Firmware download status
- Connection status of the device

The LED display can indicate possible errors or faults. Further information on this can be found in the "System Information" section.

#### 10.2.2 System information

The device outputs faults in different ways. Fault output is staggered and thus allows for an increasingly detailed level of analysis.

- Communication errors can occur when transmitting data to the device. The device then returns a fault code.
- For faults that occur during reading, the device writes fault codes in the status log (see "Status log", page 34).

### 10.3 Status log

---



#### NOTE

The status log is retained even after switching the device off and on again.

---

The device distinguishes between four types of fault:

- Information
- Warning
- Error
- Critical fault

The device saves only the last five entries for each fault type.

#### 10.3.1 Displaying the status log

To display the status log, the SOPAS ET configuration software must be connected with the device online.

1. Connect the SOPAS ET configuration software to the device.
2. Open CLV6xx in the project tree: Service > System Status > System Information tab.

### 10.4 Repairs

Repair work on the device may only be performed by qualified and authorized personnel from SICK AG. Interruptions or modifications to the device by the customer will invalidate any warranty claims against SICK AG.

### 10.5 Returns

- ▶ Do not dispatch devices to the SICK Service department without consultation.
- ▶ The device must be sent in the original packaging or an equivalent padded packaging.



#### NOTE

To enable efficient processing and allow us to determine the cause quickly, please include the following when making a return:

- Details of the contact person
  - Description of the application
  - Description of the fault that occurred
- 

### 10.6 Disposal

Any device which can no longer be used must be disposed of in an environmentally friendly manner in accordance with the applicable country-specific waste disposal regulations. Do not dispose of the product along with household waste.

**NOTICE****Danger to the environment due to improper disposal of the device.**

Disposing of devices improperly may cause damage to the environment.

Therefore, observe the following information:

- Always observe the valid regulations on environmental protection.
  - Separate the recyclable materials by type and place them in recycling containers.
-

## 11 Technical data



### NOTE

The relevant online data sheet for your product, including technical data, dimensional drawing, and connection diagrams can be downloaded, saved, and printed from the Internet:

- [www.sick.com/CLV60x](http://www.sick.com/CLV60x)

### 11.1 Features

	CLV601-xDxxx	CLV602-xDxxx	CLV601-xUxxx
<b>Connection type</b>	Cable		
<b>Reading window</b>	At front / At side	At front	At front / At side
<b>Scanner design</b>	Line scanner		
<b>Sensor</b>	CMOS line sensor		
<b>Sensor resolution</b>	2048 px		
<b>Light source</b>	LED (visible red light 626 nm)		
<b>LED class</b>	Risk group 0 (IEC 621471:2006-07 / EN 62471:2008-09)		
<b>Focus</b>	Fixed focus (30 mm)	Fixed focus (50 mm)	Fixed focus (30 mm)
<b>Aperture angle</b>	≤71°	≤62°	≤71°
<b>Interfaces</b>	RS-232		USB
<b>Scanning frequency</b>	750 Hz		
<b>Code resolution</b>	0.125 mm ... 0.5 mm	0.2 mm ... 0.5 mm	0.125 mm ... 0.5 mm
<b>Reading distance</b>	15 mm ... 70 mm; for details, <a href="#">see figure 17, page 37</a>	20 mm ... 105 mm; for details, <a href="#">see figure 18, page 37</a>	15 mm ... 70 mm; for details, <a href="#">see figure 17, page 37</a>
<b>Max. reading angle</b>	<b>Tilt <math>\alpha</math>:</b> <ul style="list-style-type: none"> <li>• ±5° (with code resolution ≥ 0.125 mm)</li> <li>• ±10° (with code resolution ≥ 0.15 mm)</li> <li>• ±15° (with code resolution ≥ 0.2 mm)</li> <li>• ±25° (with code resolution ≥ 0.35 mm)</li> </ul> <b>Pitch <math>\beta</math>:</b> <ul style="list-style-type: none"> <li>• ±6° (with code resolution ≥ 0.2 mm)</li> <li>• ±15° (with code resolution ≥ 0.5 mm)</li> </ul> <b>Skew <math>\gamma</math>:</b> <ul style="list-style-type: none"> <li>• ±20° (with code resolution ≥ 0.2 mm)</li> <li>• ±30° (with code resolution ≥ 0.5 mm)</li> </ul>	<b>Tilt <math>\alpha</math>:</b> <ul style="list-style-type: none"> <li>• ±5° (with code resolution ≥ 0.2 mm)</li> <li>• ±10° (with code resolution ≥ 0.25 mm)</li> <li>• ±15° (with code resolution ≥ 0.35 mm)</li> <li>• ±25° (with code resolution ≥ 0.50 mm)</li> </ul> <b>Pitch <math>\beta</math>:</b> <ul style="list-style-type: none"> <li>• ±6° (with code resolution ≥ 0.2 mm)</li> <li>• ±15° (with code resolution ≥ 0.5 mm)</li> </ul> <b>Skew <math>\gamma</math>:</b> <ul style="list-style-type: none"> <li>• ±20° (with code resolution ≥ 0.2 mm)</li> <li>• ±30° (with code resolution ≥ 0.5 mm)</li> </ul>	<b>Tilt <math>\alpha</math>:</b> <ul style="list-style-type: none"> <li>• ±5° (with code resolution ≥ 0.125 mm)</li> <li>• ±10° (with code resolution ≥ 0.15 mm)</li> <li>• ±15° (with code resolution ≥ 0.2 mm)</li> <li>• ±25° (with code resolution ≥ 0.35 mm)</li> </ul> <b>Pitch <math>\beta</math>:</b> <ul style="list-style-type: none"> <li>• ±6° (with code resolution ≥ 0.2 mm)</li> <li>• ±15° (with code resolution ≥ 0.5 mm)</li> </ul> <b>Skew <math>\gamma</math>:</b> <ul style="list-style-type: none"> <li>• ±20° (with code resolution ≥ 0.2 mm)</li> <li>• ±30° (with code resolution ≥ 0.5 mm)</li> </ul>
<b>MTTF</b>	67,0000 h		

### Reading field diagrams

Reading field height in mm (inch) ①

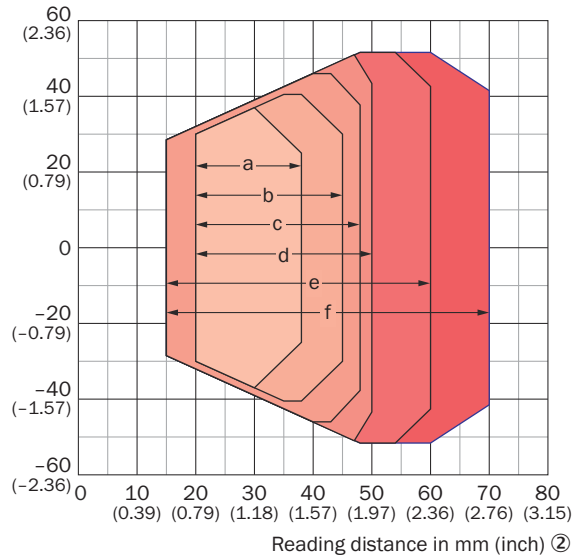

Figure 17: CLV601 reading field diagram

Reading field height in mm (inch) ①

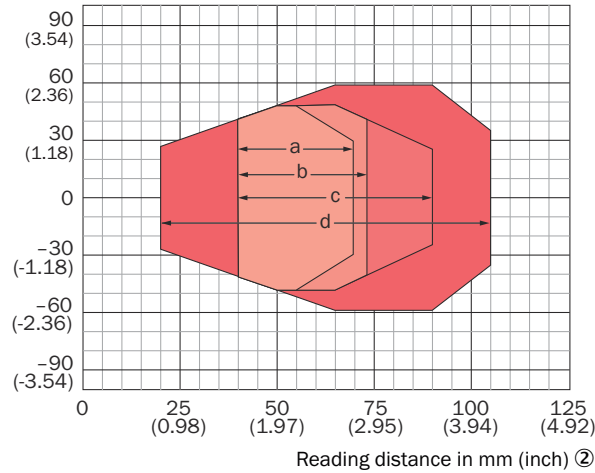

Figure 18: CLV602 reading field diagram

- ① Reading field height in mm (inch)
- ② Reading distance in mm (inch)
- ③ Resolution

#### CLV60x reading field diagram standard conditions:

- Code type 128 or 2/5 Interleaved
- Bar code print contrast (PCS) > 90%
- Tilt  $\alpha$  reading angle 0°

- Ambient light < 2,000 lx
- Rate of successful reads (Good Read) > 75%

## 11.2 Performance

	CLV601-xDxxx	CLV602-xDxxx	CLV601-xUxxx
Bar code types	All common code types, Code 39, Code 128, Code 93, Codabar, UPC / GTIN / EAN, 2/5 Interleaved		
Print ratio	2:1 ... 3:1		
No. of codes per scan	1 ... 1		
No. of codes per reading interval	1 ... 15 (auto-discriminating)		
No. of characters per reading interval	450		
Number of characters per code	≤ 30		
Number of multiple readings	1 ... 100		

## 11.3 Interfaces

Product type	CLV601-xDxxx	CLV602-xDxxx	CLV601-xUxxx
Type	RS-232 Function: Host, AUX Data transmission rate: 2400 Baud ... 250 kBaud, AUX: 57.6 kBaud		USB 2.0 Function: Keyboard connection, COM port emulation, connection to SOPAS ET software
Digital inputs (switching)	1 ("input 1", $V_{in} = \text{max. } 30 \text{ V}$ )		0
Digital outputs (switching)	2 ("output 1", "output 2" $i_{OUT} = \text{max. } 50 \text{ mA}$ )		Virtual (via SOPAS ET)
Reading pulse	Start: "Input 1" digital input, free, command, auto pulse Stop: "Input 1" digital input, free, command, timer, Good Read		Start: Free, command, auto pulse Stop: Command, timer, Good Read
Optical indicators	1 RGB-LED (multi-functional)		
Acoustic indicators	Beeper (can be switched off or allocated a function for indicating events)		
Configuration software	SOPAS ET		

## 11.4 Mechanics/electronics

Table 14: Technical data for mechanics/electronics

	CLV601-xDxxx	CLV602-xDxxx	CLV601-xUxxx
Electrical connection	1 x 9-pin D-Sub male connector		1 x USB-A male connector
Supply voltage	5 V DC, ±10 %		
Power consumption	1 W (typical)		
Housing	Zinc die cast		
Housing color	Light blue (RAL 5012), black (RAL 9005)		
Front screen	PMMA		

	CLV601-xDxxx	CLV602-xDxxx	CLV601-xUxxx
<b>Enclosure rating</b>	IP40 (EN 60529)		
<b>Protection class</b>	III (EN61140/IEC 1010-1)		
<b>Weight</b>	230 g, with connecting cable		170 g, with connecting cable
<b>Dimensions (L x W x H)</b>	55 mm x 52 mm x 20 mm		

### Dimensional drawings

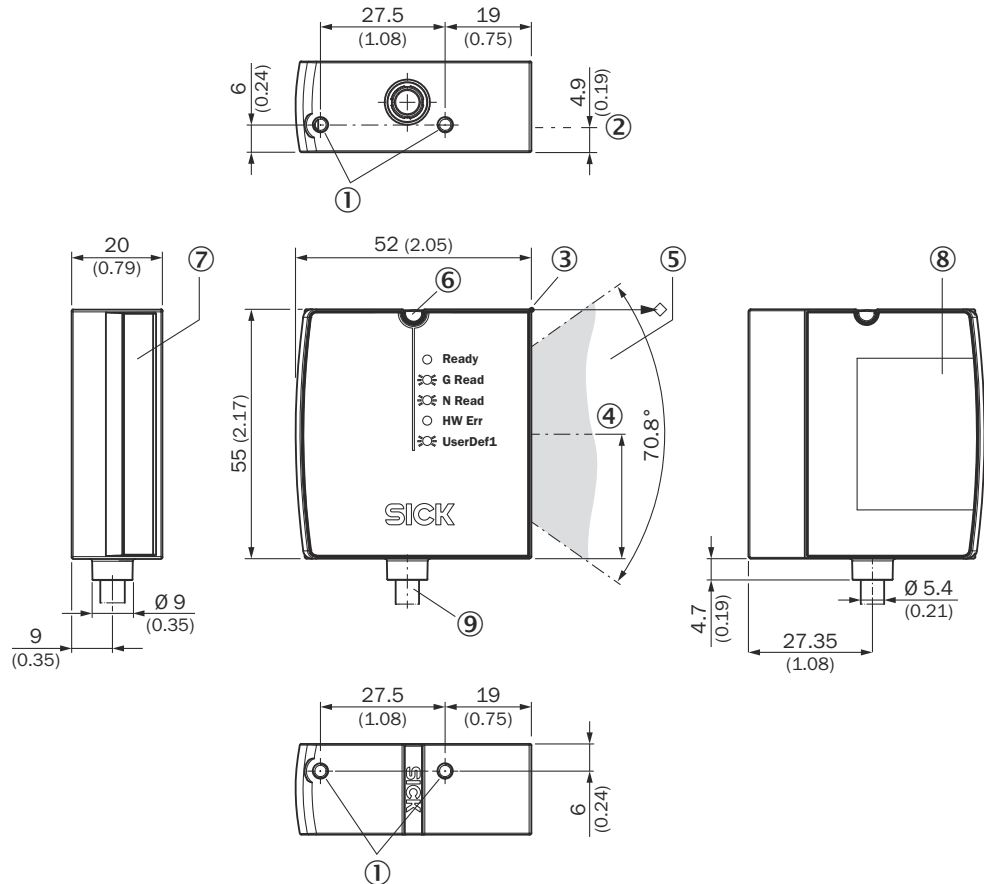

Figure 19: Dimensional drawing CLV60x-0xxxx, dimensions in mm

- ① Mounting thread M3 x 5 mm
- ② Optical axis, reading window
- ③ Reading distance reference point
- ④ Reading field axis center
- ⑤ Reading field
- ⑥ Status LED
- ⑦ Reading window
- ⑧ Type label
- ⑨ Connecting cable

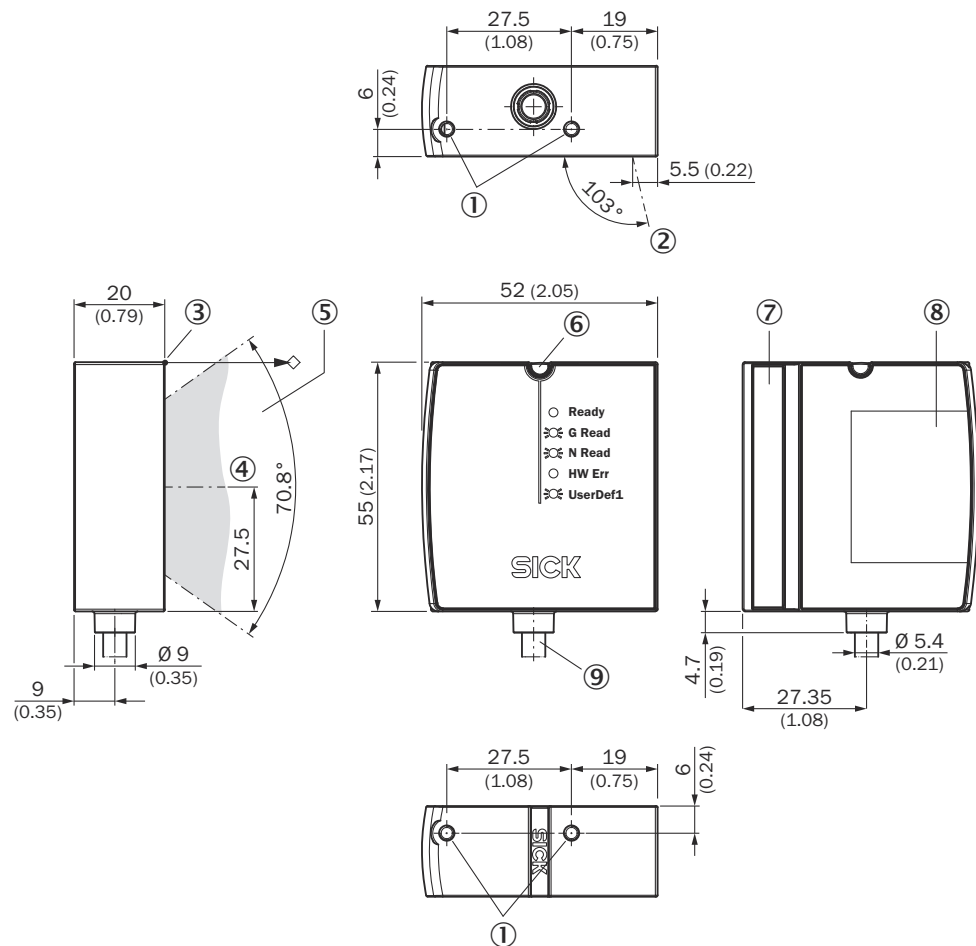

Figure 20: Dimensional drawing CLV60x-1xxxx, dimensions in mm

- ① Mounting thread M3 x 5 mm
- ② Optical axis, reading window
- ③ Reading distance reference point
- ④ Reading field axis center
- ⑤ Reading field
- ⑥ Status LED
- ⑦ Reading window
- ⑧ Type label
- ⑨ Connecting cable

### 11.5 Ambient data

	CLV601-xDxxx	CLV602-xDxxx	CLV601-xUxxx
<b>Electromagnetic compatibility (EM)</b>	EN 61000-6-2:2005: / IEC 61000-6-2:2005 (Industrial Environment) EN 61000-6-3:2007+A1:2011/IEC 61000-6-3:2006+AMD 1:2010		
<b>Vibration resistance</b>	EN 60068-2-6:2008-02		
<b>Shock resistance</b>	EN 60068-2-27:2009-05		
<b>Ambient operating temperature</b>	0 °C ... +50 °C		
<b>Storage temperature</b>	-20 °C ... +70 °C		



	CLV601-xDxxx	CLV602-xDxxx	CLV601-xUxxx
<b>Permissible relative humidity</b>	90%, non-condensing		
<b>Ambient light immunity</b>	5,000 lx, on bar code		
<b>Bar code print contrast (PCS)</b>	≥ 60%		

## 12 Annex

### 12.1 Declarations of conformity and certificates

The declarations of conformity and certificates can be downloaded from the Internet at:

- [www.sick.com/CLV60x](http://www.sick.com/CLV60x)

### 12.2 Certification according to UL62368



The devices in the CLV60x series are certified in accordance with UL 62368. The devices must be supplied by ES1 or Class 2 power supply units in order to ensure UL-compliant operation.

UL certification is only valid with corresponding device identification on the type label of the respective device; see [see "Type label", page 10](#).

The IP40 enclosure rating of the devices is not checked by UL.

### 12.3 Licenses

SICK uses open-source software. This software is licensed by the rights holders using the following licenses among others: the free licenses GNU General Public License (GPL Version2, GPL Version3) and GNU Lesser General Public License (LGPL), the MIT license, zLib license, and the licenses derived from the BSD license.

This program is provided for general use, but WITHOUT ANY WARRANTY OF ANY KIND. This warranty disclaimer also extends to the implicit assurance of marketability or suitability of the program for a particular purpose.

More details can be found in the GNU General Public License. View the complete license texts here: [www.sick.com/licensetexts](http://www.sick.com/licensetexts). Printed copies of the license texts are also available on request.



**Australia**  
Phone +61 (3) 9457 0600  
1800 33 48 02 – tollfree  
E-Mail sales@sick.com.au

**Austria**  
Phone +43 (0) 2236 62288-0  
E-Mail office@sick.at

**Belgium/Luxembourg**  
Phone +32 (0) 2 466 55 66  
E-Mail info@sick.be

**Brazil**  
Phone +55 11 3215-4900  
E-Mail comercial@sick.com.br

**Canada**  
Phone +1 905.771.1444  
E-Mail cs.canada@sick.com

**Czech Republic**  
Phone +420 234 719 500  
E-Mail sick@sick.cz

**Chile**  
Phone +56 (2) 2274 7430  
E-Mail chile@sick.com

**China**  
Phone +86 20 2882 3600  
E-Mail info.china@sick.net.cn

**Denmark**  
Phone +45 45 82 64 00  
E-Mail sick@sick.dk

**Finland**  
Phone +358-9-25 15 800  
E-Mail sick@sick.fi

**France**  
Phone +33 1 64 62 35 00  
E-Mail info@sick.fr

**Germany**  
Phone +49 (0) 2 11 53 010  
E-Mail info@sick.de

**Greece**  
Phone +30 210 6825100  
E-Mail office@sick.com.gr

**Hong Kong**  
Phone +852 2153 6300  
E-Mail ghk@sick.com.hk

**Hungary**  
Phone +36 1 371 2680  
E-Mail ertesites@sick.hu

**India**  
Phone +91-22-6119 8900  
E-Mail info@sick-india.com

**Israel**  
Phone +972 97110 11  
E-Mail info@sick-sensors.com

**Italy**  
Phone +39 02 27 43 41  
E-Mail info@sick.it

**Japan**  
Phone +81 3 5309 2112  
E-Mail support@sick.jp

**Malaysia**  
Phone +603-8080 7425  
E-Mail enquiry.my@sick.com

**Mexico**  
Phone +52 (472) 748 9451  
E-Mail mexico@sick.com

**Netherlands**  
Phone +31 (0) 30 229 25 44  
E-Mail info@sick.nl

**New Zealand**  
Phone +64 9 415 0459  
0800 222 278 – tollfree  
E-Mail sales@sick.co.nz

**Norway**  
Phone +47 67 81 50 00  
E-Mail sick@sick.no

**Poland**  
Phone +48 22 539 41 00  
E-Mail info@sick.pl

**Romania**  
Phone +40 356-17 11 20  
E-Mail office@sick.ro

**Russia**  
Phone +7 495 283 09 90  
E-Mail info@sick.ru

**Singapore**  
Phone +65 6744 3732  
E-Mail sales.gsg@sick.com

**Slovakia**  
Phone +421 482 901 201  
E-Mail mail@sick-sk.sk

**Slovenia**  
Phone +386 591 78849  
E-Mail office@sick.si

**South Africa**  
Phone +27 10 060 0550  
E-Mail info@sickautomation.co.za

**South Korea**  
Phone +82 2 786 6321/4  
E-Mail infokorea@sick.com

**Spain**  
Phone +34 93 480 31 00  
E-Mail info@sick.es

**Sweden**  
Phone +46 10 110 10 00  
E-Mail info@sick.se

**Switzerland**  
Phone +41 41 619 29 39  
E-Mail contact@sick.ch

**Taiwan**  
Phone +886-2-2375-6288  
E-Mail sales@sick.com.tw

**Thailand**  
Phone +66 2 645 0009  
E-Mail marcom.th@sick.com

**Turkey**  
Phone +90 (216) 528 50 00  
E-Mail info@sick.com.tr

**United Arab Emirates**  
Phone +971 (0) 4 88 65 878  
E-Mail contact@sick.ae

**United Kingdom**  
Phone +44 (0)17278 31121  
E-Mail info@sick.co.uk

**USA**  
Phone +1 800.325.7425  
E-Mail info@sick.com

**Vietnam**  
Phone +65 6744 3732  
E-Mail sales.gsg@sick.com

Detailed addresses and further locations at [www.sick.com](http://www.sick.com)