

Valve proving system MTC10

MTC10 is a device used to verify the tightness of the both automatic valves before every start-up of the burner or after every shut down.

Whenever a leakage is detected at one of the gas valves, MTC10 prevents the burner from starting up.

MTC10 is made in compliance to norm EN746-2 that states that installation of tightness control is mandatory in plants with power over 1200 kW.

This device may be used on industrial and domestic gas burners with or without venting pipe.

Certified **CE** according EN1643.

Conformity according to Directive 2009/142/CE (gas directive), Directive 2004/108/CE (EMC) and Directive 94/9/CE (Directive ATEX).



TECHNICAL FEATURES

Supply voltage	230Vac and 110V ac - 50 Hz
Rating at 230V	3,2 VA
Working exit	2 A
Fault exit	1 A
Fuse	6,3 A delayed
Environment temperature	-20 +60 °C
Enclosure	IP65
Test cycle	About 60 s
Installation position	Any position
Operation	Continuos

DEVICE SETTING

Valve proving system MTC10 can work according to three different settings : Standard (STD), EVA e EVP

TIPO DI SETTAGGIO	SETTAGGIO DEEP SWITCH	LED
STD	ON DIP 1 2 3 4	● ○ ○ ○
EVA	ON DIP 1 2 3 4	● ● ● ○
EVP	ON DIP 1 2 3 4	● ● ○ ○

DIMENSIONS

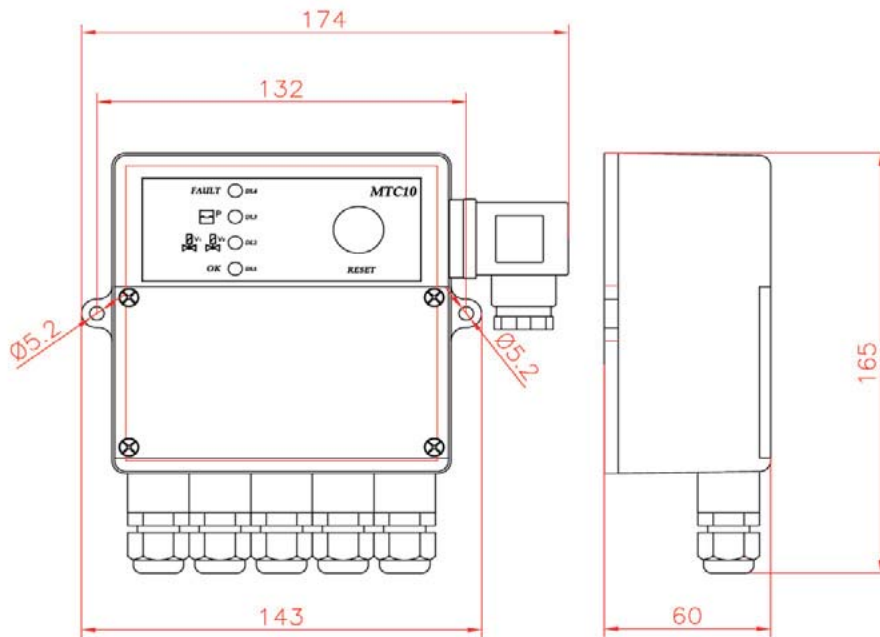

SETTINGS

STANDARD SETTING

The device makes the leakage test on the valves before the burner starts. Together with one or two pressure switches MTC10 checks the pressure in the testing section (volume between the seat of the valve V1 and the seat of the valve V2).

The test cycle can be easily followed on the display as per table n°1.

The test cycle lasts about 60 seconds and starts when the device is powered or when, after a lock-out, or when the reset button is pushed.

At the beginning the MTC10 performs an internal self test of leds, a configuration check, lock-out and relays check.

Once the self internal test is completed, the valve-test starts.

During all the test sequence the n°4 led stays on with red flashing light.

• Test V1

The V2 valve opens for 3 seconds max. This operation is called Ventilation.

The pressure inside the test section must decrease to the value of the pressure in the combustion chamber.

During the next 20 seconds (stabilization) the pressure inside the test section is monitored. If the pressure stays lower the pressure switch setting V1 valve is considered tight and the test carries on. If the pressure goes over the pressure switch setting point it means that there is a leak on the V1 valve and the fault relay is activated (clamp 14).

• Test V2

The valve V1 opens for 3 seconds max. This operation is called filling. The pressure inside the test chamber must increase up to the inlet pressure value. During the next 20 seconds (Stabilization) the test chamber pressure is monitored. If the pressure stays over the pressure switch setting V2 valve is considered tight and the test carries on.

If the pressure decrease till the pressure switch setting point this mean there is a leak on the V2 valve and the fault relay is activated (clamp 14).

Test OK

Once the valves leak tests are finished the Test OK relay is activated (clamp 15) and the device waits for the consent for the opening of the valves, phase identified by green flashing light of the led "OK".

In the presence of valves opening signal the led "OK" gets on with fix green light.

The signal to the valves will be supplied according the chosen configuration.

In case of failed ventilation or filling the device will try to repeat those operations again. After 5 failed attempts the device locks signalling a valve leakage.

STANDARD SETTING SCHEME

MTC10 controls valves V1 and V2.

Before the burner starts the following checks are to be made:

- 1° Test V1
- 2° Test V2

Once the test is passed the device open the valve related to the signal supplied (V1 - V2)

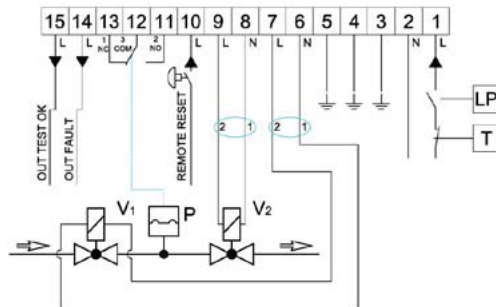
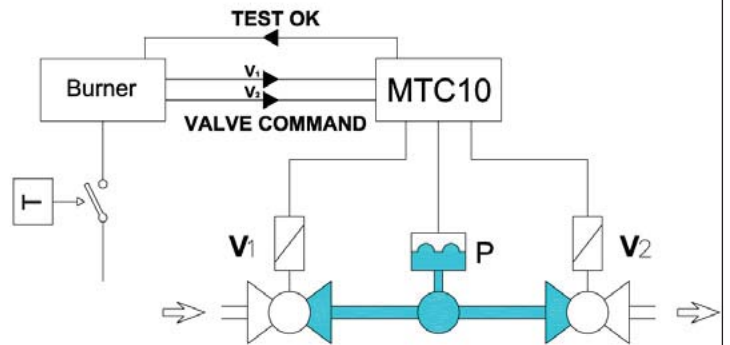

EVA SETTING

MTC10 controls valves V1 and V5.

The Burner Control controls V2 valve.

Before the burner starts the following checks are to be made:

- 1° Test V1
- 2° Test V2 and V5

During tightness test V5 releases to atmosphere to avoid, when forbidden, gas to be discharged to the combustion chamber.

Once the test is passed then the device open V1 (V5 stays closed) and the Burner Control opens V2 valve.

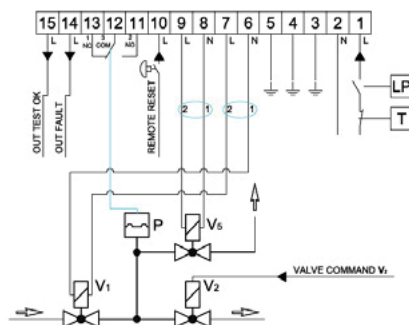
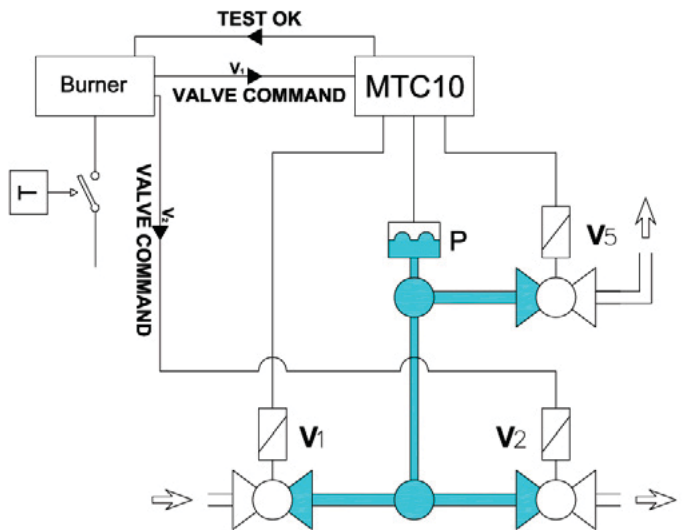

EVP SETTING

MTC10 controls valves V1 and V4.
The Burner Control controls V2 valve.

Before the burner starts the following checks are to be made:

- 1° Test V1
- 2° Test V2 and V4

During tightness test V4 releases to atmosphere to avoid, when forbidden, gas to be discharged to the combustion chamber.

Once the test is passed then the device opens V1 (V4 stays closed) and the Burner Control opens V2 valve.

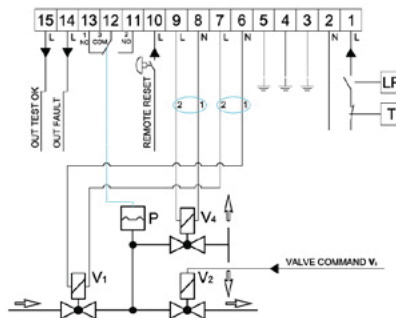
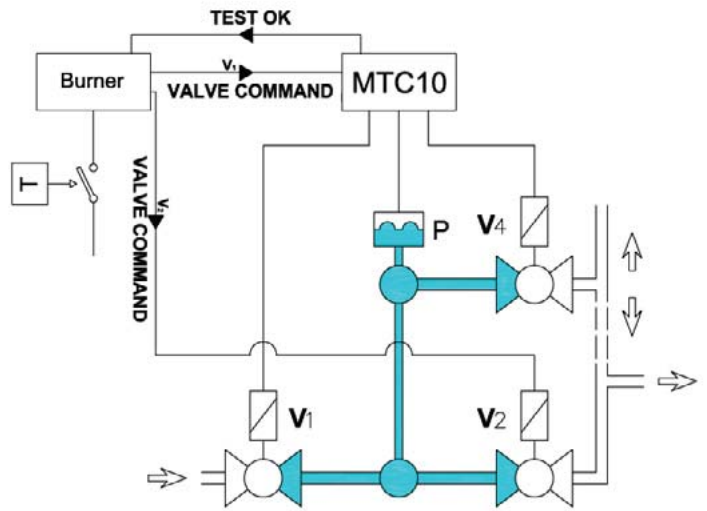

VALVE PROVING SYSTEM LOCK-OUT

If on the test sequency a leak in one of the two valves, a pressure switch fault or a mistake on the control board have been found, the device locks. The lock is memorized by the device and stays on even in case of electricity cut off.

To release the device it is necessary to keep pushed the "RESET" button (9) for at least 5". It is possible to release the lock using a remote control connecting throw the terminal board (10). Using the release throw the remote control, the device accept maximum 5 non stop releases in 15 minutes.

After those releases, the remote control release will not be available anymore. To release the device push the "RESET" button (9) placed on the device.

The release function stays always active without any operation and time limitation pushing the "RESET" button (9) placed on the device.

The leds present on the device supply the informations needed to identify and to solve the locks.