

FLANGED CAST IRON GAS BALL VALVE

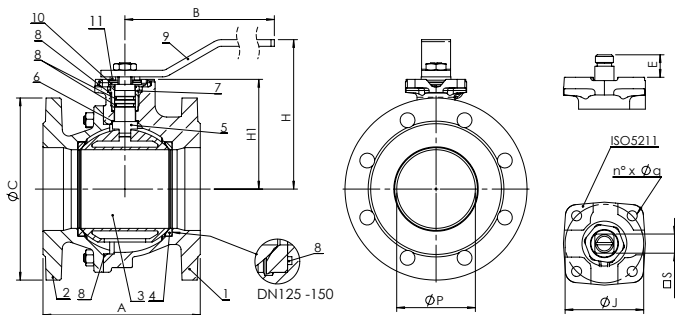

Code	Dimension	Pmax
BVD15D	DN15	PN16
BVD20D	DN20	PN16
BVD25D	DN25	PN16
BVD32D	DN32	PN16
BVD40D	DN40	PN16
BVD50D	DN50	PN16
BVD65D	DN65	PN16
BVD80D	DN80	PN16
BVD100D	DN100	PN16
BVD125D	DN125	PN16
BVD150D	DN150	PN16
BVD200D	DN200	PN10



POS.	DESCRIPTION	MATERIAL
1	Body	EN GJS 400-15 / EN GJL250*, epoxy coated
2	Flange	EN GJS 400-15 / EN GJL250*, epoxy coated
3	Ball	Brass CuZn40Pb2 chrome plated / AISI 304 / AISI 316 / EN GJL250**
4	Ball seat	Reinforced PTFE
5	Stem	Brass CuZn40Pb2 / AISI 304 / AISI 316
6	Sliding washer	PTFE
7	Ring	Brass CuZn40Pb2 / AISI 304 / AISI 316
8	O-Ring	NBR /FKM (Viton®)
9	Lever	Carbon steel, epoxy coated
10	Stop plate	Galvanized carbon steel
11	Spring washer	Galvanized carbon steel