

2

1

B

B

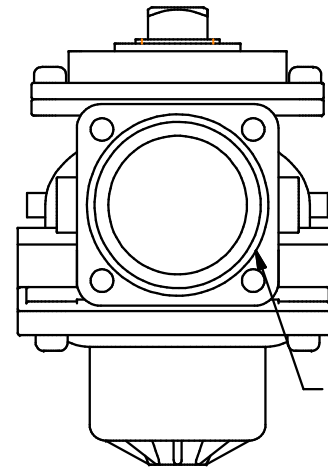
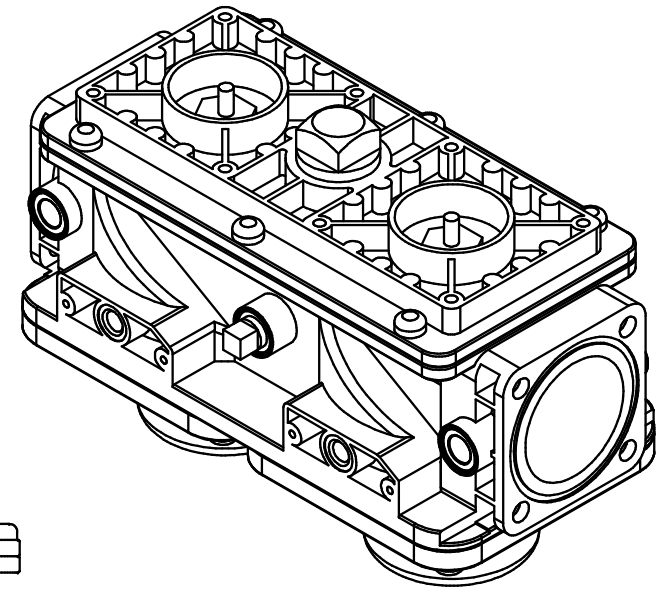
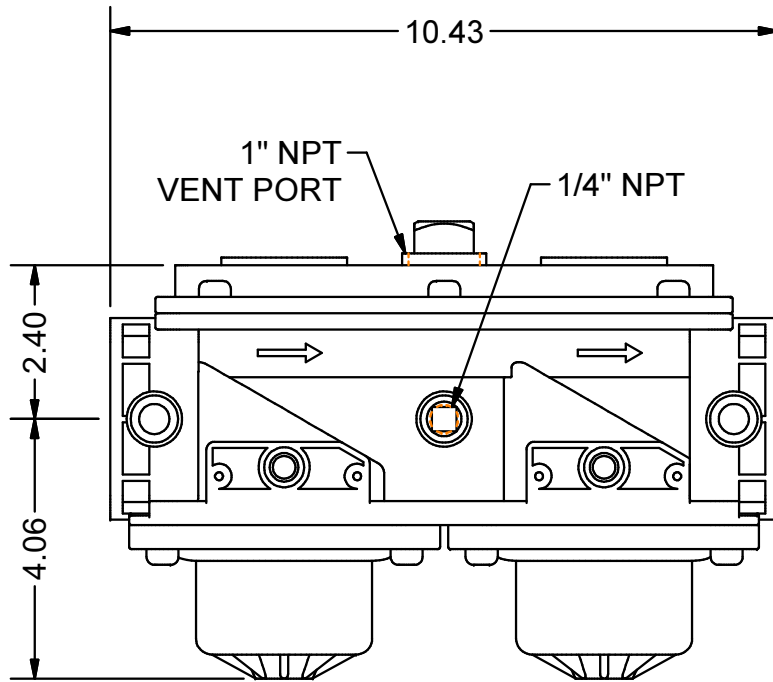

1-1/4" BODY
 (2) THREADED FLANGES (AGF10.xxU)
 ARE REQUIRED FOR INSTALLATION
 AND ARE AVAILABLE SEPARATELY

A

A

NOTE: DIMENSIONS FOR REFERENCE ONLY

REV.

1

MATERIAL		VALVE BODY: ALUMINUM			SCC Inc. Elk Grove Village, IL 60007 PH# 224-366-8445			DESCRIPTION		
FINISH								Double Gas Valve Body (1-1/4" NPT)		
TOLERANCES (UNLESS OTHERWISE SPECIFIED)					ENGINEER	DRAWN BY	CHECKED BY	DATE ORIGINATED	SHEET	SCALE
FRACT.	.XX	.XXX	ANG.	ALL DIMENSIONS IN INCHES UNLESS NOTED	DJP	DJP		6/13/2016	1 of 1	1/3
	+/- 0/00	+/- 0.01	+/- 0.005							
This Drawing and all information contained in this Drawing is the Property of SCC Inc.								PART / DRAWING #		
								VGD20.323U		

2

1