

2

1

B

B

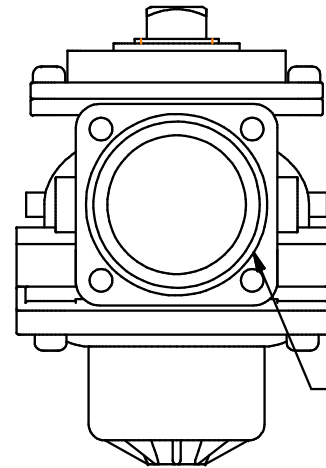
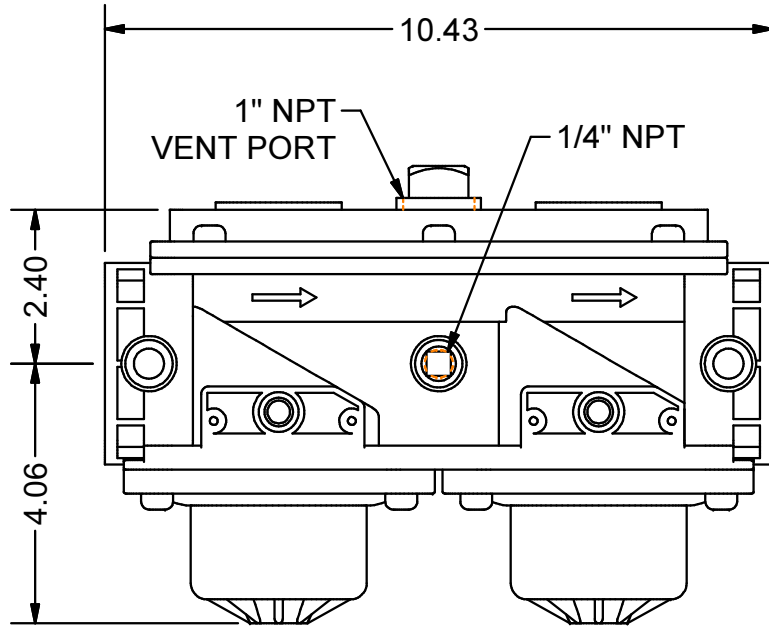

1" BODY
 (2) THREADED FLANGES (AGF10.xxU)
 ARE REQUIRED FOR INSTALLATION
 AND ARE AVAILABLE SEPARATELY

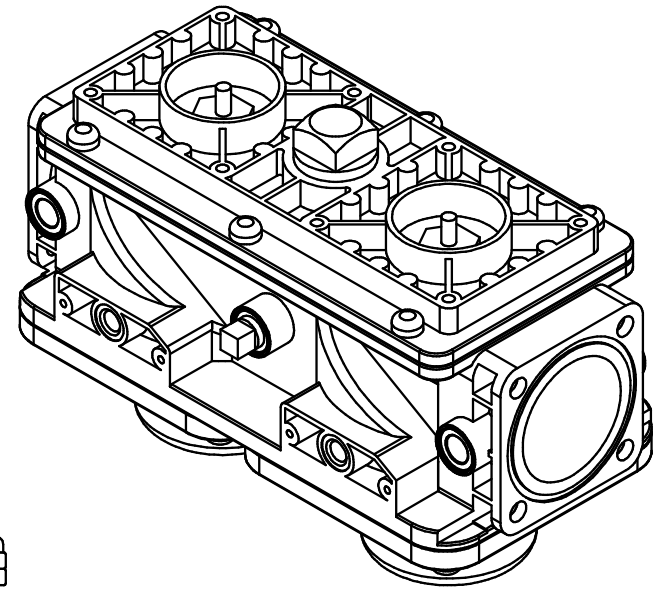

NOTE: DIMENSIONS FOR REFERENCE ONLY

REV.

1

MATERIAL		VALVE BODY: ALUMINUM			SCC Inc. Elk Grove Village, IL 60007 PH# 224-366-8445			DESCRIPTION			
FINISH								Double Gas Valve Body (1" NPT)			
TOLERANCES (UNLESS OTHERWISE SPECIFIED)					ENGINEER	DRAWN BY	CHECKED BY	DATE ORIGINATED	SHEET	SCALE	
FRACT.	.XX	.XXX	ANG.	ALL DIMENSIONS IN INCHES UNLESS NOTED	DJP	DJP		6/13/2016	1 of 1	1/3	
	+/- 0/00	+/- 0.01	+/- 0.005	+/- 0.5°	This Drawing and all information contained in this Drawing is the Property of SCC Inc.					PART / DRAWING #	
								VGD20.253U			

2

1

A

A