

2

1

B

B

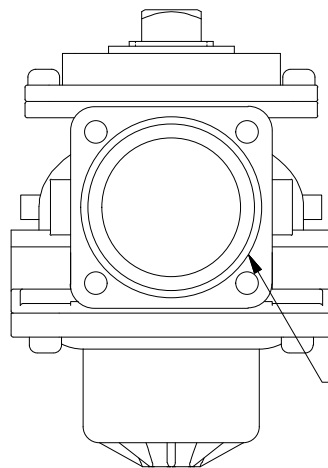
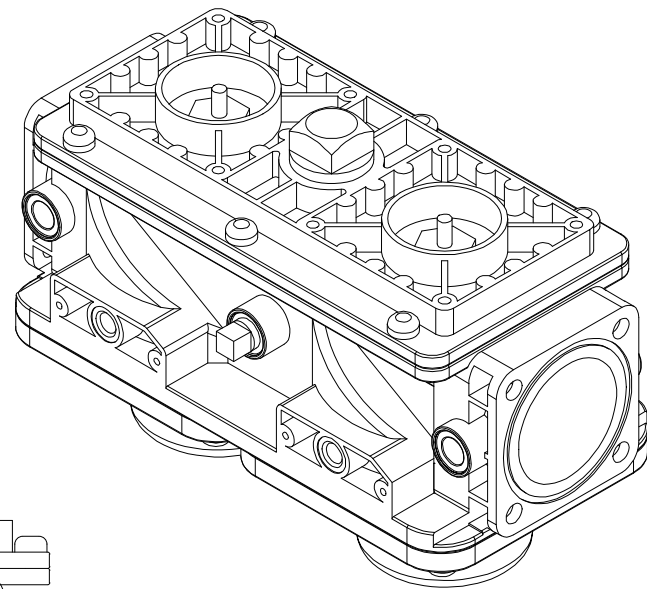
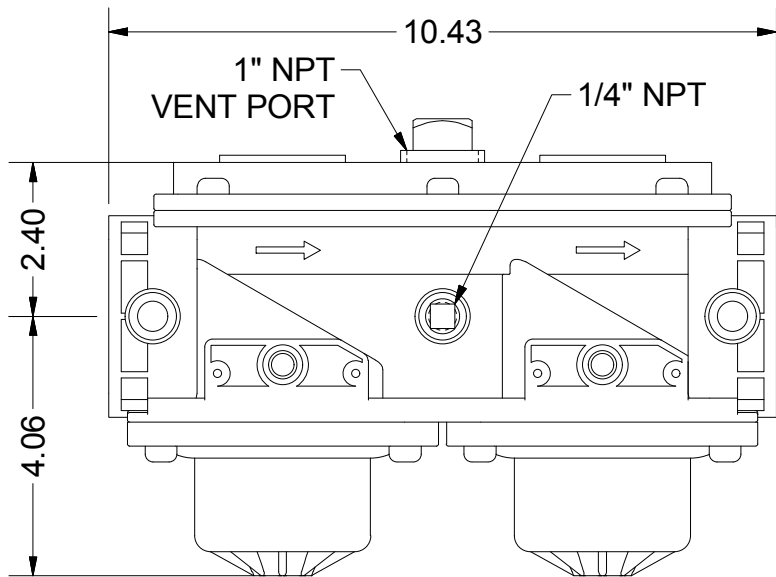

1-1/2" BODY  
 (2) THREADED FLANGES (**AGF10.xxU**)  
 ARE REQUIRED FOR INSTALLATION  
 AND ARE AVAILABLE SEPARATELY

A

A

REV.

1

NOTE: DIMENSIONS FOR REFERENCE ONLY

MATERIAL VALVE BODY: ALUMINUM					<b>SCC Inc.</b> Elk Grove Village, IL 60007 PH# 224-366-8445			DESCRIPTION		
FINISH								Double Gas Valve Body (1-1/2" NPT)		
TOLERANCES (UNLESS OTHERWISE SPECIFIED)					ENGINEER	DRAWN BY	CHECKED BY	DATE ORIGINATED	SHEET	SCALE
FRACT.	.XX	.XXX	ANG.	ALL DIMENSIONS IN INCHES UNLESS NOTED		DAG		1/7/2013	1 of 1	1/3
	+/- 0/00	+/- 0.01	+/- 0.005					PART / DRAWING #	VGD20.403U	
This Drawing and all information contained in this Drawing is the Property of SCC Inc.										

2

1