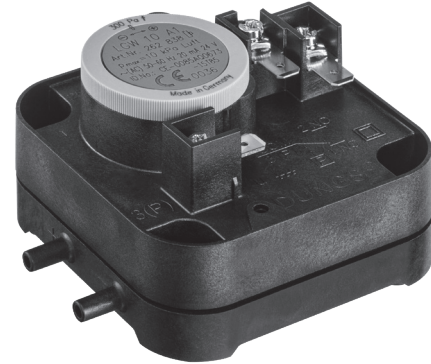





**Table of Contents**

Table of Contents ..... Page 1  
 Approvals ..... Page 1  
 Attention ..... Page 1  
 Specifications ..... Page 2  
 Model Designation Ranges ..... Page 2  
 Operation ..... Page 2  
 Pressure Connection ..... Page 2  
 Application & Connection Examples ..... Page 3  
 Installation Position ..... Page 3  
 Wiring ..... Page 3  
 Operation & Adjustment ..... Page 4  
 Maintenance & Testing ..... Page 4  
 Accessories & Replacement ..... Page 4



**Approvals**

-  **UL Recognized: UL 353**  
File # MH16628
-  **CSA Certified: CSA C22.2 No. 14**  
File # 201527
-  **FM Approved: Class 3510, 3530**  
File # J.I. 1T7A8.AF

Commonwealth of Massachusetts Approved Product Approval code G3-0106-191

**Attention**



The installation and maintenance of this product must be done under the supervision of an experienced and trained specialist. Never perform work if gas pressure or power is applied, or in the presence of an open flame.



Check the ratings in the specifications to verify that they are suitable for your application.



Please read the instruction before installing or operating. Keep the instruction in a safe place. You find the instruction also at [www.dungs.com](http://www.dungs.com). If these instructions are not heeded, the result may be personal injury or damage to property.



On completion of work on the pressure switch, perform a leakage and function test.



Any adjustment and application-specific adjustment values must be made in accordance with the equipment manufacturers instructions.



This product is intended for installations covered by, but not limited to, the following codes and standards: NFPA 86, ANSI Z83.4/CSA 3.7, ANSI Z83.18/CSA 4.9, ANSI Z21.13, CSD-1, UL 795, CSA B149.1 or CSA B149.3

**Explanation of symbols**

- 1, 2, 3 ... = Action
- = Instruction

## Specifications

**AA...A1** SPDT differential pressure switch in pressure and vacuum ranges. The differential pressure acts via the diaphragm against the force of the setting spring on the micro-switch. The pressure switch operates without any auxiliary power.



**Max. Operating Pressure**  
MOP = 1.5 PSI (103 mbar)

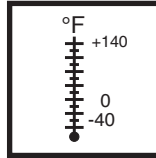

**Ambient / Medium Temperature**  
UL, FM  
-40 °F to +150 °F (-40 °C to +66 °C)  
CSA  
-40 °F to +104 °F (-40 °C to +40 °C)  
**Storage Temperature**  
-40 °F to +150 °F (-40 °C to +66 °C)



**Electrical Connection**  
1/4 x 1/32" (6.3 x 0.8 mm)  
flat male terminals

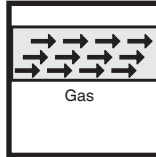

**Gases**  
Air and non-aggressive gases.  
**Not** suitable for natural gas, propane, butane and other combustible gases.

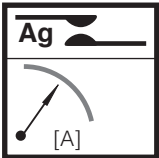

**Contact Rating**  
5 A resistive @ 240 VAC  
3 A inductive @ 240 VAC  
1 A @ 12 - 48 VDC

**Materials in contact with Gas**  
Housing: Polycarbonate  
Switch: Polycarbonate  
Diaphragm: NBR-based rubber  
Switching contact: Silver (Ag)

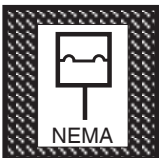

**Enclosure**  
IP 20 with appropriate cover

## Model Designation Ranges

Type	Version	Description	Order No.	Factory setting range in. W.C.	Switching hysteresis in. W.C.
AA-A1-0-...	AA-A1-0-2	No cover	277329	0.16 - 1.20	≤ 0.14
	AA-A1-0-3	No cover	277328	0.40 - 4.00	≤ 0.20

## Operation

### Definition of switching hysteresis $\Delta p$

The pressure difference between the upper and lower switching pressures.

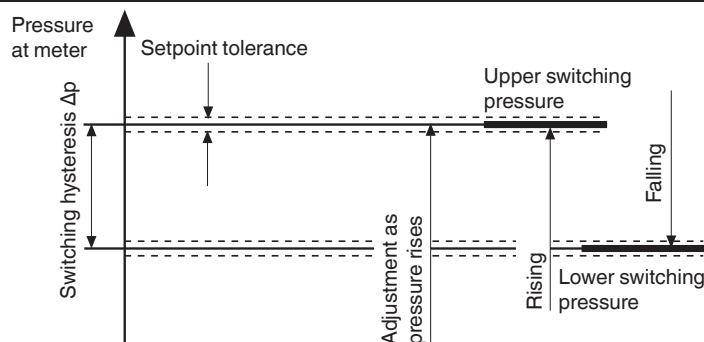

## Pressure Connection

Connection p1 (+) = higher pressure  
Connection p2 (-) = lower pressure

Optional  
Connection p3 (+) = higher pressure

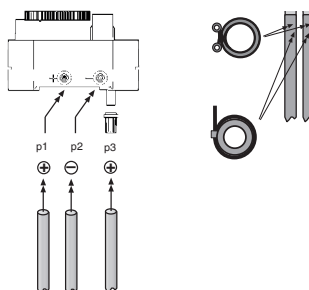

### AA...A1 Mounting Procedure

- Use suitable hoses for the medium.
- Use a maximum 5/32" ID hose
- Secure the hoses with a cable tie or a cable clip.

## Application & Connection Examples

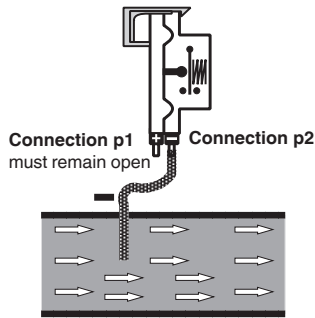

### System vacuum monitor

AA...A1 is connected to the air duct with the p2 (-) connection. p1 (+) is not connected with the air duct.

Do not seal the p1 (+) connection; it must be open to the atmosphere.

**⚠ Prevent dirt from entering into the device through connection p1(+)**

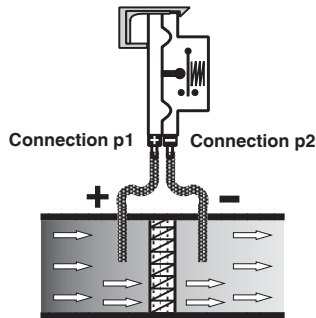

### Filter monitoring

To monitor a filter, the AA...A1 can be connected as shown above.

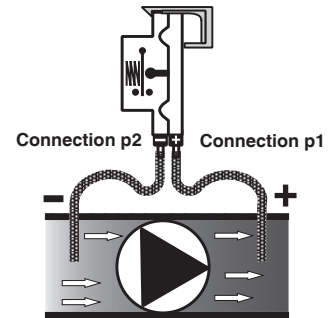

### Blower monitoring

For blower monitoring, connect connection p1 (+) to the air duct on the downstream side of the blower and connection p2 (-) to the air duct upstream of the blower.

## Installation Position

Standard installation position is **vertical** upright diaphragm.

When installed **horizontally**, the pressure switch switches at a pressure higher by approx. 0.2 in. W.C. When installed **upside down**, the pressure switch switches at a pressure lower by approx. 0.2 in. W.C. When installed in **other positions**, the pressure switch switches at pressure deviating from the set reference value by max.  $\pm 0.2$  in. W.C.

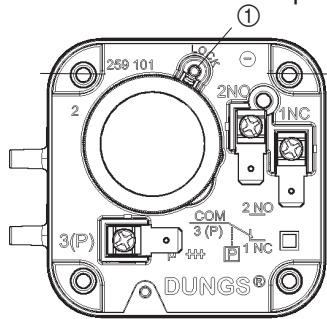

Refer to Label!

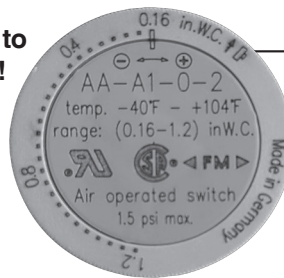

vertical  
Standard calibration

horizontally  
Scale value  
+0,2 in. W.C.

upside down  
Scale value  
-0,2 in. W.C.

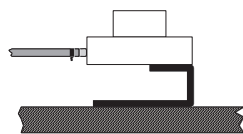

**⚠ Ensure that the pressure switch is installed free of vibration!**

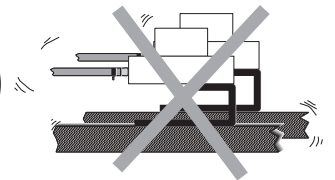

## Wiring

- If applicable, remove the clear cover from the switch.
- Use 14 or 16 AWG wire rated for at least 75 °C.
- Connect the wiring to the appropriate 1/4 x 1/32" (6.3 x 0.8 mm) flat male terminals.

**⚠ All wiring must comply with local electrical codes, ordinances and regulations.**

**⚠ Do not exceed the switch ratings given in the specifications and on the switch.**

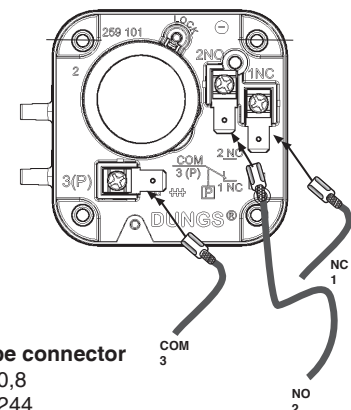
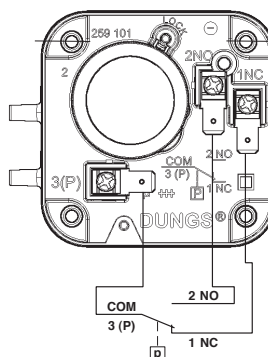

**Flat-type connector**  
A 6,3 x 0,8  
DIN 46 244

### AA-A1... switching function

**As pressure rises:**

1 NC opens, 2 NO closes

**As pressure falls:**

1 NC closes, 2 NO opens

## Operation & Adjustment

### Automatic Reset

- The NC contact of the AA...A1 breaks when pressure rises

above the set point. It makes automatically when pressure falls below set point.

## Maintenance & Testing

### Annually check the switch for proper operation

#### Set Point Calibration

1. Connect a meter capable of reading +/- 0.1 ohms to the NC and COM contacts.
2. Measure the resistance across the NC and COM contacts. If the resistance is more than 1.0 ohm, the switch should be replaced, since this indicates that the switch contacts are starting to either corrode or carbonizing.

3. Apply pressure to the + air pressure connection, and confirm that the NC contact breaks when pressure rises above the set point and that the NO contact makes. The NC contact will make automatically when pressure falls below the set point pressure.

4. Connect a meter capable of reading +/- 0.1 ohms to the NO and COM contacts.

5. Measure the resistance across the NO and COM contacts. If the resistance is more than 1.0 ohm, the switch should be replaced, since this indicates that the switch contacts are starting to either corrode or carbonizing.

## Accessories & Replacement

### Accessories for pressure switch      Order No.

IP 20 Cover (1 pcs)

262045



Mounting plate (1 pcs)

230301

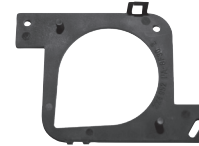

Screw ø 3 x 14 (2 pcs)

266045

Klima-Set (Duct mounting kit)

258247



Adapter ø 4/6 (2 pcs)

266037

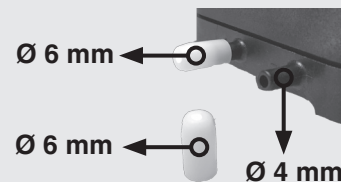

We reserve the right to make modifications in the course of technical development.

**Karl Dungs, Inc.**  
3890 Pheasant Ridge Drive NE  
Suite 150  
Blaine, MN 55449, U.S.A.  
Phone 763 582-1700  
Fax 763 582-1799  
e-mail [info@karldungsusa.com](mailto:info@karldungsusa.com)  
Internet <http://www.dungs.com/usa/>

**Karl Dungs GmbH & Co. KG**  
P.O. Box 12 29  
D-73602 Schorndorf, Germany  
Phone +49 (0)7181-804-0  
Fax +49 (0)7181-804-166  
e-mail [info@dungs.com](mailto:info@dungs.com)  
Internet <http://www.dungs.com>