



### Safety Shut-off Valve Type SAV

Direct acting shut-off device with adjustable setpoint springs for over-pressure and under-pressure monitoring

In compliance with EN 14382

- Inlet pressures up to 25 bar (2500 kPa)
- High flow rate
- Manual reset
- External impulse
- Maintenance-friendly
- Flange connection DN 25 - DN 50



Application	3
Approval	3
Technical data	4
Pressure taps	5
Nomenclature	6
Adjustment range	7
Selection of SAV springs	8
Dimensions	9
Function	10
Sectional drawing SAV	10
Device selection / flow diagram	11-13
Calculation of gas types	14
Contact details	15

## SAV

Spring-loaded, shut-off valve with adjustable setpoint springs for limitation of the upper and lower pressure downstream. External impulse of the valve downstream pressure.



## Application

Safety valve closes when over and under pressures occurs in industrial gas burners and gas heating appliances. Also for installation in the municipal and commercial gas supply.

Suitable for gases of gas families 1, 2, 3 and other neutral gases.

## Approval

EC type testing certificate as per:

- EC-Pressure Equipment Directive

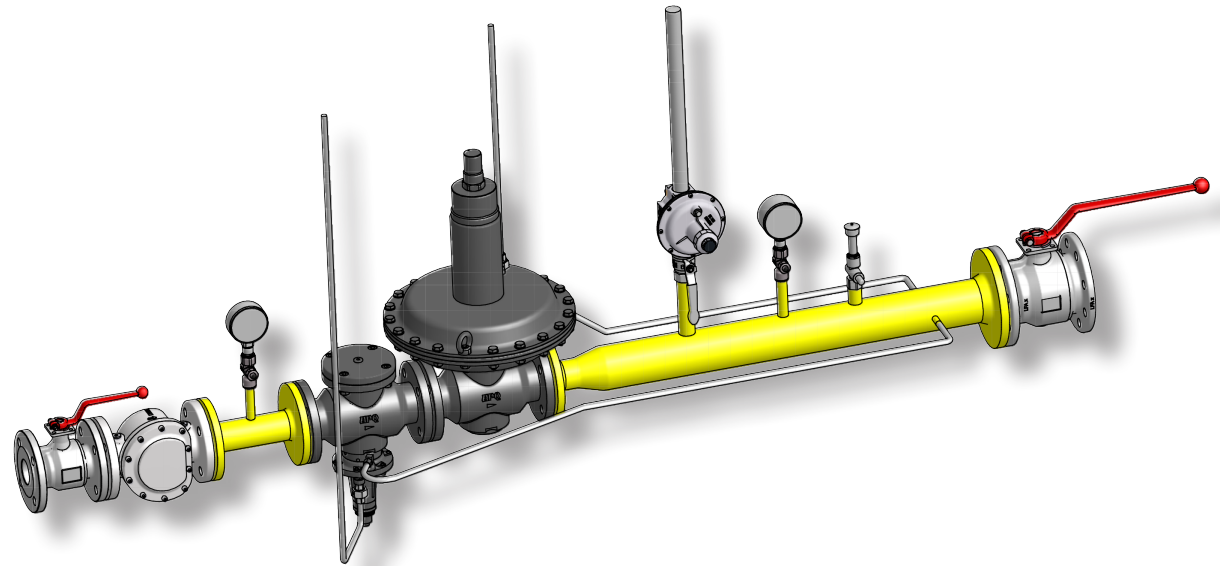



### Safety shut-off valve in compliance with EN14382, class A

Type	SAV 100... IS (integral strength range) / SAV 250... DS (differential strength range)	
Type of gas	Family 1+2+3	
Nominal diameters Flanges	Connecting flange PN 25 according to EN1092-1 or ANSI 150 lbs (B16.5) DN 25 40 50	
Max. inlet pressure	SAV 100... 10 bar (1000 kPa) / SAV 250... 25 bar (2500 kPa)*	
Response time	< 2 s	
Lower adjustment range $W_{du}$	10 mbar up to 3000 mbar (1-300 kPa)	
Upper adjustment range $W_{do}$	40 mbar up to 5000 mbar (4-500 kPa)	
Materials	Main body housing:	cast iron GGG 50 (GJS 400-18 on request)
	Diaphragm housing:	aluminium (steel on request)
	Diaphragms:	NBR
Ambient temperature	-20 °C to +60 °C	

\*19 bar (1900 kPa) with ANSI 150 flanges

Pressure taps

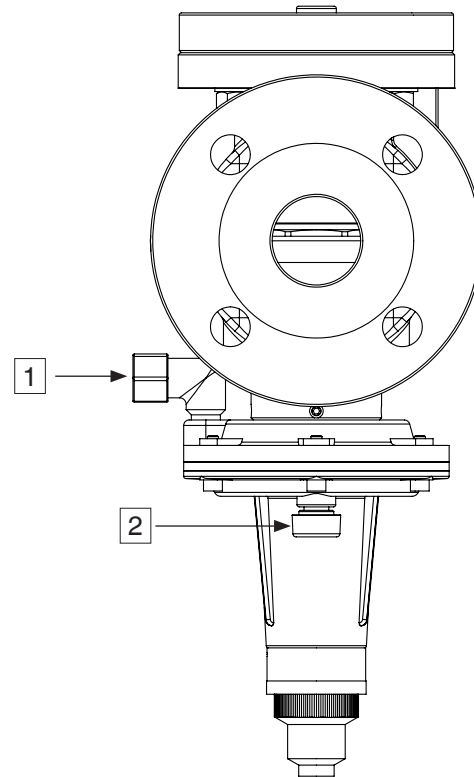

- 1 External impulse line connection of the SAV, Ermeto screw connection  
GE 12- ¼ for tubes 12 x 1.5
- 2 Vent line connection of the SAV,  
G ¼ ISO 228

**Nomenclature**



<b>Example SAV 100025 ND</b>	<b>SAV</b>	<b>100</b>	<b>025</b>	<b>ND</b>	<b>ANSI</b>
<b>Type</b>	Safety Shut-off valve				
<b>MOP</b>	100 ...	10 000 mbar			
	250 ...	25 000 mbar			
<b>Nominal diameter</b>	DN 25	025			
	DN 40	040			
	DN 50	050			
<b>Pressure range, trip pressure</b>	ND	Low pressure			
	MD	Medium pressure			
	HD	High pressure			
	UHD	Ultra high pressure			
<b>Flange type</b>	ANSI	with standard PN-25 with ANSI 150 lbs			

## Adjustment range



Type	Connection	Version	Order number	Lower switching point		Upper switching point	
				W <sub>du</sub>	AG	W <sub>do</sub>	AG
SAV 100025 ND	DN 25	ND	270290	10-15 mbar	AG 10	40-240 mbar	AG 10
SAV 100025 MD	DN 25	MD	270291	35-400 mbar	AG 10	180-800 mbar	AG 10
SAV 100025 HD	DN 25	HD	270292	150-1400 mbar	AG 5	500-3500 mbar	AG 5
SAV 250025 UHD	DN 25	UHD	271122	150-3000 mbar	AG 5	500-5000 mbar	AG 5
SAV 100040 ND	DN 40	ND	270293	10-115 mbar	AG 10	40-240 mbar	AG 10
SAV 100040 MD	DN 40	MD	270294	35-400 mbar	AG 10	180-800 mbar	AG 10
SAV 100040 HD	DN 40	HD	270295	150-1400 mbar	AG 5	500-3500 mbar	AG 5
SAV 250040 UHD	DN 40	UHD	271123	150-3000 mbar	AG 5	500-5000 mbar	AG 5
SAV 100050 ND	DN 50	ND	270296	10-115 mbar	AG 10	40-240 mbar	AG 10
SAV 100050 MD	DN 50	MD	270297	35-400 mbar	AG 10	180-800 mbar	AG 10
SAV 100050 HD	DN 50	HD	270298	150-1400 mbar	AG 5	500-3500 mbar	AG 5
SAV 250050 UHD	DN 50	UHD	271124	150-3000 mbar	AG 5	500-5000 mbar	AG 5

## Selection of SAV springs

The response pressure results from the force of the installed adjusting spring. The upper response pressure (overpressure) is set on the external **spring 1** of the measurement device. The lower response pressure (vacuum) can be set on the internal **spring 2**. By changing the setpoint springs, different response pressures can be set.

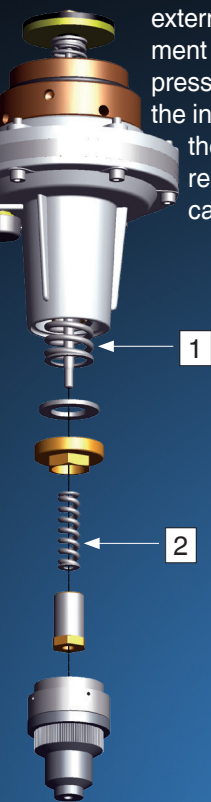

Specific set range, underpressure $W_{dsu}$								
Spring colour	Order number	Wire diameter [mm]	Length [mm]	Diameter [mm]	Setpoint range [mbar]			
					ND	MD	HD	UHD
White	270353	1.2	60	10.0	10-32			
Yellow	270355	1.5	55	12.3	24-40			
Blue	270356	2.0	55	12.3	30-115	35-110		
Black	270357	2.3	55	12.3		50-250		
Purple	270358	2.5	55	12.3		80-400	150-500	150-500
Orange	270359	2.8	55	12.3			300-1000	300-1000
Silver	270360	3.0	60	15.0			800-1400	800-1400
Pink	276126	3.5	60	15.0				1200-3000

Specific set range, overpressure $W_{dso}$								
Spring colour	Order number	Wire diameter [mm]	Length [mm]	Diameter [mm]	Setpoint range [mbar]			
					ND	MD	HD	UHD
Silver	270361	2.2	60	30.0	40-130			
Green	270366	2.5	60	30.0	60-190	180-290		
Red	270367	2.7	60	30.0	90-240	230-370		
Yellow	270368	3.2	60	30.0		300-500		
Blue	270369	3.5	60	30.0		400-800	500-1000	500-1000
Black	270370	3.7	60	30.0			700-1300	700-1300
Purple	270371	4.0	60	30.0			1000-1800	1000-1800
Orange	270372	4.5	60	30.0			1300-2500	1300-2500
Pink	270373	4.8	60	30.0			1800-3500	1800-3500
White	271115	5.0	60	30.0				2500-5000



## Dimensions SAV

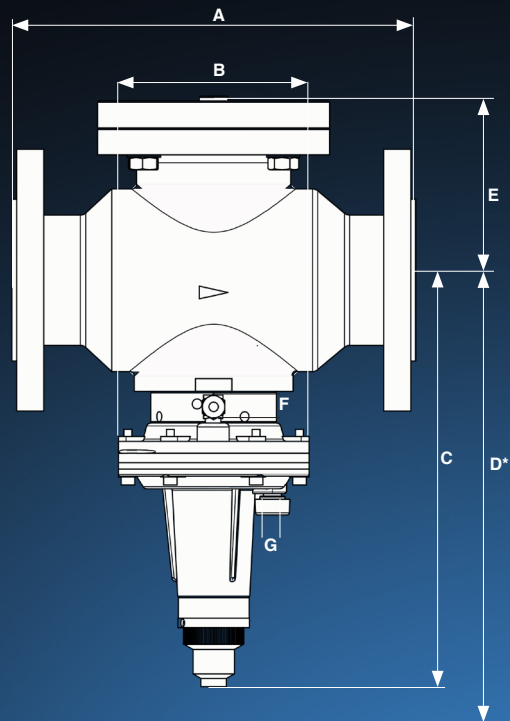

\* Space required for unlocking

Type	Order number	p max. [bar / kPa]	DN	Dimensions [mm]							Weight [kg]
				A	B	C	D	E	F	G	
SAV 100025 ND	270290	10 / 1000	25	184	120	232	482	83	12 x 1.5	Rp 1/4	7,6
SAV 100025 MD	270291	10 / 1000	25	184	120	229	479	83	12 x 1.5	Rp 1/4	7,6
SAV 100025 HD	270292	10 / 1000	25	184	120	236	486	83	12 x 1.5	Rp 1/4	7,6
SAV 250025 UHD	271122	25 / 2500	25	184	120	236	486	83	12 x 1.5	Rp 1/4	7,6
SAV 100040 ND	270293	10 / 1000	40	223	120	243	493	106	12 x 1.5	Rp 1/4	13,3
SAV 100040 MD	270294	10 / 1000	40	223	120	239	489	106	12 x 1.5	Rp 1/4	13,3
SAV 100040 HD	270295	10 / 1000	40	223	120	247	497	106	12 x 1.5	Rp 1/4	13,3
SAV 250040 UHD	271123	25 / 2500	40	223	120	247	497	106	12 x 1.5	Rp 1/4	13,3
SAV 100050 ND	270296	10 / 1000	50	254	120	252	502	116	12 x 1.5	Rp 1/4	16,0
SAV 100050 MD	270297	10 / 1000	50	254	120	248	498	116	12 x 1.5	Rp 1/4	16,0
SAV 100050 HD	270298	10 / 1000	50	254	120	256	506	116	12 x 1.5	Rp 1/4	16,0
SAV 250050 UHD	271124	25 / 2500	50	254	120	256	506	116	12 x 1.5	Rp 1/4	16,0

**Function**

**Information**

Gas carrying, impulse lines and connecting lines must be resistant to thermal, chemical and mechanical stresses. They must also be durable and resistant to deformation and cracks.

 Any condensate from impulse lines must not flow into closing device (ASE).

 Combustible gas and gas/air mixtures must not enter the installation space of the adjusting spring.

**Sectional drawing SAV  
Device in the closed position**

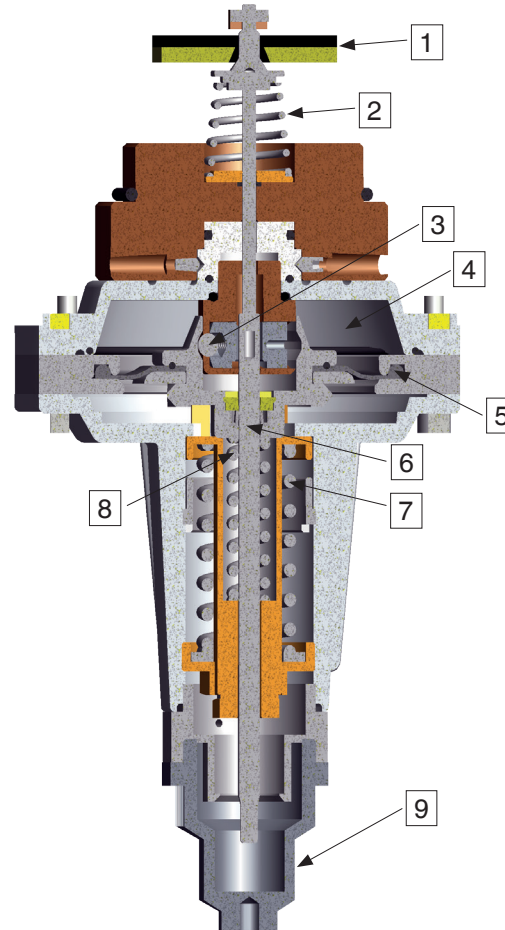





Chamber 4 is connected to the outlet pressure via an impulse line. The pressure being monitored acts on the working diaphragm 5. The force of the setpoint springs 7 and 8 acts as counterforce. In case of an unbalance of forces (overpressure or underpressure), the SAV is actuated and the gas supply is blocked.

- 1 Valve disc
- 2 Closing spring
- 3 Ball catch / trigger mechanism
- 4 Chamber with the pressure to be monitored
- 5 Working diaphragm
- 6 Push rod
- 7 Setpoint spring for  $pd_o$
- 8 Setpoint spring for  $pd_u$
- 9 Protective cap

## Device selection

The following flow rate tables can be used to select the device. With required flow at a certain inlet pressure, it can be defined the corresponding pressure drop. Flows are defined in natural gas ( $\rho=0,81\text{kg/m}^3$ ) or air ( $\rho=1,24\text{kg/m}^3$ ) at a temperature of  $15^\circ\text{C}$ . In case of different types of gases, a conversion of the volume flow according to the equation on page 14 is carried out.

-  Design a straight stabilisation section with the equal diameter.
-  Impulse connection at a distance of  $> 5 \times \text{DN}$ .
-  Maximum flow velocity = 50 m/s
-  Limit flow of 2.500 Nm<sup>3</sup>/h (Air)
-  Max. pressure difference  $\Delta p = 500 \text{ mbar}$

## Flow diagram

### SAV DN 25

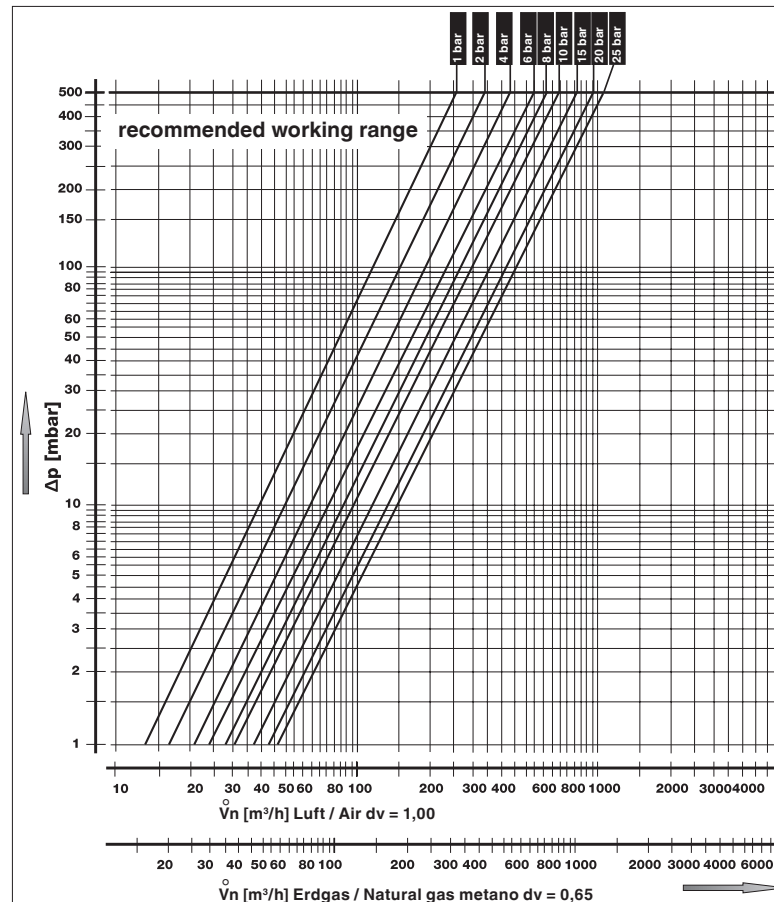

Based on  $+ 15^\circ\text{C}$ , 1013 mbar, dry

max. pressure difference  
 $\Delta p = 500 \text{ mbar}$   
max. flow velocity  
= 50 m/s

## Device selection

## Flow diagram

### SAV DN 40

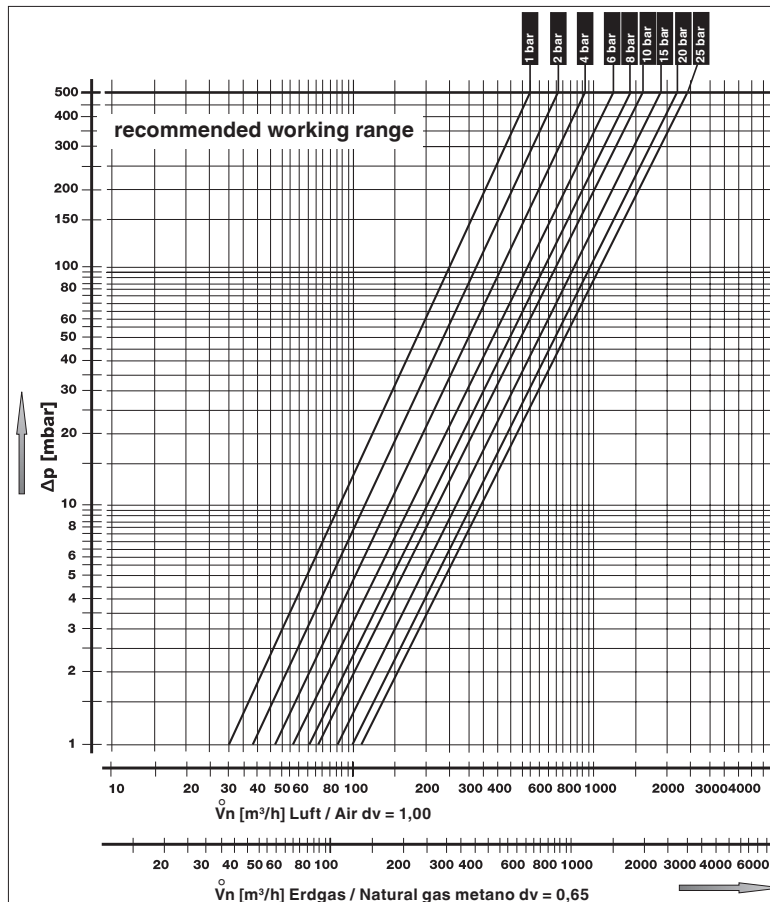

Based on + 15° C, 1013 mbar, dry

max. pressure difference  
 $\Delta p = 500$  mbar  
max. flow velocity  
= 50 m/s

## Device selection

## Flow diagram

### SAV DN 50

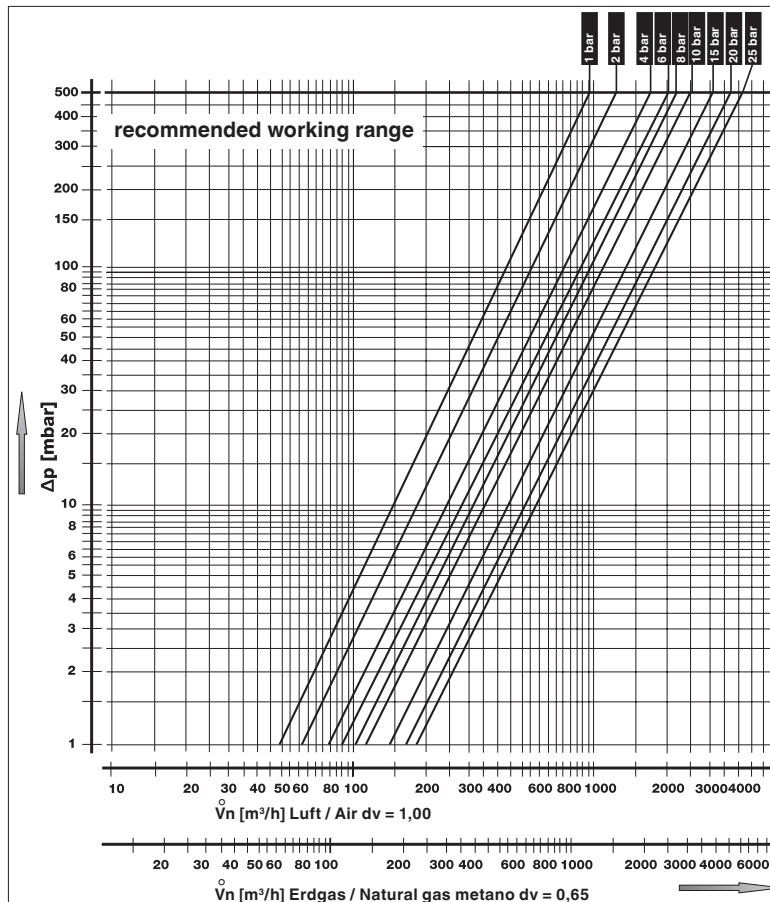

Based on + 15° C, 1013 mbar, dry

max. pressure difference  
 $\Delta p = 500$  mbar  
max. flow velocity  
= 50 m/s

Calculation of gas types



$\dot{V}_{\text{used gas}} = \dot{V}_{\text{air}} \times f$

$f = \sqrt{\frac{\text{air density}}{\text{spec. weight of the gas used}}}$

Type of gas	Spec. Wgt. [kg/m <sup>3</sup> ]	dv	f
Natural gas	0.81	0.65	1.24
City gas	0.58	0.47	1.46
NDG	2.08	1.67	0.77
Air	1.24	1.00	1.00



**Head of office and factory**

**Karl Dungs GmbH & Co. KG**  
Karl-Dungs-Platz 1  
D-73660 Urbach,  
Germany  
Phone +49 (0)7181-804-0  
Fax +49 (0)7181-804-166  
e-mail: [info@dungs.com](mailto:info@dungs.com)  
Internet: [www.dungs.com](http://www.dungs.com)

**Subsidiary**

**Karl Dungs, S.L.U.**  
Av. Can Roqueta Nº 15  
Pol. Ind. Can Roqueta  
E-08202 Sabadell  
Barcelona/Spain  
Phone +34 935 647-550  
e-mail: [info.e@dungs.com](mailto:info.e@dungs.com)  
Internet: [www.dungs.com](http://www.dungs.com)

Subject to technical modification in the interest of technical progress.