

# STÜBBE E-CLASS

## Centrifugal chemical plastic pump in monobloc design BE

Original operating manual

Pump series BE

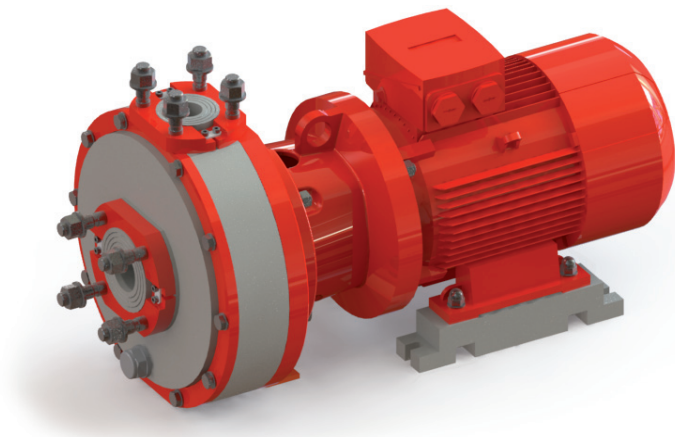

Version BA-2022.10.27 EN  
Print-No. 302 369  
TR MA DE Rev003

STÜBBE GmbH & Co. KG  
Hollwieser Straße 5  
32602 Vlotho  
Germany  
Phone: +49 (0) 5733-799-0  
Fax: +49 (0) 5733-799-5000  
E-mail: [contact@stuebbe.com](mailto:contact@stuebbe.com)  
Internet: [www.stuebbe.com](http://www.stuebbe.com)

Subject to technical modifications.

Read carefully before use.  
Save for future use.



## Table of contents

<b>1</b>	<b>About this document</b>	5	5.5.1	Making the electrical connections to the motor	19
1.1	Target groups	5	5.5.2	Check direction of rotation	19
1.2	Other applicable documents	5	5.6	Planning pipelines	20
1.3	Warnings and symbols	6	5.6.1	Specifying supports and flange connections	20
<b>2</b>	<b>General safety instructions</b>	7	5.6.2	Specifying nominal widths	20
2.1	Intended use	7	5.6.3	Specifying pipe lengths	20
2.2	General safety instructions	8	5.6.4	Provide self-priming container	20
2.2.1	Product safety	8	5.6.5	Optimizing changes of cross section and direction	20
2.2.2	Obligations of the operating company	8	5.6.6	Planning expansion joints	20
2.2.3	Obligations of personnel	8	5.6.7	Planning a non-return valve	21
2.3	Specific hazards	8	5.6.8	Planning venting facilities and pressure gauges	21
2.3.1	Hazardous pumped liquids	8	5.6.9	Discharging leaks	21
2.3.2	Potentially explosive atmospheres	9	5.6.10	Providing safety and control devices (recommended)	21
<b>3</b>	<b>Layout and Function</b>	10	5.7	Connecting the pipes	21
3.1	Marking	10	5.7.1	Keeping the piping clean	21
3.1.1	Name plate	10	5.7.2	Installing auxiliary pipes	21
3.1.2	ATEX type plate	10	5.7.3	Installing the suction pipework	22
3.1.3	Pump type code	11	5.7.4	Installing the pressure pipe	22
3.1.4	Mechanical seal type code	11	5.7.5	Inspection for stress-free pipe connections	22
3.2	Description	11	5.8	Performing the hydrostatic test	22
3.2.1	BE pump	11	<b>6</b>	<b>Operation</b>	23
3.2.2	BE ATEX pump	11	6.1	Preparing for commissioning	23
3.3	Assembly	12	6.1.1	Check downtimes	23
3.4	Mechanical seals - single-acting mechanical seal type STÜBBE UV4	13	6.1.2	Filling and bleeding	23
3.4.1	Version with internal flushing (product flushing) – API plan 01, type ES4N	13	6.1.3	Preparing auxiliary systems (if present)	23
3.4.2	Version with internal flushing and quenching – API plan 62, type QS4N	13	6.2	Commissioning	23
3.4.3	Version with standstill flushing (flushing after use) – API plan 32, type ES4S	14	6.2.1	Switching on	23
<b>4</b>	<b>Transport, Storage and Disposal</b>	15	6.2.2	Switching off	24
4.1	Transport	15	6.3	Shutting down the pump	24
4.1.1	Unpacking and inspection on delivery	15	6.4	Restoring the pump to service	24
4.1.2	Lifting	15	<b>7</b>	<b>Maintenance</b>	25
4.2	Storage	16	7.1	Inspections	25
4.3	Disposal	16	7.2	Servicing	25
<b>5</b>	<b>Installation and connection</b>	17	7.2.1	Maintenance in accordance with maintenance schedule	26
5.1	Preparing for installation	17	7.3	Dismounting	27
5.1.1	Check operating conditions	17	7.3.1	Preparations for dismounting	27
5.1.2	Preparing the installation site	17	7.4	Replacement parts and return	27
5.1.3	Prepare foundation and surface	17	<b>8</b>	<b>Troubleshooting</b>	28
5.2	Installing with foundation	17	<b>9</b>	<b>Appendix</b>	32
5.2.1	Place pump unit on the foundation	17	9.1	Replacement parts	32
5.2.2	Attaching pump unit	18	9.1.1	Part no. and description	32
5.3	Installing without foundation	18	9.1.2	Sectional drawing	34
5.4	Planning the electrical system	19	9.2	Technical specifications	35
5.5	Connecting the pump	19	9.2.1	Ambient conditions	35
			9.2.2	Sound pressure level	36

9.2.3	Flange tightening torques .....	38
9.2.4	Tightening torques of casing screws .....	38
9.2.5	Flushing quantity for quenching / continuous quenching .....	38
9.2.6	Operational limits .....	38
9.2.7	Switching frequency .....	39
9.3	Special tool .....	39
9.4	Declaration of conformity in accordance with EC machinery directive .....	40

## List of figures

Fig. 1	Name plate (example)	10
Fig. 2	ATEX type plate (example)	10
Fig. 3	Pump type code (example)	11
Fig. 4	Mechanical seal type code (example)	11
Fig. 5	Assembly (connection variant flange connection)	12
Fig. 6	Assembly (connection variant screw connection)	12
Fig. 7	Single-acting mechanical seal, version internal flushing	13
Fig. 8	single-acting mechanical seal, version internal flushing and quench	13
Fig. 9	Single-acting mechanical seal with standstill flushing	14
Fig. 10	Attaching lifting gear to the pump unit	15
Fig. 11	Installation with foundation	18
Fig. 12	Installation without foundation	18
Fig. 13	Connecting the motor	19
Fig. 14	Straight pipe lengths in front and after the pumps (recommended)	20
Fig. 15	Sectional drawing	34

## List of tables

Tab. 1	Other application documents, purpose and where found	5
Tab. 2	Warnings and symbols	6
Tab. 3	Measures to be taken if the pump is shut down	24
Tab. 4	Measures depending on the behavior of the pumped liquid	24
Tab. 5	Maintenance schedule	26
Tab. 6	Fault/number assignment	28
Tab. 7	Troubleshooting list	31
Tab. 8	Designation of components according to part numbers	33
Tab. 9	Ambient conditions	35
Tab. 10	Sound pressure (LpA) / sound power level (LwA) of the motor in db(A)	36
Tab. 11	Sound pressure (LpA) / sound power level (LwA) of the pump without motor in db(A)	36
Tab. 12	Flange tightening torques	38
Tab. 13	Tightening torques of casing screws	38
Tab. 14	Volumetric flow of the pumped medium	38
Tab. 15	Operating temperature and operating excess pressure of the pumped medium	39
Tab. 16	Switching frequency	39
Tab. 17	Special tool	39

## 1 About this document

This manual:

- is part of the equipment
- applies to all series referred to
- describes safe and proper operation during all operating phases

### 1.1 Target groups



#### Operating company

- Responsibilities:
  - Always keep this manual accessible where the device is used on the system.
  - Ensure that employees read and observe this document, particularly the safety instructions and warnings, and the documents which also apply.
  - Observe any additional country-specific rules and regulations that relate to the system.

#### Qualified personnel, fitter







- Mechanics qualification:
  - Qualified employees with additional training for fitting the respective pipework
- Electrical qualification:
  - Qualified electrician
- Transport qualification:
  - Qualified transport specialist
- Responsibility:
  - Read, observe and follow this manual and the other applicable documents, especially all safety instructions and warnings.

## 1.2 Other applicable documents

To download: <b>ATEX additional manual (300 365)</b> Additional instructions for use in explosive atmospheres  <a href="http://www.stuebbe.com/pdf_manuals/300365.pdf">www.stuebbe.com/pdf_manuals/300365.pdf</a>	
To download: <b>Resistance lists</b> Resistance of materials used to chemicals  <a href="http://www.stuebbe.com/pdf_resistance/300051.pdf">www.stuebbe.com/pdf_resistance/300051.pdf</a>	
To download: <b>Data sheet</b> Technical data and conditions of operation  <a href="http://www.stuebbe.com/pdf_datasheets/302363.pdf">www.stuebbe.com/pdf_datasheets/302363.pdf</a>	
<b>CE declaration of conformity</b> Conformity with standards  (→ 9.4 Declaration of conformity in accordance with EC machinery directive, Page 40).	

Tab. 1 Other application documents, purpose and where found

## 1.3 Warnings and symbols

Symbol	Meaning
	<ul style="list-style-type: none"> <li>• Immediate acute risk</li> <li>• Death, serious bodily harm</li> </ul>
	<ul style="list-style-type: none"> <li>• Potentially acute risk</li> <li>• Death, serious bodily harm</li> </ul>
	<ul style="list-style-type: none"> <li>• Potentially hazardous situation</li> <li>• Minor injury</li> </ul>
	<ul style="list-style-type: none"> <li>• Potentially hazardous situation</li> <li>• Material damage</li> </ul>
	<p>Safety warning sign</p> <ul style="list-style-type: none"> <li>▶ Take note of all information highlighted by the safety warning sign and follow the instructions to avoid injury or death.</li> </ul>
	Instruction
1., 2., ...	Multiple-step instructions
✓	Precondition
→	Cross reference
	Information, notes

Tab. 2 Warnings and symbols

## 2 General safety instructions

 The manufacturer accepts no liability for damages caused by disregarding any of the documentation.

### 2.1 Intended use

- Only use the pump with suitable media (→ resistance lists).
- Do not use the pump for flammable or explosive media.
- Adhere to the operating limits and size-dependent minimum flow rates (→ [Tab. 14 Volumetric flow of the pumped medium, Page 38](#)).
- This pump series is designed for indoor or protected installation only.
- Observe direction of rotation.
- Avoid running dry:  
Initial damage, such as destruction of bearings, seals and plastic parts, will occur within a few seconds.
  - Ensure that the pump is only started up with the pumped liquid and is not operated without the pumped liquid.
  - Ensure that the sealing chamber is sufficiently filled and ventilated.
  - Ensure that there are no excessively high amounts of gas in the pumping medium.
  - Only operate pump within the permissible operating range.
  - Ensure that the insertion of valves or filters does not make the pressure too low on the inlet side of the pump.
  - Ensure that high temperatures and/or low suction pressure at the suction side do not cause the pressure in the pump to fall below the vapor pressure of the pumped medium, and do not cause gas bubbles form around the mechanical seal.
  - Ensure that no air is being drawn in via the mechanical seal due to low supply pressure (negative pressure).
- Avoid cavitation:
  - Open the suction side fitting completely and do not use it to regulate the flow.
  - Do not open the pressure-side fitting beyond the agreed operating point.
- Avoid overheating:
  - Do not operate the pump against the closed pressure-side fitting.
  - Observe the minimum flow rate (→ [Tab. 14 Volumetric flow of the pumped medium, Page 38](#)).
- Avoid damage to the motor:
  - Do not open the pressure-side fitting beyond the agreed operating point.
  - Note the maximum permissible number of times the motor can be switched on per hour (→ [9.2.7 Switching frequency, Page 39](#)).
  - Do not exceed the maximum permissible speed.
- Consult with the manufacturer regarding any other use of the device.

- If pumps are delivered without motors, then final assembly as a pump assembly must take place in accordance with the provisions of the Machinery Directive 2006/42/EC.
- Use the pump only as part of a large system/tool.

#### Operate the pump in an explosion hazard environment (ATEX)

- Do not use pump for combustible or explosive fluids.
- Do not operate the pump with the isolation devices (such as gate valves and stop valves) closed.
- Operate the pump at the permissible minimum volumetric flow rate (→ [Tab. 14 Volumetric flow of the pumped medium, Page 38](#)).
- Ensure the necessary pressure and volumetric flow rate at the auxiliary ports (quench liquid / blocking liquid).
- Comply with the maintenance intervals.

#### Prevention of obvious misuse (examples)

- Observe pump limits of use regarding temperature, pressure, flow and speed (→ data sheet).
- The power consumption of the pump increases as the specific gravity of the pumped fluid increases. Adhere to the permissible specific gravity in order to eliminate the possibility that the pump and motor become overloaded (→ data sheet).  
A lower specific gravity is permissible. Adapt the auxiliary systems accordingly.
- When conveying fluids containing solids, observe the limit values for proportions of solid particles and particle size (→ Data sheet, technical description).
- When using auxiliary plant systems:
  - Ensure compatibility of the operating medium with the product medium.
  - Ensure constant supply of the relevant operating medium.
- Pumps used with water as the pumped liquid must not be used for foodstuffs or drinking water. Use for food or drinking water only if specified in the data sheet.
- When drawing flushing water from the normal drinking water main:
  - Use system separator for drink water main
- The type of installation should be selected only in accordance with these operating instructions. For example, the following are not allowed:
  - Suspension within pipework runs of pumps mounted on base plates
  - Overhead installation
  - Installation in the immediate vicinity of extreme heat or cold sources
  - Installation too close to a wall

## 2.2 General safety instructions

 Observe the following regulations before carrying out any work.

### 2.2.1 Product safety

The pump has been built according to state-of-the-art technology and the recognized technical safety regulations. Nevertheless, operation of the pump can still put the life and health of the user or third parties at risk or damage the pump or other property.

- Operate the pump only if it is in perfect technical condition and use it only as intended, staying aware of safety and risks, and in adherence to the instructions in this manual.
- Keep this manual and all other applicable documents complete, legible and accessible to personnel at all times.
- Refrain from any procedures and actions that would pose a risk to personnel or third parties.
- In the event of any safety-relevant faults, shut down the pump immediately and have the fault corrected by appropriate personnel.
- In addition to the entire documentation for the product, comply with statutory or other safety and accident-prevention regulations and the applicable standards and guidelines in the country where the pump is operated.

### 2.2.2 Obligations of the operating company

#### Safety-conscious working

- Operate the pump only if it is in perfect technical condition and use it only as intended, staying aware of safety and risks, and in adherence to the instructions in this manual.
- Ensure that the following safety aspects are observed and monitored:
  - Intended use
  - Statutory or other safety and accident-prevention regulations
  - Safety regulations governing the handling of hazardous substances
  - Applicable standards and guidelines in the country where the pump is operated
  - Applicable guidelines of the operator
- Make personal protective equipment available.

#### Qualified personnel

- Make sure all personnel tasked with work on the pump have read and understood this manual and all other applicable documents, especially the safety, maintenance and repair information, before they start any work.
- Organize responsibilities, areas of competence and the supervision of personnel.
- Ensure that all work is carried out by specialist technicians only:
  - Installation, repair and maintenance work
  - Transportation
  - Work on the electrical system

- Make sure that trainee personnel only work on the pump under supervision of specialist technicians.

#### Safety equipment

- Provide the following safety equipment and verify its functionality:
  - For hot, cold and moving parts: pump safety guarding provided by the customer
  - For pumps without capability to run dry: Dry run protection
  - For potential electrostatic charging: provide suitable grounding

#### Warranty

- Obtain the manufacturer's approval prior to carrying out any modifications, repairs or alterations during the warranty period.
- Only use genuine parts or parts that have been approved by the manufacturer.

### 2.2.3 Obligations of personnel

- All directions given on the pump must be followed (and kept legible), e.g. the arrow indicating the sense of rotation and the markings for fluid connections.
- Pump and components:
  - Do not step on them or use as a climbing aid
  - Do not use them to support boards, ramps or beams
  - Do not use them as a fixing point for winches or supports
  - Do not use them for storing paper or similar materials
  - Do not use the hot pump or motor components as a heating point
  - Do not de-ice the pump using gas burners or similar tools
- Do not remove the safety guarding for hot, cold or moving parts during operation.
- Use personal protective equipment if necessary.
- Only carry out work on the pump while it is not running.
- Before all installation and maintenance work, disconnect the motor from the mains and secure it against being switched back on again.
- Never reach into the suction or discharge flange.
- Following all work on the pump, refit safety devices in accordance with the instructions and bring into service.

## 2.3 Specific hazards

### 2.3.1 Hazardous pumped liquids

- When handling hazardous fluids, observe the safety regulations for the handling of hazardous substances.
- Use personal protective equipment when carrying out any work on the pump.
- Collect leaking pumped liquid and residues in a safe manner and damage them in accordance with environmental regulations.



## 2.3.2 Potentially explosive atmospheres

Observe ATEX additional manual

- Additional instructions for use in explosive atmospheres
- [www.stuebbe.com/pdf\\_manuals/300365.pdf](http://www.stuebbe.com/pdf_manuals/300365.pdf)



## 3 Layout and Function

### 3.1 Marking

#### 3.1.1 Name plate

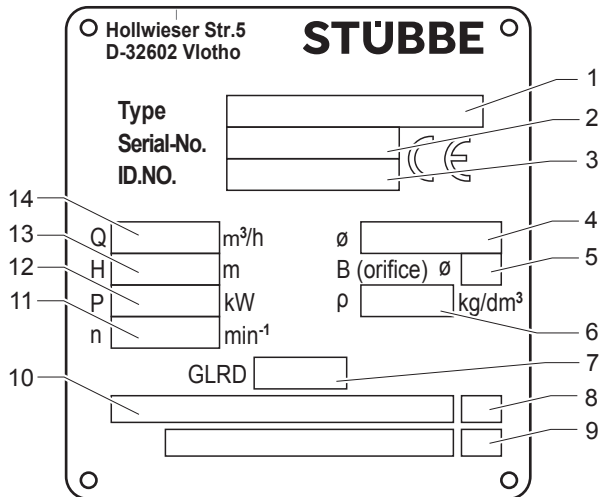

Fig. 1 Name plate (example)

- 1 Pump type
- 2 Serial number
- 3 Identification number
- 4 Impeller diameter (main vanes, back vanes) [mm]
- 5 Diaphragm diameter
- 6 Specific gravity
- 7 Mechanical seal code
- 8 Specifications for shaft sleeve
- 9 Auxiliary seal information
- 10 Shaft seal information
- 11 Rotational speed
- 12 Power consumption of pump / motor
- 13 Differential head
- 14 Flow rate

#### 3.1.2 ATEX type plate

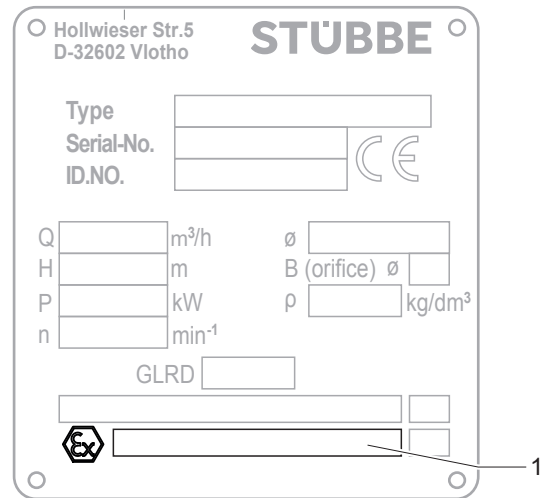

Fig. 2 ATEX type plate (example)

- 1 Explosion protection label

### 3.1.3 Pump type code

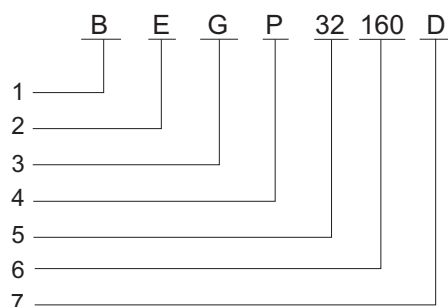

Fig. 3 Pump type code (example)

- 1 Design type
  - **B** – Monobloc pump
- 2 Series
  - **E** – STÜBBE E-CLASS
- 3 Hydraulics
  - **H** – Half-open impeller
  - **G** – Closed impeller
- 4 Material of the volute casing
  - **P** – PP (polypropylene)
  - **E** – UHMW-PE (ultra-high molecular weight low-pressure polyethylene)
  - **D** – PVDF (polyvinylidene fluoride)
  - **T** – PTFE/PFA (polytetrafluoroethylene/perfluoroalkoxy polyme)
  - **H** – UHMW-PE (conductive)
  - **I** – PVDF (conductive)
  - **L** – PTFE/PFA (conductive)
- 5 Diameter discharge nozzle
- 6 Impeller nominal diameter
- 7 Name suffix (optional)
  - **D** – Restricting orifice mounted directly on the discharge nozzle
  - **S** – Special version

### 3.1.4 Mechanical seal type code

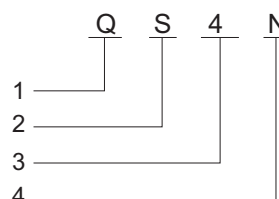

Fig. 4 Mechanical seal type code (example)

- 1 Version
  - **E** – Single-acting mechanical seal
  - **Q** – Single-acting mechanical seal with quench
  - **D** – Double-acting mechanical seal
- 2 Manufacturer of the mechanical seal on the atmosphere side
  - **S** – STÜBBE
- 3 Type
  - **4** – UV4 (single-acting mechanical seal)
- 4 Flushing connection
  - **N** – Standard version (double-acting mechanical seal, single-acting mechanical seal without flushing)
  - **S** – Standstill flushing

## 3.2 Description

### 3.2.1 BE pump

Horizontal, single-stage centrifugal chemical plastic pump with mechanical seal in monobloc design (not self-priming).

- The replaceable pump casing parts are made of thick-walled, vacuum-resistant, corrosion- and diffusion-resistant solid plastic
- The universal shaft is suitable for use with all available mechanical seals
- Slotted pump shaft mounted on the shaft journal of the motor for clamping by means of clamping screws
- Self-developed mechanical seal kit (single-acting)
- 2 variants of connections:
  - Flange
  - Socket (only with normal size 32)

### 3.2.2 BE ATEX pump

Pumps and complete units with separate approval can be used as category 2G or 3G equipment in potentially explosive atmospheres (ATEX zone 1 and zone 2). However, this requires the use of conductive plastics.

The ATEX conformity is marked on the type plate (→ Fig. 2 ATEX type plate (example), Page 10). The declaration of conformity according to the EU explosion protection directive 2014/34/EU must also be available.

## 3.3 Assembly

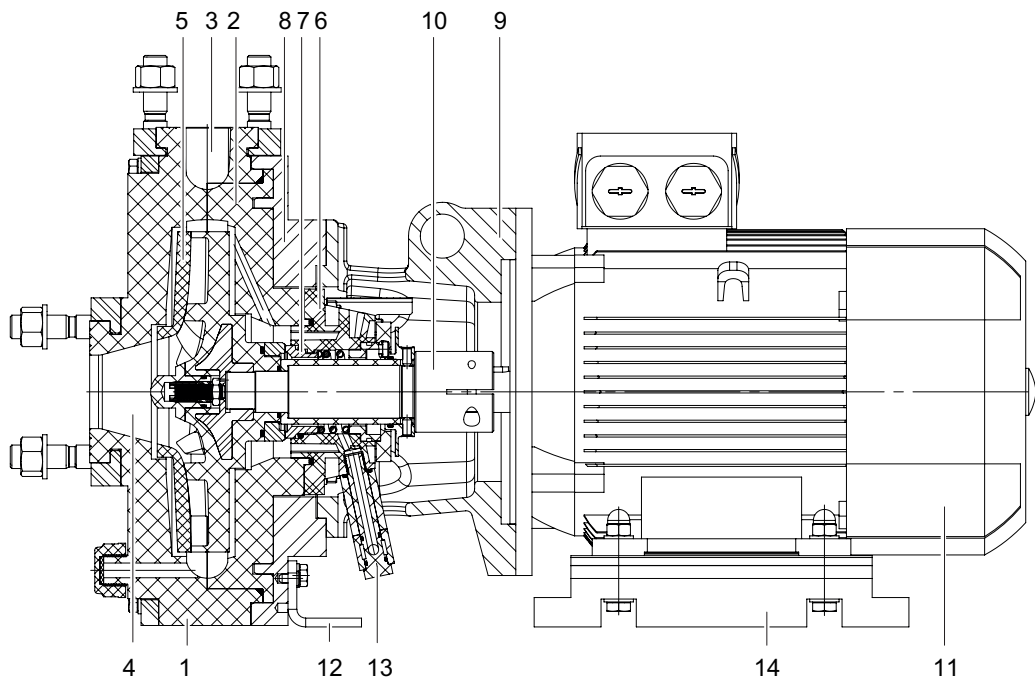

Fig. 5 Assembly (connection variant flange connection)

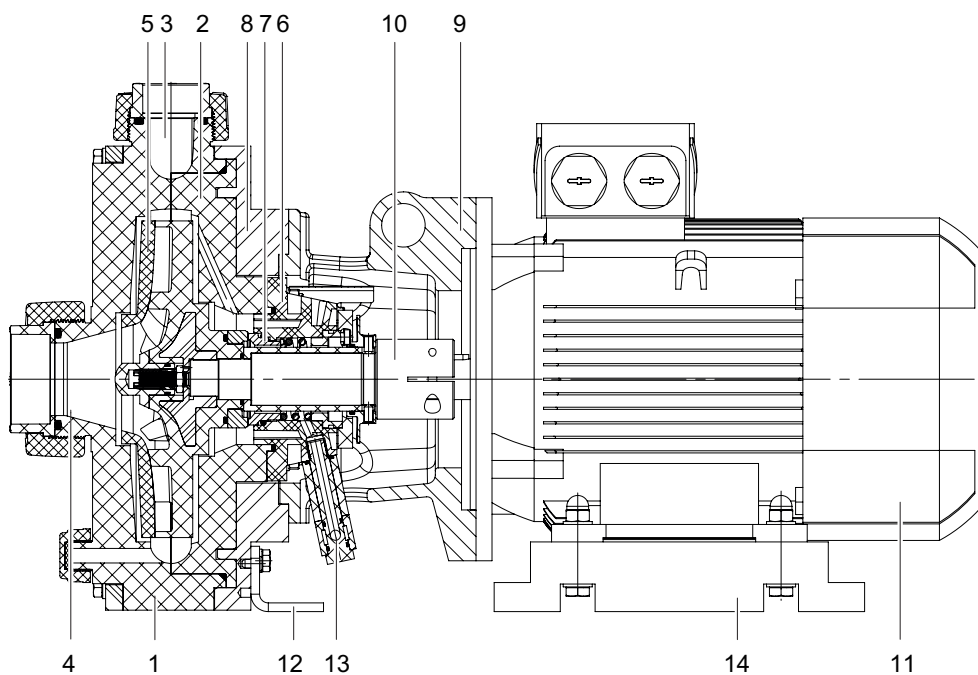

Fig. 6 Assembly (connection variant screw connection)

- |   |                  |    |                 |    |                      |
|---|------------------|----|-----------------|----|----------------------|
| 1 | Volute casing    | 6  | Seal casing     | 11 | Motor                |
| 2 | Casing cover     | 7  | Mechanical seal | 12 | Support foot         |
| 3 | Discharge nozzle | 8  | Ring casing     | 13 | Leakage connection   |
| 4 | Suction nozzle   | 9  | Drive lantern   | 14 | Motor mounting plate |
| 5 | Impeller         | 10 | Pump shaft      |    |                      |

### 3.4 Mechanical seals - single-acting mechanical seal type STÜBBE UV4

- Nearly universal chemical resistance
- Robust spring-loaded mechanical seal in „FGD"-design
- Up to 100 °C and up to 3 bar(g) inlet pressure
- Up to 6 bar(g) static pressure
- Material properties of the components:
  - Counter ring made of SSiC
  - Sliding ring made of SSiC / carbon
  - Halar-coated spring made of stainless steel
  - Sturdy seal casing made of fibre-reinforced plastic
- With sliding ring and counter ring, moments are transmitted via a robust plastic-compatible drive (breakaway torque in the case of adhesion and adhesion forces)
- Depending on requirements, the following versions are available:
  - Internal flushing (product flushing)
  - Internal flushing and quench
  - Standstill flushing (flushing after use)

#### 3.4.1 Version with internal flushing (product flushing) – API plan 01, type ES4N

- For uncritical applications
- Flushing of the mechanical seal with pumped medium

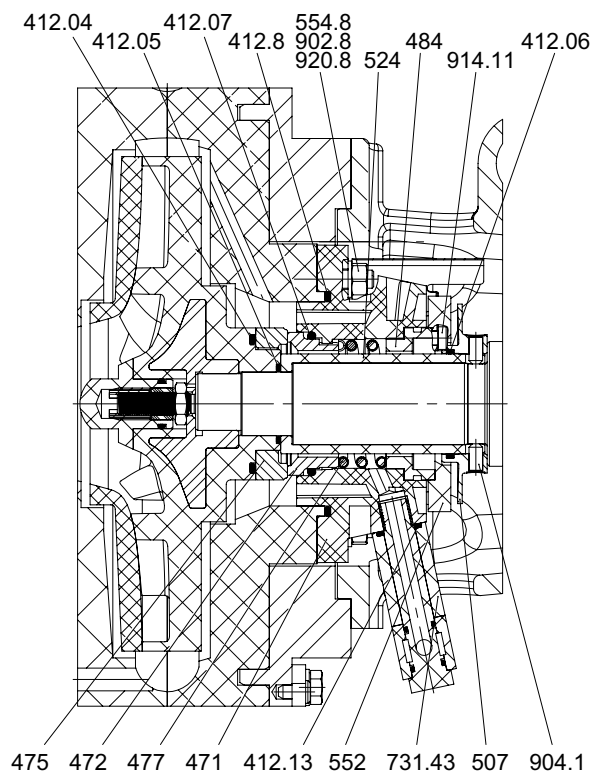

Fig. 7 Single-acting mechanical seal, version internal flushing

#### 3.4.2 Version with internal flushing and quenching – API plan 62, type QS4N

- Sealing of the seal casing (471) on the atmosphere side by means of a radial rotary shaft seal (421.3)
- The hollow space thus created is supplied with quench medium (e.g. deionized water):
  - Quench medium is limited to 30 l / h at pressures between 0.8 and 8 bar by built-in flow limiter (ensure free discharge of quench medium, maximum pressure in quench chamber 0.5 bar [g])
  - Prevents crystallization on the mechanical seal
  - Protection against overheating of the mechanical seal in the event of negative pressure in the area of the rotary shaft seal
  - Can also be used in the stand quench version (with quench container, quench liquid in the circuit, **without** flow limiter)

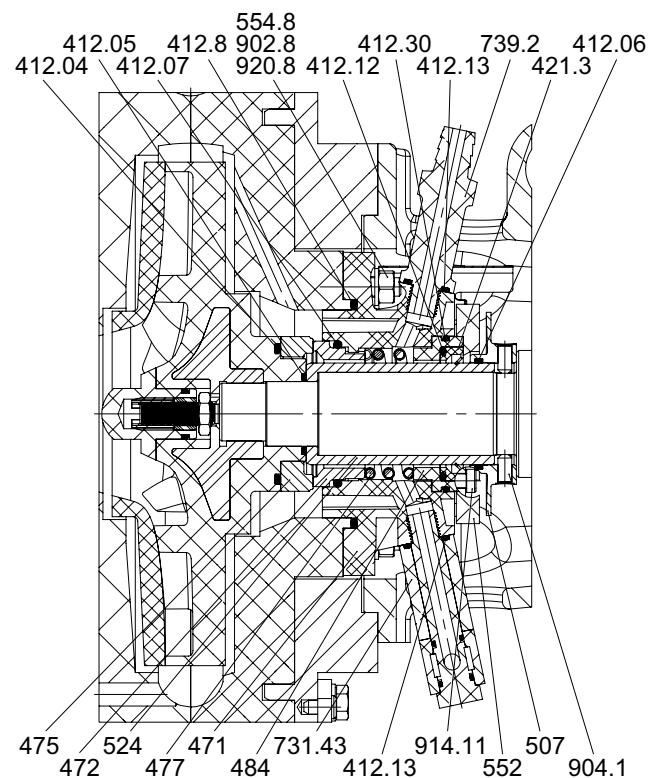

Fig. 8 single-acting mechanical seal, version internal flushing and quench

### 3.4.3 Version with standstill flushing (flushing after use) – API plan 32, type ES4S

- Can be used in the following operating situations or applications:
  - In the event of deposits of solids or adhesions in the pump interior
  - Pumping of solids-laden media, where for process reasons the use of flushing media is prohibited
- Flushes the mechanical seal with clean flushing medium (such as water) immediately before the pump is switched off or immediately after it is switched off (aprox. 50-100 l during the course of approx. 1-2 min. flushing period)
- Prevents sedimentation when the pump is stationary, and crystallization within the pump in the area of the mechanical seal
- The flushing medium will mix with the pumped medium. For certain processes, such as evaporation processes or applications involving sulfuric acid, the use of flushing media is prohibited

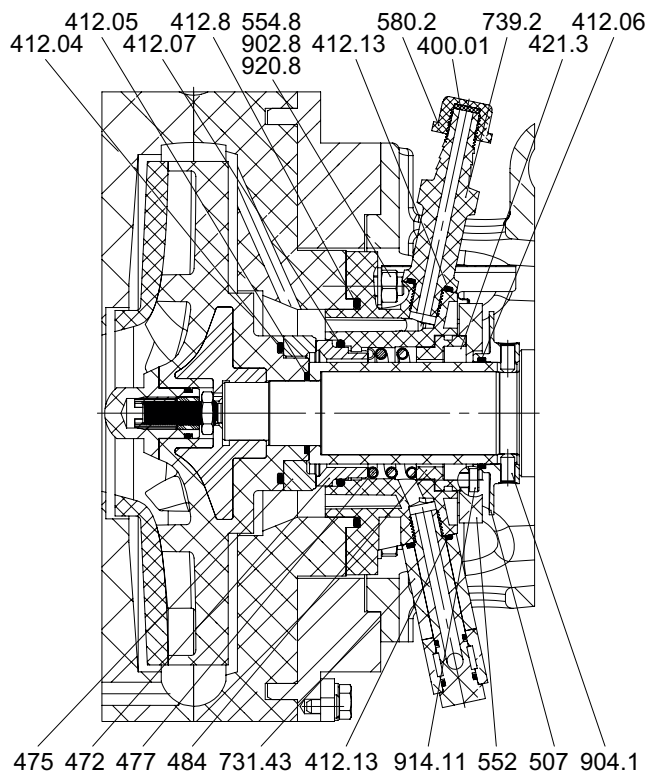



Fig. 9 Single-acting mechanical seal with standstill flushing

## 4 Transport, Storage and Disposal

### 4.1 Transport

 The user/owner is responsible for the transport of the pump.

 Weight specifications (→ documents for the particular order)

#### 4.1.1 Unpacking and inspection on delivery

1. Unpack the pump/pump assembly upon delivery and inspect it for transport damage.
2. Check completeness and accuracy of delivery.
3. Ensure that the information on the name plate agrees with the order/design data.
4. Report any transportation damage to the manufacturer immediately.
5. Dispose of packaging material according to local regulations.

#### 4.1.2 Lifting

 **DANGER**

**Death or limbs crushed as a result transported items falling over!**

- ▶ Use lifting gear appropriate for the total weight to be transported.
- ▶ Attach lifting gear in accordance with the following diagram.
- ▶ Never use the lifting eye of the motor as the attachment point for lifting the entire pump (the lifting eye of the motor may be used for securing a pump assembly with a high center of gravity against being knocked over).
- ▶ Do not stand under suspended loads.
- ▶ Do not incline the pump more than 10°.

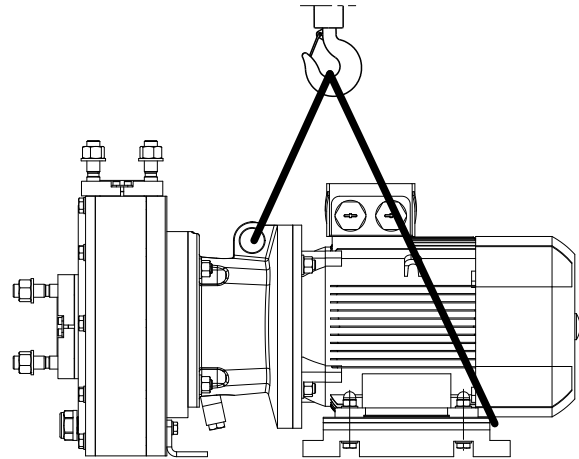

Fig. 10 Attaching lifting gear to the pump unit

1. Attach lifting gear in accordance with the following diagrams:
  - Crane eyes on motor lantern
  - Slip below the fan cover
2. Lift the pump/pump unit appropriately.

### 4.2 Storage

#### NOTE

##### Material damage due to inappropriate storage!

- ▶ Store the pump properly.
- 
1. Seal all openings with blind flanges, blind plugs or plastic covers.
  2. Make sure the storage room meets the following conditions:
    - Dry
    - Frost-free
    - Vibration-free
    - UV protected
  3. Overrun the shaft every three months, but no later than before commissioning.
  4. Make sure the shaft and bearing change their rotational position in the process.

### 4.3 Disposal

-  Plastic parts can be contaminated by poisonous or radioactive pumped liquids to such an extent that cleaning will be insufficient.

#### WARNING

##### Risk of poisoning and environmental damage by the pumped liquid!

- ▶ Use personal protective equipment when carrying out any work on the pump.
  - ▶ Prior to the disposal of the pump:
    - Collect leaking liquid and dispose of it in accordance with local regulations.
    - Neutralize residues of pumped liquid in the pump.
  - ▶ Remove plastic parts and damage them in accordance with local regulations.
- 
- ▶ Dispose of the pump in accordance with local regulations.



## 5 Installation and connection

 For pumps in potentially explosive atmospheres (→ ATEX additional manual).

---

### NOTE

#### Material damage due to distortion or passage of electrical current in the bearing!

- ▶ Do not make any structural modifications to the pump assembly or pump casing.
- ▶ Do not carry out any welding work on the pump assembly or pump casing.

---

### NOTE

#### Material damage caused by dirt!

- ▶ Do not remove the transport seals until immediately before installing the pump.
- ▶ Do not remove any covers or transport and sealing covers until immediately before connecting the pipes to the pump.

### 5.1 Preparing for installation

#### 5.1.1 Check operating conditions

- ▶ Ensure the required operating conditions are met:
  - Resistance of the materials of the housing and seals to the medium (→ resistance list).
  - Required ambient conditions (→ [9.2.1 Ambient conditions, Page 35](#)).
  - Operational limits (→ [9.2.6 Operational limits, Page 38](#)).

#### 5.1.2 Preparing the installation site

- ▶ Ensure the installation site meets the following conditions:
  - Pump is freely accessible from all sides
  - Sufficient space for the installation/removal of the pipes and for maintenance and repair work, especially for the removal and installation of the pump and the motor
  - Pump not exposed to external vibration (damage to bearings)
  - No corrosive exposure
  - Frost protection

#### 5.1.3 Prepare foundation and surface

✓ Aids, tools, materials:

- Steel shims
- Spirit level

 Installation options:

- With concrete foundation
- With steel foundation frames
- Without foundation

1. Ensure the foundation and surface meet the following conditions:
  - Level and horizontal
  - Clean (no oil, dust or other impurities)
  - Capable of bearing the weight of the pump assembly and all operating forces
  - Stability of the pump ensured
  - With concrete foundation: Normal concrete of strength class X0 in accordance with DIN EN 206
2. Clean pump sump carefully.

### 5.2 Installing with foundation

---

### NOTE

#### Material damage due to distortion of base plate!

- ▶ Position the base plate as follows on the foundation and attach.

#### 5.2.1 Place pump unit on the foundation

✓ Aids, tools, materials:

- Anchor bolts
- Steel shims
- Mortar casting compound, no shrinkage
- Spirit level

1. Lifting the pump unit (→ [4.1 Transport, Page 15](#)).
2. Hook anchor bolts in the mounting holes on the base plate from below.

 Observe manufacturers information when using the fixing material.

3. Position the pump unit on the foundation. When doing so lower the anchor bolts into the prepared anchoring holes.

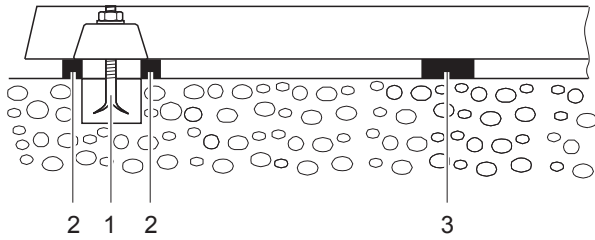



Fig. 11 Installation with foundation

4. Align the pump for height and system dimensions using steel shims as follows:
  - Arrange steel shims (2) to the left and right of each anchor bolt (1).
  - If the distance between the anchoring holes is > 750 mm, then arrange additional steel shims (3) on each side of the base plate in the center.
5. Ensure that the base plate lies flat against steel shims.
6. Check the permissible height deviation (1mm/m) using a mechanical spirit level in a longitudinal and a transverse direction.
7. Repeat the procedure until the base plate is correctly aligned.

### 5.2.2 Attaching pump unit

 Filling the base plate with mortar casting compound improves dampening properties.

1. Fill the anchoring holes with mortar casting compound.
2. When the mortar casting compound has set, bolt the base plate at three points to the specified tightening torque.
3. Before tightening the remaining bolts, arrange shims next to every bolt to even out any irregularities in the mounting surface.

## 5.3 Installing without foundation

 Only allowed if pump is provided for installation without foundation (→ order data sheet).

Attachment methods must be designed so that undesirable displacement of the pump is prevented.

When installed on machine feet, the operational stability is achieved by the weight of the pump itself and the rigidity of the attached pipework. Pipework must be installed so that it is not stressed.

For a pump unit set up insulated, such as for an installation without foundation, provide separate earthing.

✓ Aids, tools, materials:

- Impact wrench
- Spirit level

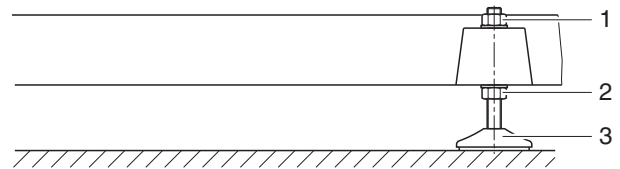

Fig. 12 Installation without foundation

1. Lifting the pump unit (→ 4.1.2 Lifting, Page 15).
2. Mount all leveling feet as illustrated.
3. Place pump unit on subsurface.
4. Set height of the base plate via leveling feet as illustrated above:
  - Use impact wrench to secure hexagonal bolt on leveling foot (3).
  - Undo the hexagon nut (1).
  - Set height by turning the hexagonal nut (2).
  - Tighten hexagonal nut (1).
  - Check the permissible height deviation (1mm/m) using a mechanical spirit level in a longitudinal and a transverse direction.
  - Repeat the procedure until the base plate is correctly aligned.

## 5.4 Planning the electrical system

- ▶ Ensure the following in the electrical supply to the pump unit:
  - Provide a device for isolating from the power supply.
  - The device for isolating from the power supply must be capable of their actuated during normal operation and also in an emergency (emergency stop switch). The emergency stop switch must satisfy ISO 13850.
  - If the pump unit stops due to a power failure it must be protected against automatic restarting (on restoration of power).
  - Install a motor protection switch to act as a cut-out in the event of overheating and adjust it in accordance with the particulars on the motor nameplate.
  - If a frequency inverter is to be used at low speeds, check whether an external cooler may be necessary.
  - The encapsulation of the control systems must satisfy the protection classes specified in EN 60529.

## 5.5 Connecting the pump

### 5.5.1 Making the electrical connections to the motor

 Follow the instructions of the motor manufacturer.

#### DANGER

##### Risk of electrocution!

- ▶ All electrical work must be carried out only by qualified electricians.
- ▶ Before all work on the electrical system, disconnect the motor from the mains and secure against being switched back on again.

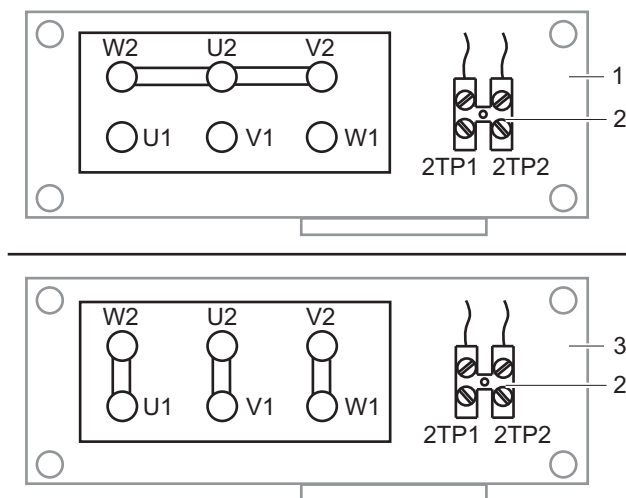
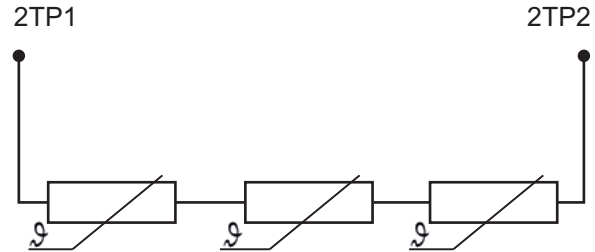

Fig. 13 Connecting the motor

- 1 Star connection
- 2 Connecting the PTC thermistor
- 3 Delta connection

1. Connect the motor as shown in the circuit diagram, as a delta connection (1) or a star connection (3).
2. Make sure no danger arises due to electric power.
3. Install an EMERGENCY STOP switch.



4. Connect the PTC thermistor (2) to the motor protector:
  - Test voltage 2.5 V
5. Connect the optional standstill heating for the motor. When making the electrical connections, make sure that the voltage matches that on the name plate (motor) and work to the terminal diagram provided.

### 5.5.2 Check direction of rotation

#### DANGER

##### Risk of electrocution!

- ▶ All electrical work must be carried out only by qualified electricians.
- ▶ Before all work on the electrical system, disconnect the motor from the mains and secure against being switched back on again.

#### DANGER

##### Danger to life from rotating parts!

- ▶ Use personal protective equipment when carrying out any work on the pump.
- ▶ Maintain an adequate distance from rotating parts.
- ▶ After testing disconnect the motor and secure it against reconnection.

1. Switch on motor for max. 2 seconds and switch it off again immediately.
2. Check whether the sense of rotation of the motor matches the direction of rotation on the fan impeller.
3. If the sense of rotation is different: Change over the two phases (→ 5.5.1 Making the electrical connections to the motor, Page 19).
4. Disconnect the motor from the mains and secure it against being switched back on again.

## 5.6 Planning pipelines

**i** Water hammer may damage the pump or the system. Plan the pipes and fittings to prevent water hammer from occurring.

In order to avoid pressure shocks, using slow-closing fittings and install expansion joints or pulsation dampers.

### 5.6.1 Specifying supports and flange connections

#### NOTE

**Material damage due to excessive forces and torques on the pump!**

► Ensure pipe connection without stress.

1. Plan pipes safely:
  - No pulling or thrusting forces
  - No bending moments
  - Adjust for changes in length due to temperature changes (compensators, expansion shanks)
2. Support pipes in front of the pump.
3. Ensure the pipe supports have permanent low-friction properties and do not seize up due to corrosion.

### 5.6.2 Specifying nominal widths

**i** Keep the flow resistance in the pipes as low as possible.

1. Ensure nominal suction pipe width is not smaller than the nominal suction flange width.
  - Avoid flow velocities > 2 m/s.
  - Recommended flow velocity < 1 m/s
  - Maximum flow velocity = 9 m/s
2. Ensure the nominal pressure line width is not smaller than the nominal pressure flange width.
  - Avoid flow rate > 3 m/s in plastic pipes.
  - Recommended flow velocity < 3 m/s
  - Maximum flow velocity = 12 m/s
  - Install a vent valve, check valve and pressure gauge in pressure line just behind the discharge flange.

### 5.6.3 Specifying pipe lengths

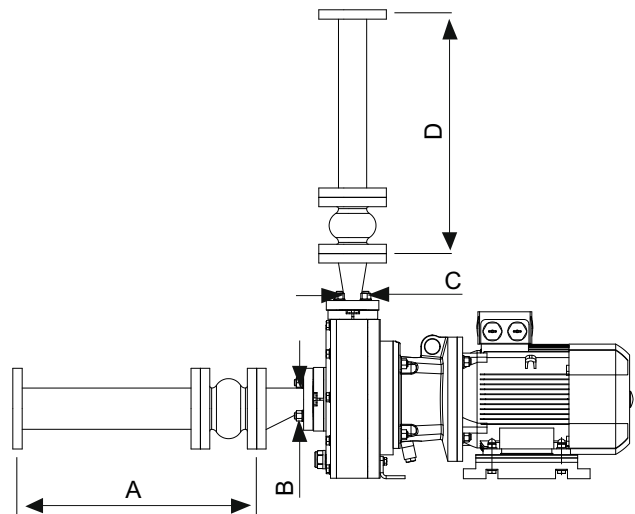

Fig. 14 Straight pipe lengths in front and after the pumps (recommended)

- A > 5x DN<sub>s</sub>
- B DN<sub>s</sub>
- C DN<sub>d</sub>
- D > 5x DN<sub>d</sub>

► Observe recommended minimum values when installing the pump.

**i** Suction side: Shorter lengths are possible, but may limit hydraulic performance data.

Pressure side: Shorter lengths are possible, but may result in increased noise development.

### 5.6.4 Provide self-priming container

**i** A self-priming container can be used to make the pump self-priming.

1. Select container volumes according to the size of the pump.
2. Clean containers carefully prior to commissioning or initial filling.

### 5.6.5 Optimizing changes of cross section and direction

1. Avoid radii of curvature of less than 1.5 times the nominal pipe diameter.
2. Avoid abrupt changes of cross-section along the piping.

### 5.6.6 Planning expansion joints

- ✓ Pipe diameter reducer installed with a smaller bore than the pump port
- Install expansion joints at the larger end of the pipe diameter reducer.

## 5.6.7 Planning a non-return valve

If the non-return valve is installed at a distance  $< 0.5$  m from the discharge flange, air cushions can occur upstream of the non-return valve when the pump is being filled, which prevent a smooth start-up.

1. Install the non-return valve at a distance  $\geq 0.5$  m from the discharge flange, so that at start-up the pump can be correctly filled with the medium being conveyed.
2. To ensure suitable venting, install a bypass pipe with a shut-off valve at the non-return valve.

## 5.6.8 Planning venting facilities and pressure gauges

- ▶ Provide venting facilities and pressure gauges between the discharge flange of the pump and the first shut-off valve.

## 5.6.9 Discharging leaks

### WARNING

**Risk of injury and poisoning due to hazardous pumped liquids!**

- ▶ Safely collect any leaking pumped liquid, then discharge and dispose of it in accordance with environmental regulations.

1. Connect the leakage connection to allow secure drainage of leaked medium.
2. Provide equipment for collecting and discharging leaking liquids.
3. Ensure the free discharge of leaking liquids.

## 5.6.10 Providing safety and control devices (recommended)

### Avoid contamination

1. Install filters in the suction pipe.
2. Install a differential pressure gauge with contact manometer to monitor contamination.

### Avoid reverse running

1. Install a non-return valve in the discharge pipework (close to the shut-off valve) to ensure that the pumped medium does not flow back after the pump is switched off.
2. In order to enable venting, include vent connection between discharge flanges and non-return valve.

### Make provisions for isolating and shutting off the pipes

 For maintenance and repair work.

- ▶ Provide shut-off devices in the suction pipe and pressure line.

## Allow measurements of the operating conditions

1. Provide pressure gauge in the suction pipe and pressure line for pressure measurement.
2. Provide motorside load monitors (over and underload).
3. Provide pressure measurement on the pump side.

## Provide dry run protection

- ▶ In order to protect the pump from dry running and resulting damage
  - Provide dry run protection
  - e.g. STÜBBE PTM pressure and temperature monitoring sensor

## Provide an overpressure protection

 Overpressure protection is required for operation in explosive areas (→ ATEX additional manual).

- ▶ Provide an overpressure protection.

## 5.7 Connecting the pipes

### NOTE

**Material damage due to excessive forces and torques on the pump!**

- ▶ Ensure pipe connection without stress.

### 5.7.1 Keeping the piping clean

### NOTE

**Material damage due to impurities in the pump!**

- ▶ Make sure no impurities can enter the pump.

1. Clean all piping parts and fittings prior to assembly.
2. Flush all pipes carefully with neutral medium.
3. Ensure no flange seals protrude inwards.
4. Remove any blind flanges, plugs, protective foils and/or protective paint from the flanges.

### 5.7.2 Installing auxiliary pipes

 Observe manufacturer information for any auxiliary systems present.

1. Connect the auxiliary pipes to the auxiliary connections so that they are stress-free and do not leak.
2. Avoid formation of air pockets: Run the pipes with a continuous slope up to the pump.

### 5.7.3 Installing the suction pipework

1. Remove the transport and sealing covers from the pump.
2. Fit suction pipe stress-free and sealed (→ 9.2.3 Flange tightening torques, Page 38).
3. Ensure no seals protrude inwards.
4. During suction operation, proceed as follows:
  - As far as possible, avoid installing a foot valve in the suction pipework
  - Installation of a separate evacuation device or self-priming container with a non-return valve in the discharge pipework is recommended

### 5.7.4 Installing the pressure pipe

1. Remove the transport and sealing covers from the pump.
2. Fit the pressure line stress-free and sealed (→ 9.2.3 Flange tightening torques, Page 38).
3. Ensure no seals protrude inwards.

### 5.7.5 Inspection for stress-free pipe connections

- ✓ Piping installed and cooled down
1. Disconnect the pipe connecting flanges from the pump.
  2. Check whether the pipes can be moved freely in all directions within the expected range of expansion:
    - Nominal width < 150 mm: by hand
    - Nominal width > 150 mm: with a small lever
  3. Make sure the flange surfaces are parallel.
  4. Reconnect the pipe connecting flanges to the pump.
  5. If present, check support foot for stress.

## 5.8 Performing the hydrostatic test

-  Only necessary if the entire system needs to be tested under pressure.

---

### NOTE

---

#### Material damage due to bursting of pump casing!

- ▶ Testing pressure must not exceed the permissible pump pressure (→ documents for the particular order).
- ▶ Make sure the testing pressure does not exceed the permissible pump pressure.
  - If necessary, do not perform pressure test on the pump.

Max. test pressure of the mechanical seal UV4 = 4 bar.

## 6 Operation

 For pumps in potentially explosive atmospheres (→ ATEX additional manual).

### 6.1 Preparing for commissioning

#### 6.1.1 Check downtimes

▶ Check downtimes (→ [6.4 Restoring the pump to service, Page 24](#)).

#### 6.1.2 Filling and bleeding

#### WARNING

#### Risk of injury and poisoning due to hazardous pumped liquids!

- ▶ Use protective equipment for any work on the pump.
- ▶ Safely collect the fluid and dispose of it in accordance with environmental regulations.

#### NOTE

#### Material damage as a result of dry running!

▶ Make sure the pump is filled properly.

1. If present, fill and vent self-priming container with fluid.
2. Open the suction-side fitting.
3. Open the pressure-side fitting.
4. Fill pump and suction pipe with fluid.
5. Verify that no pipe connections are leaking.

#### 6.1.3 Preparing auxiliary systems (if present)

 The manufacturer accepts no liability for damage arising due to the installation or use of a third party or non-approved auxiliary system.

#### Sealing systems

1. Ensure that the sealing medium is appropriate to mix with the pumped medium.
2. Ascertain the sealing system (→ order-specific documentation).
3. Install the sealing system (→ manufacturer information).
4. Ensure the necessary parameters for the sealing system (→ manufacturer information).

## 6.2 Commissioning

### 6.2.1 Switching on

- ✓ Pump set up and connected properly
- ✓ Direction of rotation checked
- ✓ Motor set up and connected properly
- ✓ All connections stress-free and sealed
- ✓ All safety equipment installed and tested for functionality
- ✓ Pump prepared, filled and vented correctly
- ✓ Auxiliary systems switched on if present

#### DANGER

#### Risk of injury due to running pump!

- ▶ Do not touch the pump when it is running.
- ▶ Do not carry out any work on the pump when it is running.
- ▶ Allow the pump to cool down completely before starting any work.

#### DANGER

#### Risk of injury and poisoning due to pumped liquid spraying out!

- ▶ Use personal protective equipment when carrying out any work on the pump.

#### NOTE

#### Risk of cavitation if suction flow is restricted!

- ▶ Open the suction-side fitting and do not use it to regulate the flow.
- ▶ Do not open the pressure-side fitting beyond the operating point.

#### NOTE

#### Material damage due to overheating!

- ▶ Do not operate the pump for long periods with the pressure-side fitting closed.
- ▶ Observe the minimum flow rate (→ [Tab. 14 Volumetric flow of the pumped medium, Page 38](#)).

#### NOTE

#### Material damage as a result of dry running!

▶ Ensure that the pump is properly filled and ventilated.

1. Turn on auxiliary systems (if present).
2. Open the suction-side fitting.
3. Close the pressure-side fitting.

4. Switch on the motor and check it for smooth running.
5. Once the motor has reached its nominal speed, open the pressure-side fitting slowly until the operating point is reached.
6. After the initial stress due to the pressure and operating temperature, check that the pump is not leaking.

### 6.2.2 Switching off

- ✓ Pressure-side fitting closed (recommended)

#### **WARNING**

##### Risk of injury due to hot pump parts!

- ▶ Use personal protective equipment when carrying out any work on the pump.
- 
1. Switch off motor.
  2. Check all connecting bolts and tighten them if necessary (only after initial commissioning).

### 6.3 Shutting down the pump

#### **DANGER**

##### Risk of injury due to running pump!

- ▶ Do not touch the pump when it is running.
- ▶ Do not carry out any work on the pump when it is running.
- ▶ Before all installation and maintenance work, disconnect the motor from the mains and secure it against being switched back on again.

#### **DANGER**

##### Risk of electrocution!

- ▶ All electrical work must be carried out only by qualified electricians.
- ▶ Before all work on the electrical system, disconnect the motor from the mains and secure against being switched back on again.

#### **WARNING**

##### Risk of injury and poisoning due to hazardous pumped liquids!

- ▶ Use protective equipment for any work on the pump.
- ▶ Collect leaking liquid safely and damage fitting in accordance with local regulations.

- ▶ Take the following measures whenever the pump is shut down:

Pump is	Action
shut down	▶ Take measures appropriate for the fluid (→ <a href="#">Tab. 4 Measures depending on the behavior of the pumped liquid, Page 24</a> ).
...emptied	▶ Close suction and pressure-side fitting.
...dis-mounted	▶ Isolate the motor from its power supply and secure it against unauthorized switch-on.
...put into storage	▶ Note measures for storage (→ <a href="#">4.2 Storage, Page 16</a> ).

Tab. 3 Measures to be taken if the pump is shut down

Behavior of the pumped liquid	Duration of shutdown (depending on process)	
	Short	Long
Crystallized or polymerized, solids sedimenting	▶ Flush the pump.	▶ Flush the pump.
Solidifying/freezing, non-corrosive	▶ Heat up or empty the pump and containers. 1)	▶ Empty the pump and containers.
Solidifying/freezing, corrosive	▶ Heat up or empty the pump and containers. 1)	▶ Empty the pump and containers.
Remains liquid, non-corrosive	–	–
Remains liquid, corrosive	–	▶ Empty the pump and containers.

Tab. 4 Measures depending on the behavior of the pumped liquid

- 1) Observe max. permissible operating temperature.

### 6.4 Restoring the pump to service

1. Complete all steps as for commissioning (→ [6.2 Commissioning, Page 23](#)).
2. If the pump is shut down for over 1 year, replace the elastomer seals (O-rings, shaft sealing rings).
3. For breaks in operations > 2 years, check the mechanical seal.



## 7 Maintenance

 For pumps in potentially explosive atmospheres (→ ATEX additional manual).

 Trained service technicians are available for fitting and repair work. Submit evidence of conveyed medium on request (DIN safety data sheet or safety certificate).

### 7.1 Inspections

 The inspection intervals depend on the operational strain on the pump.

#### DANGER

##### Risk of injury due to running pump!

- ▶ Do not touch the pump when it is running.
- ▶ Do not carry out any work on the pump when it is running.

#### WARNING

##### Risk of injury and poisoning due to hazardous pumped liquids!

- ▶ Use personal protective equipment when carrying out any work on the pump.

1. Check at appropriate intervals:
  - Adherence to the minimum flow rate (→ [Tab. 14 Volumetric flow of the pumped medium, Page 38](#)).
  - Normal operating conditions unchanged
2. For trouble-free operation, always ensure the following:
  - No dry running
  - No leaks
  - No cavitation
  - Suction side open gate valves
  - Free and clean filters
  - Sufficient pump inlet pressure
  - No unusual running noises or vibrations

## 7.2 Servicing

#### DANGER

##### Risk of injury due to running pump!

- ▶ Do not touch the pump when it is running.
- ▶ Do not carry out any work on the pump when it is running.
- ▶ For all installation and maintenance work, disconnect the motor from the mains and lock.

#### DANGER

##### Risk of electrocution!

- ▶ All electrical work must be carried out only by qualified electricians.

#### WARNING

##### Risk of injury and poisoning due to hazardous or hot fluid!

- ▶ Use protective equipment for any work on the pump.
- ▶ Allow the pump to cool down completely before commencing any work.
- ▶ Make sure the pump is depressurized.
- ▶ Empty the pump, safely collect the pumped liquid and damage it in accordance with environmental rules and requirements.

### 7.2.1 Maintenance in accordance with maintenance schedule

- ▶ Perform maintenance work in accordance with the maintenance schedule.

Designation	Interval	Maintenance
Pump assembly	daily	<ul style="list-style-type: none"> <li>▶ Check for increased noise development.</li> <li>▶ Check for vibration.</li> <li>▶ Pay attention to increased current consumption of the motor.</li> <li>▶ Check that the anchor bolts are correctly seated.</li> <li>▶ Check for oxidation.</li> <li>▶ Check for leakage and crystallization.</li> <li>▶ Check the leakage tray and splash guard.</li> <li>▶ If leakage occurs, exchange defective parts immediately.               <ul style="list-style-type: none"> <li>– Mechanical seal (→ other applicable documents).</li> </ul> </li> </ul>
Self priming container (if present)	daily	<ul style="list-style-type: none"> <li>▶ Check filling level.</li> </ul>
Continuous quenching vessel (if applicable)	daily	<ul style="list-style-type: none"> <li>▶ Check the filling level and refill quench medium if necessary. If the pumped medium is too high, change the quench medium.</li> </ul>
Leakage connection	daily	<ul style="list-style-type: none"> <li>▶ Check for leaking pumped liquid.</li> </ul>
Undoable screwed connections	weekly	<ul style="list-style-type: none"> <li>▶ Check for tight fitting.</li> </ul>
Mechanical seals	Yearly	<ul style="list-style-type: none"> <li>▶ Check them for leakage and replace them if necessary.</li> </ul>
Pump assembly	as required	<ul style="list-style-type: none"> <li>▶ Cleaning.</li> </ul>

Tab. 5 Maintenance schedule

## 7.3 Dismounting

### DANGER

#### Risk of injury due to running pump!

- ▶ Do not touch the pump when it is running.
- ▶ Do not carry out any work on the pump when it is running.
- ▶ Before all installation and maintenance work, disconnect the motor from the mains and secure it against being switched back on again.

### DANGER

#### Risk of electrocution!

- ▶ All electrical work must be carried out only by qualified electricians.
- ▶ Before all work on the electrical system, disconnect the motor from the mains and secure against being switched back on again.

### WARNING

#### Risk of injury and poisoning due to hazardous or hot fluid!

- ▶ Use personal protective equipment when carrying out any work on the pump.
- ▶ Allow the pump to cool completely before commencing any work.
- ▶ Make sure the pump is depressurized.
- ▶ Empty the pump, safely collect the pumped liquid and dispose it in accordance with environmental rules and requirements.

### WARNING

#### Risk of injury due to heavy components!

- ▶ Pay attention to the component weight. Lift and transport heavy components using suitable lifting gear.
- ▶ Set down components safely and secure them against overturning or rolling away.

### WARNING

#### Risk of injury during disassembly!

- ▶ Secure the pressure-side gate valve against accidental opening.
- ▶ Wear protective gloves, components can become very sharp-edged due to wear or damage.
- ▶ Remove spring-loaded components carefully (e.g. mechanical seal, stressed bearing, valves etc.), as components can be ejected by the spring stress.
- ▶ Observe the manufacturer's specifications (e.g. for the motor, mechanical seal etc.).

## NOTE

### Material damage due to incorrect dismounting/installation of the pump!

- ▶ Only specialist mechanics should complete dismounting/installation work.

### 7.3.1 Preparations for dismounting

- ✓ Pump is depressurized
- ✓ Pump completely empty, flushed and decontaminated
- ✓ Electrical connections disconnected and motor secured against switch-on
- ✓ Pump cooled down
- ✓ Pressure gauge lines, pressure gauge and fixtures dismounted
- ✓ Any existing flushing lines dismantled

## NOTE

### Material damage, fragile components!

- ▶ Dismount ceramic parts of the plain bearing with care, do not hit or knock.

1. Dismantle the pipes on the suction and pressure side.
2. Remove pump from the system.
3. When dismounting, observe the following:
  - Mark the precise orientation and position of all components before dismounting them.
  - Dismount components concentrically without canting.

## 7.4 Replacement parts and return

1. Have the following information ready to hand when ordering spare parts
  - Device type
  - ID number
  - Nominal pressure and diameter
  - Connection and gasket material
2. Please complete and enclose the document of compliance for returns  
(→ [www.stuebbe.com/en/service/download](http://www.stuebbe.com/en/service/download)).



### 8 Troubleshooting

 For pumps in potentially explosive atmospheres (→ ATEX additional manual).

If faults occur which are not specified in the following table or cannot be traced back to the specified causes, please consult the manufacturer.

Possible faults are identified by a fault number in the table below. This number identifies the respective cause and remedy in the troubleshooting list.

Fault	Number
Pump not pumping	1
Pumping rate insufficient	2
Pumping rate excessive	3
Pumping pressure insufficient	4
Pumping pressure excessive	5
Pump running roughly / pump running noisily / high bearing temperature	6
Pump leaks	7
Excessive motor power uptake	8

Tab. 6 Fault/number assignment

Fault number								Possible cause	Remedy
1	2	3	4	5	6	7	8		
X	-	-	-	-	-	-	-	Intake / suction pipe and/or pressure line closed by fitting	▶ Open the fitting.
X	-	-	-	-	-	-	-	Pump shaft fractured	▶ Repair the pump. ▶ Check the operating conditions.
X	-	-	-	-	-	-	-	Transport and sealing cover still in place	▶ Remove the transport and sealing cover. ▶ Dismount the pump and inspect it for dry-running damage.
X	-	-	-	-	-	-	-	Self-priming container empty / fluid level below the suction pipe intake	▶ Fill the container. ▶ Dismount the pump and inspect it for dry-running damage. ▶ Install monitoring devices.
X	X	-	-	-	-	-	-	Fluid level at inlet too low (pump drawing in air / discontinuous flow)	▶ Dismount the pump and inspect it for dry-running damage. ▶ Install monitoring devices (level sensing cut-off).
X	X	-	X	-	-	-	-	Motor speed too low	▶ Compare the required motor speed with the specifications on the pump type plate. Replace the motor if necessary. ▶ Increase the motor speed if speed control is available.
X	X	-	X	-	X	-	-	Intake / suction pipe inlet, pump or coarse filter / filter clogged or encrusted	▶ Clean the intake / suction pipe inlet, pump or coarse filter / filter
X	X	-	X	-	X	-	-	Air is sucked in	▶ Seal the defective point in the pipework.

Fault number								Possible cause	Remedy
1	2	3	4	5	6	7	8		
X	X	-	X	-	X	-	-	Proportion of gas too high: pump is cavitating	► Consult the manufacturer.
X	X	-	X	-	X	-	-	Pump running in the wrong direction	► Change over any two phases in the motor.
X	X	-	X	-	X	-	-	Impeller out of balance or blocked	► Dismount the pump and inspect it for dry-running damage. ► Clean the impeller.
X	X	-	-	X	X	-	-	Pressure pipe blocked	► Clean the pressure pipe.
X	X	-	-	X	X	-	-	Discharge pipe not fully open	► Open the discharge pipe fitting further.
X	-	-	-	X	-	X	-	Damage due to accumulated medium in pump operation („stewing in its own juice“)	► Repair the pump. ► Check the discharge side (check valve) fittings and discharge pipework / filter for blockages, and resolve the defect.
X	-	-	-	X	-	X	-	Damage due to accumulated medium in pump operation („stewing in its own juice“), because the static delivery height is not being achieved by the pump	► Adapt the pump to the operating conditions.
X	-	-	-	-	X	-	-	Intake/suction pipe and pump not correctly vented or not completely filled	► Completely fill and vent pump and/or pipe.
X	-	-	-	-	X	-	-	Inlet / suction pipe contains air inclusions (cessation of flow due to airlock)	► Install fitting for venting. ► Adjust piping installation.
-	X	-	X	-	-	-	-	Intake / suction pipe not completely open	► Open the fitting.
-	X	-	X	-	-	-	-	Geodetic differential head and/or pipe flow resistances too high	► Remove sediments from the pump and/or pressure pipe. ► Install a larger impeller and consult the manufacturer.
-	X	-	X	-	X	-	-	Cross section of intake / suction pipe too narrow	► Increase cross section. ► Clean encrustation from suction pipe. ► Fully open fitting.
-	X	-	X	-	X	-	-	Suction head too large: $NPSH_{pump}$ is larger than $NPSH_{system}$	► Increase pump inlet pressure. ► Consult the manufacturer.
-	X	-	X	-	X	-	-	Temperature of fluid is too high: pump is cavitating	► Increase pump inlet pressure. ► Lower temperature. ► Contact the manufacturer.
-	X	-	X	-	X	-	-	Pump parts worn	► Replace the worn pump parts.
-	X	-	X	-	X	-	-	Hydraulic parts of the pump dirty, clotted or encrusted	► Dismount the pump. ► Clean the parts.
-	X	-	X	-	X	-	X	Motor running on 2 phases	► Check the fuse and replace it if necessary. ► Check the cable connections and insulation.
-	X	-	X	-	-	-	X	Viscosity or specific gravity of the pumped liquid outside the range specified for the pump	► Consult the manufacturer.
-	X	-	-	X	X	-	-	Pressure-side fitting not opened wide enough	► Open the pressure-side fitting.

Fault number								Possible cause	Remedy
1	2	3	4	5	6	7	8		
-	-	X	X	-	X	-	X	Pressure-side fitting opened too wide	<ul style="list-style-type: none"> <li>▶ Throttle down the flow rate at the pressure-side fitting. Observe the minimum flow rate (→ <a href="#">Tab. 14 Volumetric flow of the pumped medium, Page 38</a>).</li> <li>▶ Machine the impeller down. Consult the manufacturer and adjust the impeller diameter.</li> </ul>
-	-	X	-	X	-	-	-	Viscosity lower than expected	<ul style="list-style-type: none"> <li>▶ Machine the impeller down. Consult the manufacturer and adjust the impeller diameter.</li> </ul>
-	-	X	-	X	X	-	X	Motor speed too high	<ul style="list-style-type: none"> <li>▶ Compare the required motor speed with the specifications on the pump type plate. Replace the motor if necessary.</li> <li>▶ Reduce the motor speed if speed control is available.</li> </ul>
-	-	X	-	X	X	-	X	Impeller diameter too large	<ul style="list-style-type: none"> <li>▶ Throttle down the flow rate at the pressure-side fitting. Observe the minimum flow rate (→ <a href="#">Tab. 14 Volumetric flow of the pumped medium, Page 38</a>).</li> <li>▶ Machine the impeller down. Consult the manufacturer and adjust the impeller diameter.</li> </ul>
-	-	X	-	-	X	-	X	Geodetic differential head, pipe flow resistances and/or other resistances lower than specified	<ul style="list-style-type: none"> <li>▶ Throttle down the flow rate at the pressure-side fitting. Observe the minimum flow rate (→ <a href="#">Tab. 14 Volumetric flow of the pumped medium, Page 38</a>).</li> <li>▶ Machine the impeller down. Consult the manufacturer and adjust the impeller diameter.</li> </ul>
-	-	-	-	X	-	-	-	Flow falls below minimum	<ul style="list-style-type: none"> <li>▶ Increase flow to minimum flow (→ <a href="#">Tab. 14 Volumetric flow of the pumped medium, Page 38</a>).</li> </ul>
-	-	-	-	-	X	-	-	Pump is conveying in part-load or overload range (increased axial forces / radial forces)	<ul style="list-style-type: none"> <li>▶ Operate the pump in the reliable operating range.</li> </ul>
-	-	-	-	-	X	X	X	Pump distorted	<ul style="list-style-type: none"> <li>▶ Check the pipe connections and pump attachment.</li> <li>▶ Check attachment of the support foot.</li> </ul>
-	-	-	-	-	X	-	X	Increased friction due to damage to the pump (foreign bodies)	<ul style="list-style-type: none"> <li>▶ Repair the pump.</li> </ul>
-	-	-	-	-	-	X	-	Material-dependent temperature of the pumped medium is too high	<ul style="list-style-type: none"> <li>▶ Repair the pump.</li> <li>▶ Select the pump material in discussions with the manufacturer.</li> </ul>
-	-	-	-	-	-	X	-	Medium temperature too close to boiling point (single-acting mechanical seal running hot)	<ul style="list-style-type: none"> <li>▶ Repair the pump.</li> <li>▶ Convert the single-acting mechanical seal in consultation with the manufacturer so that it operates with continuous flushing/quenching.</li> </ul>
-	-	-	-	-	-	X	-	Mechanical seal worn	<ul style="list-style-type: none"> <li>▶ Replace mechanical seal.</li> <li>▶ Check pumped medium.</li> </ul>

Fault number								Possible cause	Remedy
1	2	3	4	5	6	7	8		
-	-	-	-	-	-	X	-	Connecting bolts not correctly tightened	▶ Tighten the connecting bolts.
-	-	-	-	-	-	X	-	Faulty housing seal	▶ Replace the housing seal.
-	-	-	-	-	-	-	X	Defective antifriction bearing in motor	▶ Replace the antifriction bearing (→ manufacturer's specifications).

Tab. 7 Troubleshooting list

## 9 Appendix

### 9.1 Replacement parts

#### 9.1.1 Part no. and description

Part no.	Designation
050.1	Flow regulator
060.1	Electric charges deflection sheet
102	Volute casing
103	Ring casing
116	Casing insert
132	Motorflange adapter
161	Casing cover
183	Support foot
211	Pump shaft
233	Impeller
260	Impeller cap
341	Drive lantern
400.01	Gasket
400.02	Gasket
412.01	O-Ring
412.02	O-Ring
412.03	O-Ring
412.04	O-Ring
412.05	O-Ring
412.06	O-Ring
412.07	O-Ring
412.07	O-Ring
412.08	O-Ring
412.08	O-Ring
412.11	O-Ring
412.12	O-Ring
412.13	O-Ring
412.13	O-Ring
412.15	O-Ring
412.27	O-Ring
412.30	O-Ring
421.3	Radial rotary shaft seal
471	Seal casing
472	Sliding ring

Part no.	Designation
474	Thrust ring
475	Counter ring
477	Spring
484	Spring seat
507	Splash ring
510	Clamping ring
515.1	Tension ring
520	Sleeve
524	Shaft sleeve
552	Tension disc
554.1	Washer
554.2	Washer
554.3	Washer
554.4	Washer
554.7	Washer
554.8	Washer
554.27	Washer
554.29	Washer
554.32	Washer
554.36	Washer
562.1	Parallel pin
562.2	Parallel pin
563	Bolt
566.33	Threaded bolt
575.1	Fastening clip
575.2	Fastening clip
580.1	Cap
580.2	Cap
723.1	Flange
723.2	Flange
730.1	Union spigot end for fusion welding
730.2	Union spigot end for fusion welding
731.1	Union nut
731.2	Union nut
731.43	Screw fitting
739.1	Hose nozzle
739.2	Hose nozzle



Part no.	Designation
739.3	Hose nozzle
801	Flange motor
895.1	Mounting plate
901.3	Hex screw
901.7	Hex screw
901.32	Hex screw
902.1	Stud bolt
902.2	Stud bolt
902.4	Stud bolt
902.8	Stud bolt
902.36	Stud bolt
904.1	Thread pin
904.1	Thread pin
914.1	Cylinder screw
914.2	Cylinder screw
914.7	Cylinder screw
914.11	Cylinder screw
914.37	Cylinder screw
914.40	Cylinder screw
916.4	Plug
920.1	Hex nut
920.2	Hex nut
920.4	Hex nut
920.8	Hex nut
920.32	Hex nut
920.33	Hex nut
920.36	Hex nut
920.42	Hex nut

Tab. 8 Designation of components according to part numbers

## 9.1.2 Sectional drawing

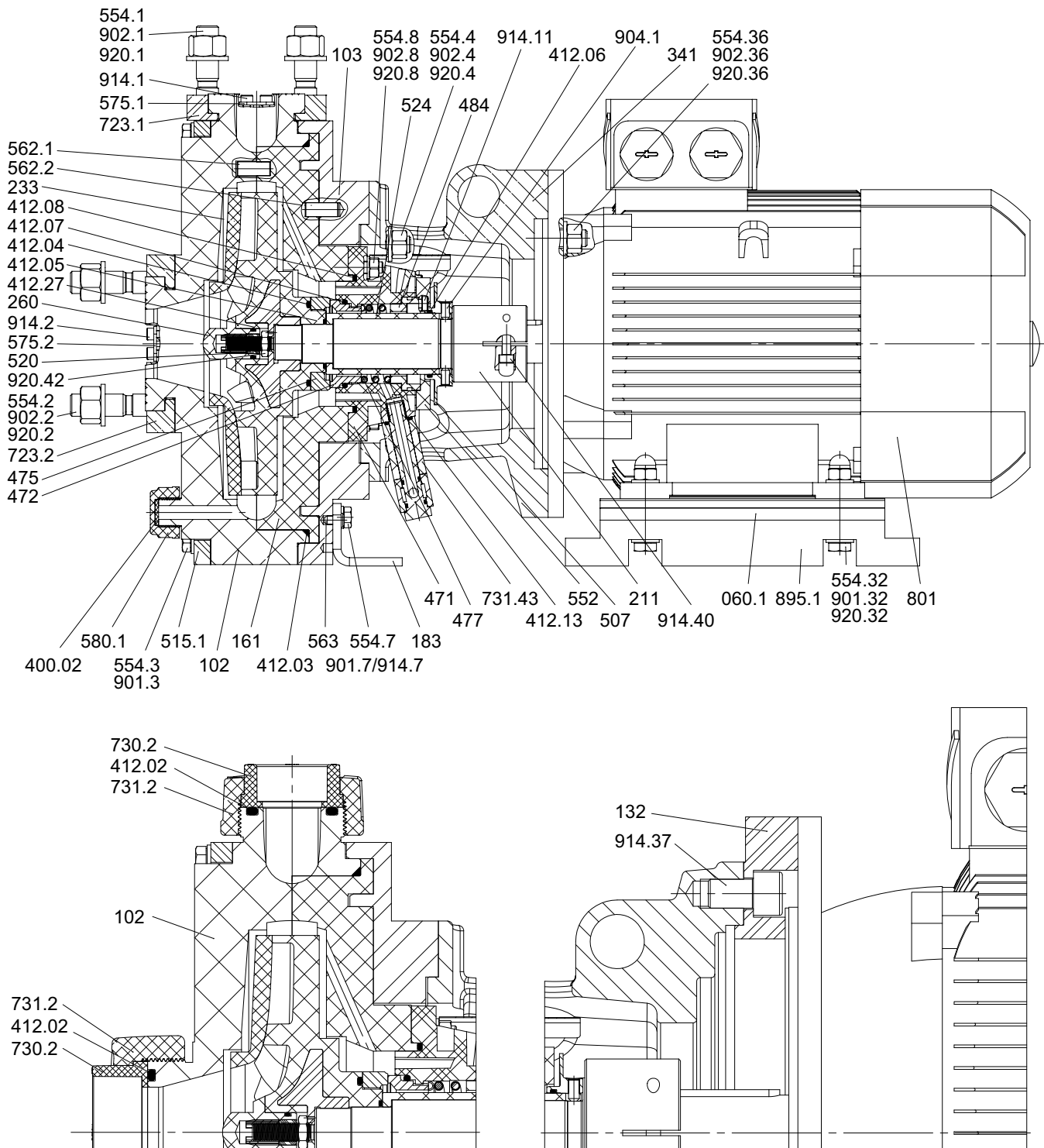



Fig. 15 Sectional drawing

## 9.2 Technical specifications

 Further technical data (→ data sheet).

### 9.2.1 Ambient conditions

 Operation under any other ambient conditions should be agreed with the manufacturer.

Material Volute casing	Tempera- ture [°C]	Relative humidity [%]		Instal- lation height above sea level [m]
		Long- term	Short- term	
PP	+5 to +50	≤ 85	≤ 100	≤ 1000
PP (con- ductive)	+5 to +50	≤ 85	≤ 100	≤ 1000
PVDF	-10 to +50	≤ 85	≤ 100	≤ 1000
PVDF (conduc- tive)	-10 to +50	≤ 85	≤ 100	≤ 1000

Tab. 9 Ambient conditions

### 9.2.2 Sound pressure level

Sound pressure (LpA) / sound power level (LwA) of the motor in db(A) at the specified speed in rpm

P [kW]	Size	3550 <sup>1</sup>		2900 <sup>1</sup>		Size	1750 <sup>2</sup>		1450 <sup>2</sup>	
		LpA	LwA	LpA	LwA		LpA	LwA	LpA	LwA
1.1	–	–	–	–	–	90S	58	70	56	68
1.5	90S	69	81	65	77	90L	58	70	56	68
2.2	90L	69	81	65	77	100L	62	74	60	72
3	100L	71	83	67	79	100L	62	74	60	72
4	112M	73	85	69	81	112M	62	74	58	70
5.5	132S	72	84	68	80	132S	68	80	64	76
7.5	132S	72	84	68	80	132M	68	80	64	76
11	160M	77	89	70	82	160M	69	81	65	77
15	160M	77	89	70	82	160L	69	81	65	77
18.5	160L	77	89	70	82	180M	68	73	66	70
22	180M	78	85	67	80	180L	70	73	68	70
30	180L*	78	86	67	80	–	–	–	–	–

Tab. 10 Sound pressure (LpA) / sound power level (LwA) of the motor in db(A)

\*) Motor with increased power

Sound pressure (LpA) / sound power level (LwA) of the pump without motor in db(A) at the specified speed in rpm

LTG	Type	3550 <sup>1</sup>		2900 <sup>1</sup>		1750 <sup>2</sup>		1450 <sup>2</sup>	
		LpA	LwA	LpA	LwA	LpA	LwA	LpA	LwA
1	32-125	65	76	62	73	52	63	50	61
1	32-160	66	77	63	74	53	64	51	62
1	32-200	69	80	66	77	55	66	53	64
1	50-125	69	80	66	77	55	66	53	64
1	50-160	70	81	67	78	56	67	54	65
2	50-200	72	82	69	79	57	68	55	66
2	65-160	73	83	70	80	58	69	56	67
2	80-160	75	85	72	82	59	70	57	68
2	80-200	77	87	74	84	61	72	59	70
2	100-200	79	89	76	86	63	74	61	72

Tab. 11 Sound pressure (LpA) / sound power level (LwA) of the pump without motor in db(A)

LTG) Bearing carrier size

- 1) 2-pole motor
- 2) 4-pole motor

Room and foundation influences are not taken into account.  
The tolerance for these values is  $\pm 3$  dB(A). Measured values apply to best-point operation.

Depending on the noise emissions, the following measures must be taken at places where personnel may be present:

- < 70 db(A) no measures
- > 70 db(A) Personnel continuously exposed to this level of noise must be provided with suitable noise protection.
- < 85 db(A) No special measures are required for personnel who are occasionally exposed to this level of noise for short periods.
- > 85 db(A) This area must be considered a hazard zone. Attach clearly visible warning signs to all points of access. All personnel even if in the area for only a short period, must be compelled to wear ear protection.
- > 105 db(A) Special noise protection appropriate to the noise level and frequency spectrum must be installed. Attach clearly visible warning signs to all points of access. All personnel even if in the area for only a short period, must be compelled to wear a complete acoustic helmet. It must be ensured that the noise emitted via windows, doors and walls does not constitute a hazard to the environment.

### Calculation of the total sound pressure level / sound power level

Use the following data for the calculation:

- Sound pressure level / sound power level of the motor being used (LA) (→ [Tab. 10 Sound pressure \(LpA\) / sound power level \(LwA\) of the motor in db\(A\), Page 36](#)).
- Sound pressure level / sound power level of the pump at the operating speed (LB) (→ [Tab. 11 Sound pressure \(LpA\) / sound power level \(LwA\) of the pump without motor in db\(A\), Page 36](#)).

Formula for calculation:

$$\text{Total level} = 10 \lg (10^{LA/10} + 10^{LB/10}) \text{ dB}$$

Example calculation:

LA = 65 dB and LB = 75 dB

$$\text{Total level} = 10 \lg (10^{65/10} + 10^{75/10}) \text{ dB}$$

$$\text{Total level} = 10 \lg (10^{6.5} + 10^{7.5}) \text{ dB}$$

$$\text{Total level} = 75.4 \text{ dB}$$

### 9.2.3 Flange tightening torques

		Tightening torque <sup>1)</sup> MD [Nm] for the versions		
d [mm]	DN [mm]	Flat sealing ring up to max. 10 bar	Profile seal up to max. 16 bar	O-ring max. 16 bar
32	25	15	12	12
40	32	20	15	15
50	40	25	15	15
63	50	30	20	20
75	65	35	20	20
90	80	35	20	20
110	100	35	20	20
125	100	35	20	20

Tab. 12 Flange tightening torques

1) Use a torque wrench

### 9.2.4 Tightening torques of casing screws

 Apply graphite paste to metallic connections prior to assembly.

Size	Metal on		Pump shaft / flange motor <sup>3)</sup> (12.9) [Nm]	Metal / plastic <sup>4)</sup> [Nm]	Metal in metal inserts / plastic <sup>5)</sup> [Nm]
	Steel/cast iron <sup>1)</sup> [Nm]	aluminium <sup>2)</sup> [Nm]			
M5	5	4	–	4	4
M6	7.2	6	17	6	5
M8	17.6	10	42	10	–
M10	35	20	–	17	–
M12	60	30	–	22	–
M16	90	40	–	–	–

Tab. 13 Tightening torques of casing screws

- 1) Screws of metal, screwed into nuts of metal or into metal housing parts of steel/cast iron
- 2) Screws made of metal, screwed into metal housing parts (aluminium)
- 3) Cylinder screws item 914.40 are only permitted with strength class 12.9.
- 4) Screws and nuts made of metal that tighten the plastic housing.
- 5) Screws made of metal, screwed into metal inserts in housing parts made of plastic. Inserts screwed-in or insert-molded.

### 9.2.5 Flushing quantity for quenching / continuous quenching

Quenching volume approx. 30 l/h. Value applies to the following conditions:

- Connection: G 1/4"
- Internal diameter of the hose: 12 mm
- Speed range:
  - 900-3000 rpm at 50 Hz
  - 1100-3600 rpm at 60 Hz
- Admission pressure when using a flow rate restrictor: 0.8 - 8 bar

### 9.2.6 Operational limits

#### Volumetric flow of the pumped medium - minimum pumped flow

If operating point differs, consult the manufacturer.

Q <sub>min</sub>	Short-time operation: 0.1 x Q <sub>opt</sub> (approx. 5 min.) Continuous operation: 0.15 x Q <sub>opt</sub>
Q <sub>max</sub>	See pump capacity curve (→ data sheet)
Q <sub>opt</sub>	Volumetric flow in pump capacity curve efficiency optimum

Tab. 14 Volumetric flow of the pumped medium

#### Run the pump for a maximum of 1 minute against the closed fittings

Discuss the performance with the manufacturer whilst the pump is running for periods > 1 minute against the closed fittings.

#### Amounts of gas in the pumped medium

Amounts of gas in the pumped medium reduce the pumping rate and reduce the differential head. Discuss the performance with the manufacturer.

#### Maximum dimension of solids in the pumped medium

The dimensions of occasional solids in the pumped medium must be less than half the height of the vane and smaller than half the nominal bore of the discharge flange.

#### Maximum supply pressure for single-acting STÜBBE mechanical seal UV4

3.0 bar (g)

#### Maximum permissible medium viscosity

100 mm/s<sup>2</sup>

## Operating temperature and operating excess pressure of the pumped medium

Material	Temperature [°C]	maximum permissible operating pressure [bar(g)]
PP-H/PP-H conductive	0	9
	10	9
	20	9
	30	9
	40	9
	50	9
	60	9
	70	7.5
	80	6
PVDF / PVDF conductive	0	9
	10	9
	20	9
	30	9
	40	9
	50	9
	60	9
	70	9
	80	8
	90	7
	100	6

Tab. 15 Operating temperature and operating excess pressure of the pumped medium

## 9.2.7 Switching frequency

Motor power rating [kW]	Switch on / switch off actions per hour
0.18 – 7.5	15
11 – 30	12
30 – 37	8

Tab. 16 Switching frequency

## 9.3 Special tool

Tool	Use
Wrench	Dismantling the impeller cap
Wrench socket	Loosening the impeller nut (920.31)

Tab. 17 Special tool

## 9.4 Declaration of conformity in accordance with EC machinery directive

<b>EU Declaration of Conformity</b>	
	
Stübbe GmbH & Co. KG, Hollwieser Straße 5, 32602 Vlotho, Germany, declares on its own authority that the following products	
Description	
Centrifugal pumps with mechanical seal <b>BE, BX, NM, NMB, NX, SHB</b>	
Magnetically-coupled pumps <b>SHM</b>	
Sump pumps <b>ET, ETL, ETLB, ETLB-E, ETLB-S, ETLB-T, ETLB-ST, ETLB-W</b>	
to which this declaration relates, are in conformity with the following standards:	
	Machinery Directive 2006/42/EC EMC Directive 2014/30/EU ROHS Directive 2011/65/EU With regard to electrical hazards the protective aims of Low Voltage Directive 2014/35/EU have been complied with according to Appendix I no. 1.5.1 of the Machinery Directive 2006/42/EU.
Place and date	Name and signature of authorized person
<hr/> <b>Vlotho, 22.02.2021</b>	<hr/> pp Achim Kaesberg, Corporate Data