

Magnetically driven spiral cased centrifugal pump

Original operating manual

Series SHM



Version BA-2018.08.21 EN
Print-No. 300 092
TR MA DE Rev004

STÜBBE GmbH & Co. KG
Hollwieser Straße 5
32602 Vlotho
Germany
Phone: +49 (0) 5733-799-0
Fax: +49 (0) 5733-799-5000
E-mail: contact@stuebbe.com
Internet: www.stuebbe.com

Subject to technical modifications.

Read carefully before use.
Save for future use.



Table of contents

1	About this document	4	5.4.3	Installing the pressure pipe	17
1.1	Target groups	4	5.4.4	Inspection for stress-free pipe connections	17
1.2	Other applicable documents	4	5.5	Electrical connection	17
1.3	Warnings and symbols	5	5.5.1	Connecting the motor	17
2	General safety instructions	6	5.5.2	Check direction of rotation	17
2.1	Intended use	6	5.6	Performing the hydrostatic test	17
2.2	General safety instructions	6	6	Operation	18
2.2.1	Product safety	6	6.1	Preparing for commissioning	18
2.2.2	Obligations of the operating company	7	6.1.1	Check downtimes	18
2.2.3	Obligations of personnel	7	6.1.2	Filling and bleeding	18
2.3	Specific hazards	8	6.1.3	Check direction of rotation	18
2.3.1	Hazardous pumped liquids	8	6.2	Commissioning	18
2.3.2	Potentially explosive atmospheres	8	6.2.1	Switching on	18
2.3.3	Magnetic field	8	6.2.2	Switching off	19
3	Layout and Function	9	6.3	Shutting down the pump	19
3.1	Marking	9	6.4	Restoring the pump to service	20
3.1.1	Name plate	9	6.5	Operating the stand-by pump	20
3.1.2	ATEX type plate	9	7	Maintenance	21
3.2	Description	10	7.1	Inspections	21
3.3	Assembly	11	7.2	Servicing	21
3.4	Shaft seals	11	7.2.1	Maintenance in accordance with maintenance schedule	22
3.4.1	Magnetic coupling	11	7.2.2	Cleaning the pump	22
4	Transport, Storage and Disposal	12	7.2.3	Check wear limits	22
4.1	Transport	12	7.3	Dismounting	22
4.1.1	Unpacking and inspection on delivery	12	7.3.1	Preparations for dismounting	23
4.1.2	Lifting	13	7.3.2	Dismantling SHM 20-15	23
4.2	Storage	13	7.3.3	Dismantling SHM 40-40 to 65-50	24
4.3	Disposal	13	7.3.4	Dismantling of coupling housing	24
5	Installation and connection	14	7.4	Replacement parts and return	24
5.1	Preparing for installation	14	7.5	Installing	25
5.1.1	Check operating conditions	14	8	Troubleshooting	26
5.1.2	Preparing the installation site	14	9	Appendix	29
5.1.3	Prepare foundation and surface	14	9.1	Replacement parts	29
5.2	Installing with foundation	15	9.1.1	Part numbers and designations	29
5.2.1	Place pump unit on the foundation	15	9.1.2	Drawing SHM 20-15	30
5.2.2	Attaching pump unit	15	9.1.3	Drawing SHM 40-40 to 65-50	31
5.3	Planning pipelines	15	9.2	Technical specifications	32
5.3.1	Specifying supports and flange connections	15	9.2.1	Ambient conditions	32
5.3.2	Specifying nominal widths	15	9.2.2	Wear limits	32
5.3.3	Designing pipelines	15	9.2.3	Flange tightening torques	32
5.3.4	Specifying pipe lengths	16	9.2.4	Tightening torques of casing screws	32
5.3.5	Provide self-priming container	16	9.2.5	Volumetric flow of liquid medium - minimum flow rate	32
5.3.6	Optimizing changes of cross section and direction	16	9.2.6	Sound pressure level	33
5.3.7	Providing safety and control devices (recommended)	16	9.2.7	Switching frequency	33
5.4	Connecting the pipes	17	9.2.8	Minimum flow rate	33
5.4.1	Keeping the piping clean	17	9.3	Maintenance schedule	34
5.4.2	Installing suction pipe	17	9.4	Declaration of conformity in accordance with EC machinery directive	35

List of figures

Fig. 1	Name plate (example)	9
Fig. 2	ATEX type plate (example)	9
Fig. 3	Assembly	11
Fig. 4	Schematic: Attaching lifting gear to the pump unit	13
Fig. 5	Installation with foundation	15
Fig. 6	Straight pipe lengths in front and after the pumps (recommended)	16
Fig. 7	Replacement parts SHM 20-15	30
Fig. 8	Replacement parts SHM 40-40 to 65-50	31
Fig. 9	Wear limits	32

List of tables

Tab. 1	Other application documents, purpose and where found	4
Tab. 2	Warnings and symbols	5
Tab. 3	Measures to be taken if the pump is shut down	19
Tab. 4	Measures depending on the behavior of the pumped liquid	19
Tab. 5	Fault/number assignment	26
Tab. 6	Troubleshooting list	28
Tab. 7	Designation of components according to part numbers	29
Tab. 8	Ambient conditions	32
Tab. 9	Wear limits	32
Tab. 10	Flange tightening torques	32
Tab. 11	Tightening torques of casing screws	32
Tab. 12	Volumetric flow of liquid medium	32
Tab. 13	Maximum sound pressure level, sizes SHM20-15, SHM40-40S and SHM40-40L	33
Tab. 14	Maximum sound pressure level, sizes SHM50-40S, SHM50-40L and SHM65-50	33
Tab. 15	Switching frequency	33
Tab. 16	Minimum flow rate	33
Tab. 17	Maintenance schedule	34

1 About this document

This manual

- is part of the equipment
- applies to all series referred to
- describes safe and proper operation during all operating phases

1.1 Target groups



Operating company

- Responsibilities:
 - Always keep this manual accessible where the device is used on the system.
 - Ensure that employees read and observe this document, particularly the safety instructions and warnings, and the documents which also apply.
 - Observe any additional country-specific rules and regulations that relate to the system.

Qualified personnel, fitter







- Mechanics qualification:
 - Qualified employees with additional training for fitting the respective pipework
- Electrical qualification:
 - Qualified electrician
- Transport qualification:
 - Qualified transport specialist
- Responsibility:
 - Read, observe and follow this manual and the other applicable documents, especially all safety instructions and warnings.

1.2 Other applicable documents

Document/purpose/	Where found
ATEX additional manual (300 365) <ul style="list-style-type: none"> • Additional instructions for use in explosive atmospheres • www.stuebbe.com/pdf_manuels/300365.pdf 	
CE declaration of conformity <ul style="list-style-type: none"> • Conformity with standards 	(→ 9.4 Declaration of conformity in accordance with EC machinery directive, Page 35).
Resistance lists <ul style="list-style-type: none"> • Resistance of materials used to chemicals • www.stuebbe.com/pdf_resistance/300051.pdf 	
Spare parts list <ul style="list-style-type: none"> • Ordering spare parts 	Documentation included
Sectional drawing <ul style="list-style-type: none"> • Sectional drawing, part numbers, component designations 	Documentation included
Supplier documentation <ul style="list-style-type: none"> • Technical documentation for parts supplied by subcontractors 	Documentation included
Data sheet (300 140) <ul style="list-style-type: none"> • Technical specifications, operating conditions, dimensions • www.stuebbe.com/pdf_datasheets/300140.pdf 	

Tab. 1 Other application documents, purpose and where found

1.3 Warnings and symbols

Symbol	Meaning
	<ul style="list-style-type: none"> • Immediate acute risk • Death, serious bodily harm
	<ul style="list-style-type: none"> • Potentially acute risk • Death, serious bodily harm
	<ul style="list-style-type: none"> • Potentially hazardous situation • Minor injury
	<ul style="list-style-type: none"> • Potentially hazardous situation • Material damage
	<p>Safety warning sign</p> <ul style="list-style-type: none"> ▶ Take note of all information highlighted by the safety warning sign and follow the instructions to avoid injury or death.
	Instruction
1., 2., ...	Multiple-step instructions
✓	Precondition
→	Cross reference
	Information, notes

Tab. 2 Warnings and symbols

2 General safety instructions

 The manufacturer accepts no liability for damages caused by disregarding any of the documentation.

2.1 Intended use

- Only use the pump with suitable media (→ resistance lists).
- Do not use pump with solid particles.
- Do not use pump for combustible or explosive fluids.
- Adhere to the operating limits and size-dependent minimum flow rates.
- Avoid dry running:
Initial damage, such as destruction of bearings, seals and plastic parts, will occur within a few seconds.
 - Make sure the pump is only operated with, and never without, pumped liquid.
 - Ensure that the sealing chamber is sufficiently filled.
 - Ensure that there are no excessively high amounts of gas in the pumping medium.
 - Ensure that the pump is operated only within the permissible operating range.
 - Ensure that the insertion of valves or filters does not make the pressure too low on the inlet side of the pump.
 - Ensure that high temperatures and/or low suction pressures of the pumped medium do not cause the vapor pressure to fall below the minimum value, and that gas bubbles are formed at the pairs of bearings.
- Avoid cavitation:
 - Open the suction-side fitting and do not use it to regulate the flow.
 - Do not open the pressure-side fitting beyond the agreed operating point.
- Avoid overheating:
 - Do not operate the pump while the pressure-side fitting is closed.
 - Note minimum flow (→ Data sheet).
- Avoid damage to the motor:
 - Do not open the pressure-side fitting beyond the agreed operating point.
 - Note the maximum permissible number of times the motor can be switched on per hour (→ manufacturer's specifications).
- Consult with the manufacturer regarding any other use of the device.
- If pumps are delivered without motors, then final assembly as a pump assembly must take place in accordance with the provisions of the Machinery Directive 2006/42/EC.
- Use the pump only as part of a large system/tool.

Prevention of obvious misuse (examples)

- Observe pump limits of use regarding temperature, pressure, flow and speed (→ data sheet).
- The power consumption of the pump increases as the specific gravity of the pumped fluid increases. Adhere to the permissible specific gravity in order to eliminate the possibility that the pump, coupling and motor become overloaded (→ data sheet).
A lower specific gravity is permissible. Adapt the auxiliary systems accordingly.
- Do not use the pumps to pump media containing solid particles.
- When using auxiliary plant systems:
 - Ensure compatibility of the operating medium with the product medium.
 - Ensure constant supply of the relevant operating medium.
- Pumps used with water as the pumped liquid must not be used for foodstuffs or drinking water. Use for food or drinking water only if specified in the data sheet.
- The type of installation should be selected only in accordance with these operating instructions. For example, the following are not allowed:
 - Hanging base plate pumps in the pipe
 - Overhead installation
 - Installation in the immediate vicinity of extreme heat or cold sources
 - Installation too close to a wall

2.2 General safety instructions

 Observe the following regulations before carrying out any work.

2.2.1 Product safety

The pump has been built according to state-of-the-art technology and the recognized technical safety regulations. Nevertheless, operation of the pump can still put the life and health of the user or third parties at risk or damage the pump or other property.

- Operate the pump only if it is in perfect technical condition and use it only as intended, staying aware of safety and risks, and in adherence to the instructions in this manual.
- Keep this manual and all other applicable documents complete, legible and accessible to personnel at all times.
- Refrain from any procedures and actions that would pose a risk to personnel or third parties.
- In the event of any safety-relevant faults, shut down the pump immediately and have the fault corrected by appropriate personnel.
- In addition to the entire documentation for the product, comply with statutory or other safety and accident-prevention regulations and the applicable standards and guidelines in the country where the pump is operated.

2.2.2 Obligations of the operating company

Safety-conscious working

- Operate the pump only if it is in perfect technical condition and use it only as intended, staying aware of safety and risks, and in adherence to the instructions in this manual.
- Ensure that the following safety aspects are observed and monitored:
 - Intended use
 - Statutory or other safety and accident-prevention regulations
 - Safety regulations governing the handling of hazardous substances
 - Applicable standards and guidelines in the country where the pump is operated
 - Applicable guidelines of the operator
- Make personal protective equipment available.

Qualified personnel

- Make sure all personnel tasked with work on the pump have read and understood this manual and all other applicable documents, especially the safety, maintenance and repair information, before they start any work.
- Organize responsibilities, areas of competence and the supervision of personnel.
- Ensure that all work is carried out by specialist technicians only:
 - Installation, repair and maintenance work
 - Transportation
 - Work on the electrical system
- Make sure that trainee personnel only work on the pump under supervision of specialist technicians.

Safety equipment

- Provide the following safety equipment and verify its functionality:
 - For hot, cold and moving parts: pump safety guarding provided by the customer
 - For pumps without capability to run dry: Dry run protection
 - For potential electrostatic charging: provide suitable grounding

Warranty

- Obtain the manufacturer's approval prior to carrying out any modifications, repairs or alterations during the warranty period.
- Only use genuine parts or parts that have been approved by the manufacturer.

2.2.3 Obligations of personnel

- All directions given on the pump must be followed (and kept legible), e.g. the arrow indicating the sense of rotation and the markings for fluid connections.
- Pump, coupling guard and components:
 - Do not step on them or use as a climbing aid
 - Do not use them to support boards, ramps or beams
 - Do not use them as a fixing point for winches or supports
 - Do not use them for storing paper or similar materials
 - Do not use the hot pump or motor components as a heating point
 - Do not de-ice the pump using gas burners or similar tools
- Do not remove the safety guarding for hot, cold or moving parts during operation.
- Use personal protective equipment if necessary.
- Only carry out work on the pump while it is not running.
- Before all installation and maintenance work, disconnect the motor from the mains and secure it against being switched back on again.
- Never reach into the suction or discharge flange.
- Following all work on the pump, refit safety devices in accordance with the instructions and bring into service.
- Do not make any modifications to the device.

2.3 Specific hazards

2.3.1 Hazardous pumped liquids

- When handling hazardous fluids, observe the safety regulations for the handling of hazardous substances.
- Use personal protective equipment when carrying out any work on the pump.
- Collect leaking pumped liquid and residues in a safe manner and damage them in accordance with environmental regulations.

2.3.2 Potentially explosive atmospheres

Observe ATEX additional manual

- Additional instructions for use in explosive atmospheres
- www.stuebbe.com/pdf_manuals/300365.pdf



2.3.3 Magnetic field

The magnetic field of the magnetic coupling can destroy products that are sensitive to magnets. These include

- Pacemakers
- ID cards with magnetic strips
- Credit cards and check cards
- Electrical, electronic precision devices (e.g. mechanical and digital clocks, calculators, hard disk drives)

Individuals with implanted pacemakers must:

- Be kept away from the pump with magnetic coupling and parts of the magnetic coupling
- Not be allowed to complete work with, or on, the magnetic parts

3 Layout and Function

3.1 Marking

3.1.1 Name plate

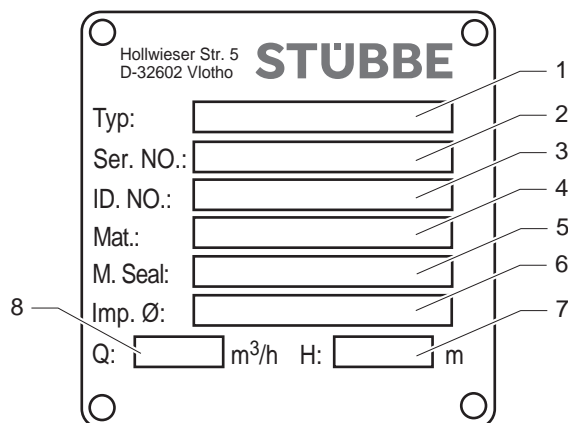

Fig. 1 Name plate (example)

- 1 Pump type
- 2 Serial number
- 3 Ident. number
- 4 Housing / sealing material
- 5 Shaft seal information
- 6 Impeller diameter [mm]
- 7 Differential head
- 8 Flow

3.1.2 ATEX type plate

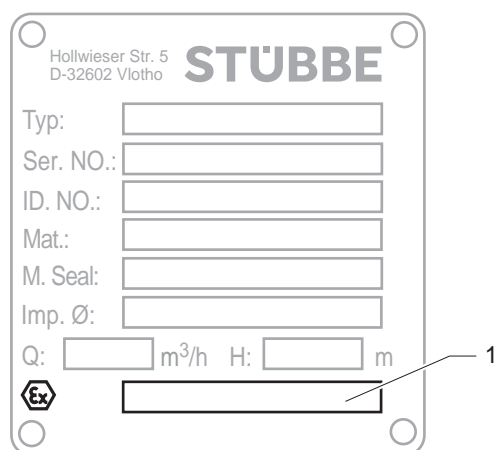

Fig. 2 ATEX type plate (example)

- 1 Explosion protection label

3.2 Description

Non self-priming, horizontal centrifugal pump.
Magnetically coupled and hermetically sealed.

3.3 Assembly

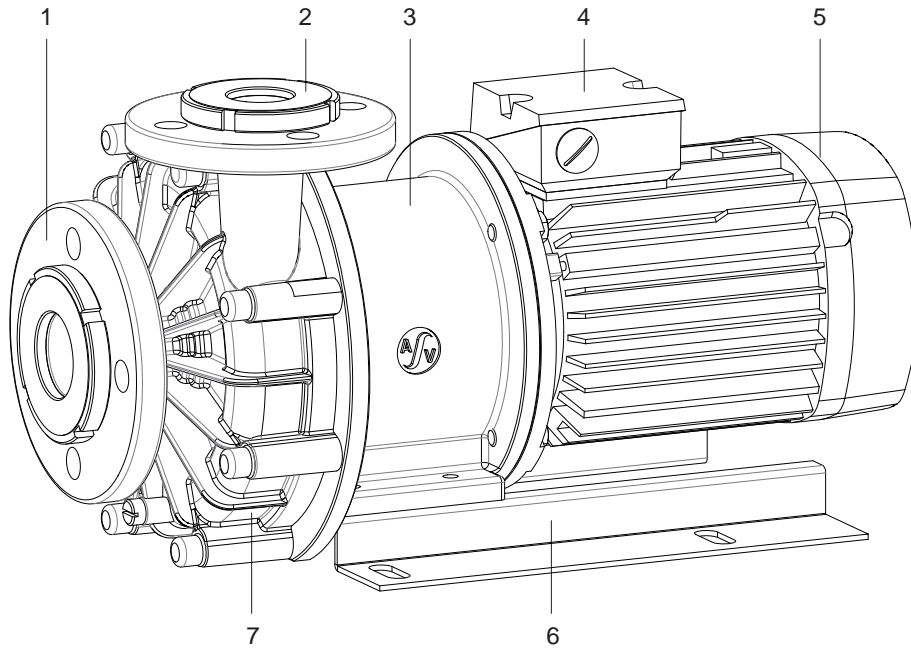



Fig. 3 Assembly

- | | | |
|---------------------|----------------|-----------------|
| 1 Suction flange | 4 Terminal box | 7 Volute casing |
| 2 Pressure flange | 5 Motor | |
| 3 Magnetic coupling | 6 Base frame | |

3.4 Shaft seals

 Only one of the following shaft seals is used.

3.4.1 Magnetic coupling

 Magnetic coupling is hermetically sealed, no leakages.

4 Transport, Storage and Disposal

4.1 Transport

 The user/owner is responsible for the transport of the pump.

 Weight specifications (→ documents for the particular order)

4.1.1 Unpacking and inspection on delivery

1. Unpack the pump/pump assembly upon delivery and inspect it for transport damage.
2. Check completeness and accuracy of delivery.
3. Ensure that the information on the name plate agrees with the order/design data.
4. Report any transportation damage to the manufacturer immediately.
5. Dispose of packaging material according to local regulations.

4.1.2 Lifting

⚠ DANGER

Death or limbs crushed as a result transported items falling over!

- ▶ Use lifting gear appropriate for the total weight to be transported.
- ▶ Attach lifting gear in accordance with the following diagrams.
- ▶ Never use the lifting eye of the motor as the attachment point for lifting the entire pump (the lifting eye of the motor may be used for securing a pump assembly with a high center of gravity against being knocked over).
- ▶ Do not stand under suspended loads.

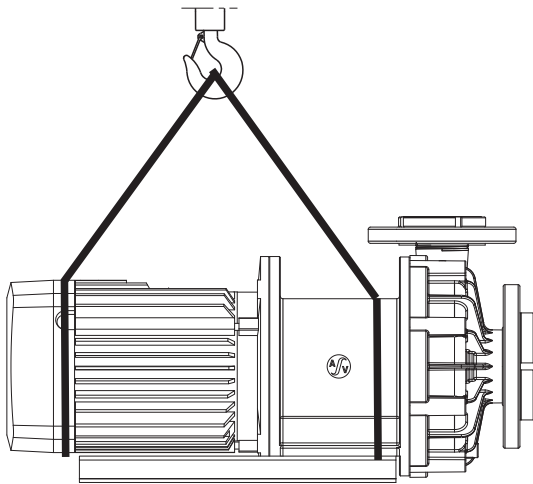

Fig. 4 Schematic: Attaching lifting gear to the pump unit

1. Attach lifting gear in accordance with the following diagrams.
2. Lift the pump/pump assembly appropriately.

4.2 Storage

NOTE

Material damage due to inappropriate storage!

- ▶ Store the pump properly.
1. Seal all openings with blind flanges, blind plugs or plastic covers.
 2. Make sure the storage room meets the following conditions:
 - Dry
 - Frost-free
 - Vibration-free
 - UV protected
 3. Rotate the pump shaft twice a month.
 4. Make sure the shaft and bearing change their rotational position in the process.

4.3 Disposal

i Plastic parts can be contaminated by poisonous or radioactive pumped liquids to such an extent that cleaning will be insufficient.

⚠ WARNING

Risk of poisoning and environmental damage by the pumped liquid or oil!

- ▶ Use personal protective equipment when carrying out any work on the pump.
 - ▶ Prior to the disposal of the pump:
 - Collect and damage any escaping pumped liquid or oil in accordance with local regulations.
 - Neutralize residues of pumped liquid in the pump.
 - ▶ Remove plastic parts and damage them in accordance with local regulations.
-
- ▶ Dispose of the pump in accordance with local regulations.

5 Installation and connection

 For pumps in potentially explosive atmospheres (→ ATEX additional manual).

NOTE

Material damage due to distortion or passage of electrical current in the bearing!

- ▶ Do not make any structural modifications to the pump assembly or pump casing.
- ▶ Do not carry out any welding work on the pump assembly or pump casing.

NOTE

Material damage caused by dirt!

- ▶ Do not remove the transport seals until immediately before installing the pump.
- ▶ Do not remove any covers or transport and sealing covers until immediately before connecting the pipes to the pump.

5.1 Preparing for installation

5.1.1 Check operating conditions

- ▶ Ensure the required operating conditions are met:
 - Resistance of body and seal material to the medium (→ resistance lists).
 - Required ambient conditions (→ [9.2.1 Ambient conditions, Page 32](#)).

5.1.2 Preparing the installation site

- ▶ Ensure the installation site meets the following conditions:
 - Pump is freely accessible from all sides
 - Sufficient space for the installation/removal of the pipes and for maintenance and repair work, especially for the removal and installation of the pump and the motor
 - Pump not exposed to external vibration (damage to bearings)
 - No corrosive exposure
 - Frost protection

5.1.3 Prepare foundation and surface

✓ Aids, tools, materials:

- Steel shims
- Spirit level

 Installation options:

- With concrete foundation
- With steel foundation frames
- Without foundation

1. Ensure the foundation and surface meet the following conditions:

- Level and horizontal
- Clean (no oil, dust or other impurities)
- Capable of bearing the weight of the pump assembly and all operating forces
- Stability of the pump ensured
- With concrete foundation: Normal concrete of strength class X0 in accordance with DIN EN 206

2. Clean pump sump carefully.

5.2 Installing with foundation

NOTE

Material damage due to distortion of base plate.

- ▶ Position the base plate as follows on the foundation and attach.

5.2.1 Place pump unit on the foundation

- ✓ Aids, tools, materials:
 - Anchor bolts (→ installation drawing)
 - Steel shims
 - Mortar casting compound, no shrinkage
 - Spirit level
 - 1. Lifting the pump unit (→ 4.1 Transport, Page 12).
 - 2. Hook anchor bolts in the mounting holes on the base plate from below.
-  Observe manufacturers information when using the fixing material.
- 3. Position the pump unit on the foundation. When doing so lower the anchor bolts into the prepared anchoring holes.

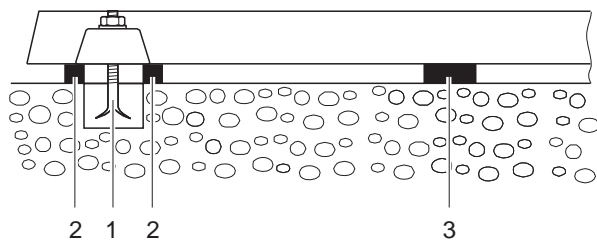



Fig. 5 Installation with foundation

- 4. Align the pump for height and system dimensions using steel shims as follows:
 - Arrange steel shims (2) to the left and right of each anchor bolt (1).
 - If the distance between the anchoring holes is > 750 mm, then arrange additional steel shims (3) on each side of the base plate in the center.
- 5. Ensure that the base plate lies flat against steel shims.
- 6. Check the permissible height deviation (1mm/m) using a mechanical spirit level in a longitudinal and a transverse direction
- 7. Repeat the procedure until the base plate is correctly aligned.

5.2.2 Attaching pump unit

-  Filling the base plate with mortar casting compound improves dampening properties.

- 1. Fill the anchoring holes with mortar casting compound.
- 2. When the mortar casting compound has set, bolt the base plate at three points to the specified tightening torque.
- 3. Before tightening the remaining bolts, arrange shims next to every bolt to even out any irregularities in the mounting surface.

5.3 Planning pipelines

-  Water hammer may damage the pump or the system. Plan the pipes and fittings as far as possible to prevent water hammer occurring.

5.3.1 Specifying supports and flange connections

NOTE

Material damage due to excessive forces and torques on the pump.

- ▶ Ensure pipe connection without stress.

1. Plan pipes safely:
 - No pulling or thrusting forces
 - No bending moments
 - Adjust for changes in length due to temperature changes (compensators, expansion shanks)
2. Support pipes in front of the pump.
3. Ensure the pipe supports have permanent low-friction properties and do not seize up due to corrosion.

5.3.2 Specifying nominal widths

-  Keep the flow resistance in the pipes as low as possible.

1. Ensure nominal suction pipe width is not smaller than the nominal suction flange width.
 - Recommended flow velocity < 1 m/s
 - Maximum flow velocity = 9 m/s
2. Ensure the nominal pressure line width is not smaller than the nominal discharge flange width.
 - Recommended flow velocity < 3 m/s
 - Maximum flow velocity = 12 m/s

5.3.3 Designing pipelines

- ▶ Plan pipes safely:
 - No pulling or thrusting forces
 - No bending moments
 - Adjust for changes in length due to temperature changes (compensators, expansion shanks)

5.3.4 Specifying pipe lengths

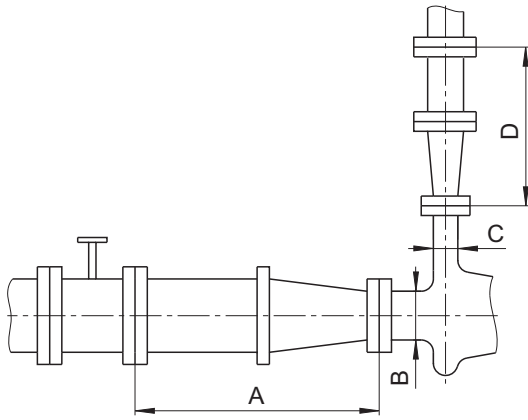

Fig. 6 Straight pipe lengths in front and after the pumps (recommended)

A > 5x DN_s

B DN_d

C DN_d

D > 5x DN_d

- ▶ Observe recommended minimum values when installing the pump.

 Suction side: Shorter lengths are possible, but may limit hydraulic performance data.

Pressure side: Shorter lengths are possible, but may result in increased noise development.

5.3.5 Provide self-priming container

 A self-priming container can be used to make the pump self-priming.

1. Select container volumes according to the size of the pump.
2. Clean containers carefully prior to commissioning or initial filling.

5.3.6 Optimizing changes of cross section and direction

1. Avoid radii of curvature of less than 1.5 times the nominal pipe diameter.
2. Avoid abrupt changes of cross-section along the piping.

5.3.7 Providing safety and control devices (recommended)

Avoid contamination

1. Install filters in the suction pipe.
2. Install a differential pressure gauge with contact manometer to monitor contamination.

Avoid reverse running

1. Install a non-return valve between the discharge flange and stop valve, to ensure that the medium does not flow back after the pump is switched off.
2. In order to enable venting, include vent connection between discharge flanges and non-return valve.

Make provisions for isolating and shutting off the pipes

 For maintenance and repair work.

- ▶ Provide shut-off devices in the suction pipe and pressure line.

Allow measurements of the operating conditions

1. Provide pressure gauge in the suction pipe and pressure line for pressure measurement.
2. Provide motorside load monitors (over and underload).
3. Provide pressure measurement on the pump side.

Provide dry run protection

- ▶ In order to protect the pump from dry running and resulting damage
 - Provide dry run protection
 - e.g. PTM pressure and temperature monitoring sensor

5.4 Connecting the pipes

NOTE

Material damage due to excessive forces and torques on the pump.

- ▶ Ensure pipe connection without stress.

5.4.1 Keeping the piping clean

NOTE

Material damage due to impurities in the pump!

- ▶ Make sure no impurities can enter the pump.

1. Clean all piping parts and fittings prior to assembly.
2. Flush all pipes carefully with neutral medium.
3. Ensure no flange seals protrude inwards.
4. Remove any blind flanges, plugs, protective foils and/or protective paint from the flanges.

5.4.2 Installing suction pipe

1. Remove the transport and sealing covers from the pump.
2. Fit suction pipe stress-free and sealed. ([→ 9.2.3 Flange tightening torques, Page 32](#)).
3. Ensure no seals protrude inwards.
4. For the suction process: Install foot valve in the suction pipe in order to prevent the pump and suction pipe from dry running when pump is not running.

5.4.3 Installing the pressure pipe

1. Remove the transport and sealing covers from the pump.
2. Fit the pressure line stress-free and sealed ([→ 9.2.3 Flange tightening torques, Page 32](#)).
3. Ensure no seals protrude inwards.

5.4.4 Inspection for stress-free pipe connections

- ✓ Piping installed and cooled down
1. Disconnect the pipe connecting flanges from the pump.
 2. Check whether the pipes can be moved freely in all directions within the expected range of expansion:
 - Nominal width < 150 mm: by hand
 - Nominal width > 150 mm: with a small lever
 3. Make sure the flange surfaces are parallel.
 4. Reconnect the pipe connecting flanges to the pump.
 5. If present, check support foot for stress.

5.5 Electrical connection

DANGER

Risk of electrocution!

- ▶ All electrical work must be carried out only by qualified electricians.
- ▶ Before all work on the electrical system, disconnect the motor from the mains and secure against being switched back on again.

5.5.1 Connecting the motor

 Follow the instructions of the motor manufacturer.

1. Connect the motor according to the connection diagram.
2. Make sure no danger arises due to electric power.
3. Install an EMERGENCY STOP switch.

5.5.2 Check direction of rotation

 Only possible when starting up ([→ 6.2 Commissioning, Page 18](#)).

5.6 Performing the hydrostatic test

 Only necessary if the entire system needs to be tested under pressure.

NOTE

Material damage due to bursting of pump casing.

- ▶ Testing pressure must not exceed the permissible pump pressure ([→ documents for the particular order](#)).
- ▶ Make sure the testing pressure does not exceed the permissible pump pressure.
 - If necessary, do not perform pressure test on the pump.

6 Operation

 For pumps in potentially explosive atmospheres (→ ATEX additional manual).

6.1 Preparing for commissioning

6.1.1 Check downtimes

- ▶ Check downtimes (→ [6.4 Restoring the pump to service, Page 20](#)).

6.1.2 Filling and bleeding

WARNING

Risk of injury and poisoning due to hazardous pumped liquids!

- ▶ Use protective equipment for any work on the pump.
- ▶ Safely collect the fluid and dispose of it in accordance with environmental regulations.

NOTE

Material damage as a result of dry running

- ▶ Make sure the pump is filled properly.

1. If present, fill and vent self-priming container with fluid.
2. Open the suction-side fitting.
3. Open the pressure-side fitting.
4. Fill pump and suction pipe with fluid.
5. Verify that no pipe connections are leaking.

6.1.3 Check direction of rotation

DANGER

Danger to life from rotating parts.

- ▶ Use personal protective equipment when carrying out any work on the pump.
- ▶ Maintain an adequate distance from rotating parts.

NOTE

Material damage as a result of dry running

- ▶ Make sure the pump is filled properly.

1. Switch on motor for max. 2 seconds and switch it off again immediately.
2. Check whether the sense of rotation of the motor matches the direction of rotation on the fan impeller.
3. If the sense of rotation is different: change over the two phases (→ [5.5 Electrical connection, Page 17](#)).

6.2 Commissioning

6.2.1 Switching on

- ✓ Pump set up and connected properly
- ✓ Motor set up and connected properly
- ✓ Align motor precisely to the pump
- ✓ All connections stress-free and sealed
- ✓ All safety equipment installed and tested for functionality
- ✓ Pump prepared, filled and vented correctly
- ✓ Auxiliary systems switched on if present.

DANGER

Risk of injury due to running pump!

- ▶ Do not touch the pump when it is running.
- ▶ Ensure that the coupling guard is attached.
- ▶ Do not carry out any work on the pump when it is running.
- ▶ Allow the pump to cool down completely before starting any work.

DANGER

Risk of injury and poisoning due to pumped liquid spraying out!

- ▶ Use personal protective equipment when carrying out any work on the pump.

NOTE

Risk of cavitation if suction flow is restricted!

- ▶ Open the suction-side fitting and do not use it to regulate the flow.
- ▶ Do not open the pressure-side fitting beyond the operating point.

NOTE

Material damage due to overheating.

- ▶ Do not operate the pump for long periods with the pressure-side fitting closed.
- ▶ Observe minimum flow (→ documents for the particular order).

NOTE

Material damage as a result of dry running

- ▶ Make sure the pump is filled properly.

1. Turn on auxiliary systems (if present).
2. Open the suction-side fitting.
3. Close the pressure-side fitting.
4. Switch on the motor and check it for smooth running.
5. Once the motor has reached its nominal speed, open the pressure-side fitting slowly until the operating point is reached.

6. Make sure temperature change is smaller than 5 K/min for pumps with hot fluids.
7. After the initial stress due to the pressure and operating temperature, check that the pump is not leaking.

6.2.2 Switching off

- ✓ Pressure-side fitting closed (recommended)

⚠ WARNING

Risk of injury due to hot pump parts!

- ▶ Use personal protective equipment when carrying out any work on the pump.

1. Switch off motor.
2. Check all connecting bolts and tighten them if necessary (only after initial commissioning).

6.3 Shutting down the pump

⚠ DANGER

Risk of injury due to running pump!

- ▶ Do not touch the pump when it is running.
- ▶ Do not carry out any work on the pump when it is running.
- ▶ Before all installation and maintenance work, disconnect the motor from the mains and secure it against being switched back on again.

⚠ DANGER

Risk of electrocution!

- ▶ All electrical work must be carried out only by qualified electricians.
- ▶ Before all work on the electrical system, disconnect the motor from the mains and secure against being switched back on again.

⚠ WARNING

Risk of injury and poisoning due to hazardous pumped liquids!

- ▶ Use protective equipment for any work on the pump.
- ▶ Collect leaking liquid safely and damage fitting in accordance with local regulations.

- ▶ Take the following measures whenever the pump is shut down:

Pump is	Action
shut down	▶ Take measures appropriate for the fluid (→ Tab. 4 Measures depending on the behavior of the pumped liquid, 19 Page).
...emptied	▶ Close suction and pressure-side fitting.
...dismounted	▶ Isolate the motor from its power supply and secure it against unauthorized switch-on.
...put into storage	▶ Note measures for storage.

Tab. 3 Measures to be taken if the pump is shut down

Behavior of the pumped liquid	Duration of shutdown (depending on process)	
	Short	Long
Crystallized or polymerized, solids sedimenting	▶ Flush the pump.	▶ Flush the pump.
Solidifying/ freezing, non-corrosive	▶ Heat up or empty the pump and containers.	▶ Empty the pump and containers.
Solidifying/ freezing, corrosive	▶ Heat up or empty the pump and containers.	▶ Empty the pump and containers.
Remains liquid, non-corrosive	–	–
Remains liquid, corrosive	–	▶ Empty the pump and containers.

Tab. 4 Measures depending on the behavior of the pumped liquid

6.4 Restoring the pump to service

1. Complete all steps as for commissioning ([→ 6.2 Commissioning, Page 18](#)).
2. If the pump is shut down for over 1 year, replace elastomer seals (O-rings, shaft sealing rings).

6.5 Operating the stand-by pump

✓ Stand-by pump filled and bled

 Operate the stand-by pump at least once a week.

1. Fully open the suction-side fitting.
2. Open pressure-side fitting far enough so that the stand-by pump operating temperature is achieved and heating is even ([→ 6.2.1 Switching on, Page 18](#)).

7 Maintenance

 For pumps in potentially explosive atmospheres (→ ATEX additional manual).

 Trained service technicians are available for fitting and repair work. Submit evidence of conveyed medium on request (DIN safety data sheet or safety certificate).

7.1 Inspections

 The inspection intervals depend on the operational strain on the pump.

DANGER

Risk of injury due to running pump!

- ▶ Do not touch the pump when it is running.
- ▶ Do not carry out any work on the pump when it is running.

WARNING

Risk of injury and poisoning due to hazardous pumped liquids!

- ▶ Use personal protective equipment when carrying out any work on the pump.

1. Check at appropriate intervals:
 - Adherence to the minimum flow rate
 - Normal operating conditions unchanged
 - Alignment of coupling and condition of elastic elements
2. For trouble-free operation, always ensure the following:
 - No dry running
 - No leaks
 - No cavitation
 - Suction side open gate valves
 - Free and clean filters
 - Sufficient pump inlet pressure
 - No unusual running noises or vibrations
 - No parting of magnetic coupling

7.2 Servicing

 Operating life of antifriction bearings when operated within the permissible range: >2 years.

Intermittent operation, high temperatures, low viscosities and aggressive ambient and process conditions reduce the service life of antifriction bearings.

 Plain bearings are subject to natural wear and tear which is heavily dependent on the respective operating conditions. It is therefore not possible to make general statements about the operating life.

DANGER

Danger to life and material damage due to magnetic field.

- ▶ Make sure that personnel with pacemakers do not complete work on the pump.
- ▶ Secure the work place and if necessary cordon off:
 - Make sure that personnel with pacemakers keep a safe distance of > 1 m.
 - Make sure that no magnetizable metal parts can be attracted by the pump's magnetic coupling.
 - Make sure that parts of the magnetic coupling cannot be attracted by the magnetizable metal parts.
- ▶ Maintain a safe distance of at least 150 mm from the magnetic coupling for magnetically sensitive objects.

DANGER

Risk of injury due to running pump!

- ▶ Do not touch the pump when it is running.
- ▶ Do not carry out any work on the pump when it is running.
- ▶ Before all installation and maintenance work, disconnect the motor from the mains and secure it against being switched back on again.

DANGER

Risk of electrocution!

- ▶ All electrical work must be carried out only by qualified electricians.
- ▶ Before all work on the electrical system, disconnect the motor from the mains and secure against being switched back on again.

DANGER

Danger to life from rotating parts.

- ▶ Ensure coupling guard is fitted after work on the pump.

WARNING

Risk of injury and poisoning due to hazardous or hot fluid!

- ▶ Use personal protective equipment when carrying out any work on the pump.
- ▶ Allow the pump to cool completely before commencing any work.
- ▶ Make sure the pump is depressurized.
- ▶ Empty the pump, safely collect the pumped liquid and damage it in accordance with environmental rules and requirements.

7.2.1 Maintenance in accordance with maintenance schedule

- ▶ Perform maintenance work in accordance with the maintenance schedule (→ [9.3 Maintenance schedule, Page 34](#)).

7.2.2 Cleaning the pump

NOTE

High water pressure or spray water can damage bearings!

- ▶ Do not clean bearing areas with a water or steam jet.
- ▶ Clean large-scale grime from the pump.

7.2.3 Check wear limits

NOTE

Material damage due to worn parts.

- ▶ Check wear limits regularly.
- ▶ Replace worn components immediately.
- ▶ Only use genuine replacement parts from the manufacturer.

1. Measuring wear limits (→ [9.2.2 Wear limits, Page 32](#)).
 - Axial bearing
 - Bearing bush
2. Replace worn components.

7.3 Dismounting

DANGER

Danger to life and material damage due to magnetic field.

- ▶ Make sure that personnel with pacemakers do not complete work on the pump.
- ▶ Secure the work place and if necessary cordon off:
 - Make sure that personnel with pacemakers keep a safe distance of > 1 m.
 - Make sure that no magnetizable metal parts can be attracted by the pump's magnetic coupling.
 - Make sure that parts of the magnetic coupling cannot be attracted by the magnetizable metal parts.
- ▶ Maintain a safe distance of at least 150 mm from the magnetic coupling for magnetically sensitive objects.

DANGER

Risk of injury due to running pump!

- ▶ Do not touch the pump when it is running.
- ▶ Do not carry out any work on the pump when it is running.
- ▶ Before all installation and maintenance work, disconnect the motor from the mains and secure it against being switched back on again.

DANGER

Risk of electrocution!

- ▶ All electrical work must be carried out only by qualified electricians.
- ▶ Before all work on the electrical system, disconnect the motor from the mains and secure against being switched back on again.

WARNING

Risk of injury and poisoning due to hazardous or hot fluid!

- ▶ Use personal protective equipment when carrying out any work on the pump.
- ▶ Allow the pump to cool completely before commencing any work.
- ▶ Make sure the pump is depressurized.
- ▶ Empty the pump, safely collect the pumped liquid and damage it in accordance with environmental rules and requirements.

WARNING

Risk of injury due to heavy components!

- ▶ Pay attention to the component weight. Lift and transport heavy components using suitable lifting gear.
- ▶ Set down components safely and secure them against overturning or rolling away.

WARNING

Risk of injury during disassembly!

- ▶ Secure the pressure-side gate valve against accidental opening.
- ▶ Depressurize the blocking pressure system, if available.
- ▶ Wear protective gloves, components can become very sharp-edged due to wear or damage.
- ▶ Remove spring-loaded components carefully (e.g. mechanical seal, stressed bearing, valves etc.), as components can be ejected by the spring stress.
- ▶ Observe the manufacturer's specifications (e.g. for the motor, coupling, mechanical seal, blocking pressure system, cardan shaft, drives, belt drive etc.).

WARNING

Risk of injury during disassembly work on the magnetic coupling!

- ▶ Use jacking screws to disassemble the bearing bracket in order to prevent a sudden moving together of the magnetic coupling due to magnetic forces.

NOTE

Material damage due to incorrect dismantling/installation of the pump.

- ▶ Only specialist mechanics should complete dismantling/installation work.

7.3.1 Preparations for dismantling

- ✓ Pump is depressurized
- ✓ Pump completely empty, flushed and decontaminated
- ✓ Electrical connections disconnected and motor secured against switch-on
- ✓ Pump cooled down
- ✓ Coupling guard removed
- ✓ For a coupling with spacer piece: remove distance piece
- ✓ Pressure gauge lines, pressure gauge and fixtures dismounted

WARNING

Risk of injury during disassembly work on the magnetic coupling!

- ▶ Use jacking screws to disassemble the bearing bracket in order to prevent a springing back of the magnetic coupling due to magnetic forces.

NOTE

Material damage, fragile components.

- ▶ Dismount ceramic parts of the plain bearing and magnets of the magnetic coupling with care, do not hit or knock.

1. Dismantle the pipes on the suction and pressure side.
2. Remove pump from the system.
3. When dismantling, observe the following:
 - Mark the precise orientation and position of all components before dismantling them.
 - Dismount components concentrically without canting.
 - Dismount pump (→ sectional drawing).

7.3.2 Dismantling SHM 20-15

1. Undo the screws (901.1).
2. Remove washers (554.1) and spring rings (934.1).
3. Remove the hydraulic unit complete with volute casing (102.1) and rear cover (817.1) from the motor bell housing (341.1).
4. Carefully remove the rear cover (817.1) from the volute casing (102.1).
5. Remove the sealing ring (412.5) from the rear cover (817.1).
6. Pull out shaft (210.1) with impeller (230.1), bearing bush (545.1) and thrust bearing (314.3 and 314.5) from the volute casing (102.1).
7. Remove the thrust bearings (314.3 and 314.5) from the shaft.
8. Remove the impeller (230) from the shaft (210.1).
9. Remove bearing bush (545.1) from the impeller (230.1).

7.3.3 Dismantling SHM 40-40 to 65-50

1. Attach lifting gear to the motor and gently lift.
2. Undo the screws (901.2).
3. Remove washers (554.2).
4. Remove the motor (801.1) with coupling housing (855.1) from the motor bell housing (341.1).
5. Undo the screws (901.1).
6. Remove washers (554.1) and spring rings (934.1).
7. Remove the hydraulic unit complete with volute casing (102.1) and rear cover (817.1) from the motor bell housing (341.1).
8. Carefully remove the rear cover (817.1) from the volute casing (102.1).
9. Remove the sealing ring (412.5) from the rear cover (817.1).
10. Pull out shaft (210.1) with impeller (230.1) and bearing bush (545.1) from the volute casing (102.1).
11. Remove the impeller (230.1) from the shaft (210.1).
12. Remove thrust bearing (314.3) from the volute casing.
13. Remove thrust bearing (314.4) from the impeller.
14. Remove thrust bearing (314.5) from the rear cover.
15. Remove bearing bush (545.1) from the impeller (230.1).

7.3.4 Dismantling of coupling housing

 Push the coupling housing (855.1) flush onto the motor shaft when assembling.

1. Unscrew stud bolt (904.1).
2. Remove coupling housing (855.1) from the motor shaft.

7.4 Replacement parts and return

1. Have the following information ready to hand when ordering spare parts (→ type plate).
 - Device type
 - ID number
 - Nominal pressure and diameter
 - Body and seal material
2. Please complete and enclose the document of compliance for returns (→ www.stuebbe.com/en/service/download).



3. Use only spare parts from Stübbe.

7.5 Installing

-  Install components concentrically and without tilting in accordance with the markings applied.

DANGER

Danger to life and material damage due to magnetic field.

- ▶ Make sure that personnel with pacemakers do not complete work on the pump.
- ▶ Secure the work place and if necessary cordon off:
 - Make sure that personnel with pacemakers keep a safe distance of > 1 m.
 - Make sure that no magnetizable metal parts can be attracted by the pump's magnetic coupling.
 - Make sure that parts of the magnetic coupling cannot be attracted by the magnetizable metal parts.
- ▶ Maintain a safe distance of at least 150 mm from the magnetic coupling for magnetically sensitive objects.

WARNING

Risk of injury due to heavy components!

- ▶ Pay attention to the component weight. Lift and transport heavy components using suitable lifting gear.
- ▶ Set down components safely and secure them against overturning or rolling away.

WARNING

Risk of injury during assembly!

- ▶ Install spring-loaded components carefully (e.g. mechanical seal, stressed bearing, valves etc.), as components can be ejected by the spring stress.
- ▶ Observe the manufacturer's specifications (e.g. for the motor, coupling, mechanical seal, blocking pressure system, cardan shaft, drives, belt drive etc.).

WARNING

Risk of injury during assembly work on the magnetic coupling!

- ▶ Use jacking screws to assemble the bearing bracket in order to prevent a sudden moving together of the magnetic coupling due to magnetic forces.

NOTE

Material damage due to incorrect dismounting/installation of the pump.

- ▶ Only specialist mechanics should complete dismounting/installation work.

NOTE

Material damage due to unsuitable components!

- ▶ Always replace lost or damaged screws with screws of the same strength where required (→ 9.2.8 Minimum flow rate, Page 33).
- ▶ Only replace seals with seals of the same material.

NOTE

Material damage, fragile components.

- ▶ Install ceramic parts of the plain bearing and magnets of the magnetic coupling with care, do not strike them or knock them.

1. When installing please observe:
 - Replace worn parts with genuine spare parts.
 - Replace seals, inserting them in such a way that they are unable to rotate.
 - Do not apply synthetic or mineral oil, grease or cleaning agents to elastomer components.
 - Adhere to the prescribed tightening torques (→ 9.2.8 Minimum flow rate, Page 33).
2. Installing the pump:
 - in reverse order to the dismounting (→ 7.3 Dismounting, Page 22).
 - → sectional drawing
3. Installing the pump in the system (→ 5 Disposal, Page 14).

8 Troubleshooting

 For pumps in potentially explosive atmospheres (→ ATEX additional manual).

DANGER

Danger to life and material damage due to magnetic field.

- ▶ Make sure that personnel with pacemakers do not complete work on the pump.
- ▶ Secure the work place and if necessary cordon off:
 - Make sure that personnel with pacemakers keep a safe distance of > 1 m.
 - Make sure that no magnetizable metal parts can be attracted by the pump's magnetic coupling.
 - Make sure that parts of the magnetic coupling cannot be attracted by the magnetizable metal parts.
- ▶ Maintain a safe distance of at least 150 mm from the magnetic coupling for magnetically sensitive objects.

If faults occur which are not specified in the following table or cannot be traced back to the specified causes, please consult the manufacturer.

Possible faults are identified by a fault number in the table below. This number identifies the respective cause and remedy in the troubleshooting list.

Fault	Number
Pump not pumping	1
Pumping rate insufficient	2
Pumping rate excessive	3
Pumping pressure insufficient	4
Pumping pressure excessive	5
Pump running roughly	6
Pump leaks	7
Excessive motor power uptake	8

Tab. 5 Fault/number assignment

Fault number								Cause	Remedy
1	2	3	4	5	6	7	8		
X	–	–	–	–	–	–	–	Intake / suction pipe and/or pressure line closed by fitting	▶ Open the fitting.
–	X	–	X	–	–	–	–	Intake / suction pipe not completely open	▶ Open the fitting.
X	X	–	X	–	X	–	–	Intake / suction pipe, pump or suction strainer blocked or encrusted	▶ Clean intake/suction pipe, pump or suction strainer.
–	X	–	X	–	X	–	–	Cross section of intake / suction pipe too narrow	▶ Increase cross section. ▶ Clean encrustation from suction pipe. ▶ Fully open fitting.
X	–	–	–	–	–	–	–	Transport and sealing cover still in place	▶ Remove the transport and sealing cover. ▶ Dismount the pump and inspect it for dry-running damage.

Fault number								Cause	Remedy
1	2	3	4	5	6	7	8		
-	X	-	X	-	X	-	-	Suction head too large: $NPSH_{\text{pump}}$ is larger than $NPSH_{\text{system}}$	<ul style="list-style-type: none"> ▶ Increase pump inlet pressure. ▶ Consult the manufacturer.
-	X	-	X	-	X	-	-	Back pressure of the system is too high, pump selected is too small.	<ul style="list-style-type: none"> ▶ Consult the manufacturer.
X	-	-	-	-	X	-	-	Intake/suction pipe and pump not correctly vented or not completely filled	<ul style="list-style-type: none"> ▶ Completely fill and vent pump and/or pipe.
X	-	-	-	-	X	-	-	Intake / suction pipe contains trapped air	<ul style="list-style-type: none"> ▶ Install fitting for venting. ▶ Adjust piping installation.
X	X	-	X	-	X	-	-	Air is sucked in	<ul style="list-style-type: none"> ▶ Seal source of problem.
X	X	-	X	-	X	-	-	Proportion of gas too high: pump is cavitating	<ul style="list-style-type: none"> ▶ Consult the manufacturer.
-	X	-	X	-	X	-	-	Temperature of fluid is too high: pump is cavitating	<ul style="list-style-type: none"> ▶ Increase pump inlet pressure. ▶ Lower temperature. ▶ Contact the manufacturer.
-	X	-	X	-	-	-	X	Viscosity or specific gravity of the pumped liquid outside the range specified for the pump	<ul style="list-style-type: none"> ▶ Consult the manufacturer.
-	X	-	X	-	-	-	-	Geodetic differential head and/or pipe flow resistances too high	<ul style="list-style-type: none"> ▶ Remove sediments from the pump and/or pressure pipe. ▶ Install a larger impeller and consult the manufacturer.
-	X	-	-	X	X	-	-	Pressure-side fitting not opened wide enough	<ul style="list-style-type: none"> ▶ Open the pressure-side fitting.
X	X	-	X	-	-	-	-	Magnetic coupling has parted	<ul style="list-style-type: none"> ▶ Switch off pump and switch on again.
X	X	-	-	X	X	-	-	Pressure pipe blocked	<ul style="list-style-type: none"> ▶ Clean the pressure pipe.
X	X	-	X	-	X	-	-	Pump running in the wrong direction	<ul style="list-style-type: none"> ▶ Change over any two phases in the motor.
X	X	-	X	-	-	-	-	Motor speed too low	<ul style="list-style-type: none"> ▶ Compare the required motor speed with the specifications on the pump type plate. Replace the motor if necessary. ▶ Increase the motor speed if speed control is available.
-	X	-	X	-	X	-	-	Pump parts worn	<ul style="list-style-type: none"> ▶ Replace the worn pump parts.
-	-	X	X	-	X	-	X	Pressure-side fitting opened too wide	<ul style="list-style-type: none"> ▶ Throttle down at the pressure-side fitting. ▶ Machine the impeller down. Consult the manufacturer and adjust the impeller diameter.
-	-	X	-	-	X	-	X	Geodetic differential head, pipe flow resistances and/or other resistances lower than specified	<ul style="list-style-type: none"> ▶ Throttle down the flow rate at the pressure-side fitting. Observe the minimum flow rate. ▶ Machine the impeller down. Consult the manufacturer and adjust the impeller diameter.
-	-	X	-	X	-	-	-	Viscosity lower than expected	<ul style="list-style-type: none"> ▶ Machine the impeller down. Consult the manufacturer and adjust the impeller diameter.

Fault number								Cause	Remedy
1	2	3	4	5	6	7	8		
-	-	X	-	X	X	-	X	Motor speed too high	<ul style="list-style-type: none"> ▶ Compare the required motor speed with the specifications on the pump type plate. Replace the motor if necessary. ▶ Reduce the motor speed if speed control is available.
-	-	X	-	X	X	-	X	Impeller diameter too large	<ul style="list-style-type: none"> ▶ Throttle down the flow rate at the pressure-side fitting. Observe the minimum flow rate. ▶ Machine the impeller down. Consult the manufacturer and adjust the impeller diameter.
X	X	-	X	-	X	-	-	Impeller out of balance or blocked	<ul style="list-style-type: none"> ▶ Dismount the pump and inspect it for dry-running damage. ▶ Clean the impeller.
-	X	-	X	-	X	-	-	Hydraulic parts of the pump dirty, clotted or encrusted	<ul style="list-style-type: none"> ▶ Dismount the pump. ▶ Clean the parts.
-	-	-	-	-	X	-	X	Plain bearing faulty	<ul style="list-style-type: none"> ▶ Replace plain bearing.
-	-	-	-	-	-	-	X	Defective antifriction bearing in motor	<ul style="list-style-type: none"> ▶ Replace the antifriction bearing (→ manufacturer's specifications).
-	-	-	-	-	-	-	-	Lubricant: too much, too little or unsuitable	<ul style="list-style-type: none"> ▶ Reduce, add to or replace lubricant.
-	-	-	-	-	-	X	-	Connecting bolts not correctly tightened	<ul style="list-style-type: none"> ▶ Tighten the connecting bolts.
-	-	-	-	-	-	X	-	Faulty housing seal	<ul style="list-style-type: none"> ▶ Replace the housing seal
-	-	-	-	-	X	X	X	Pump distorted	<ul style="list-style-type: none"> ▶ Check the pipe connections and pump attachment. ▶ Check alignment of coupling. ▶ Check attachment of the support foot.
-	X	-	X	-	X	-	X	Motor running on 2 phases	<ul style="list-style-type: none"> ▶ Check the fuse and replace it if necessary. ▶ Check the cable connections and insulation.

Tab. 6 Troubleshooting list

9 Appendix

9.1 Replacement parts

9.1.1 Part numbers and designations

Part no.	Designation
102.1	Volute casing
210.1	Shaft
230.1	Impeller
314.3	Axial bearing
314.4	Axial bearing
314.5	Axial bearing
341.01	Pump mounting bracket
412.1	Sealing ring
412.2	Sealing ring
412.5	Sealing ring
505.1	Reinforcement ring
545.1	Bearing bush
554.1	Washer
554.2	Washer
554.3	Washer
580.1	Protection cap
580.2	Protection cap
580.3	Protection cap
801.1	Motor
817.1	Rear cover
855.1	Bell housing
891.1	Base plate
901.1	Hexagon head bolt
901.2	Hexagon head bolt
901.3	Hexagon head bolt
904.1	Stud bolt
934.1	Spring ring
934.3	Spring ring
971.1	Rating plate

Tab. 7 Designation of components according to part numbers

9.1.2 Drawing SHM 20-15

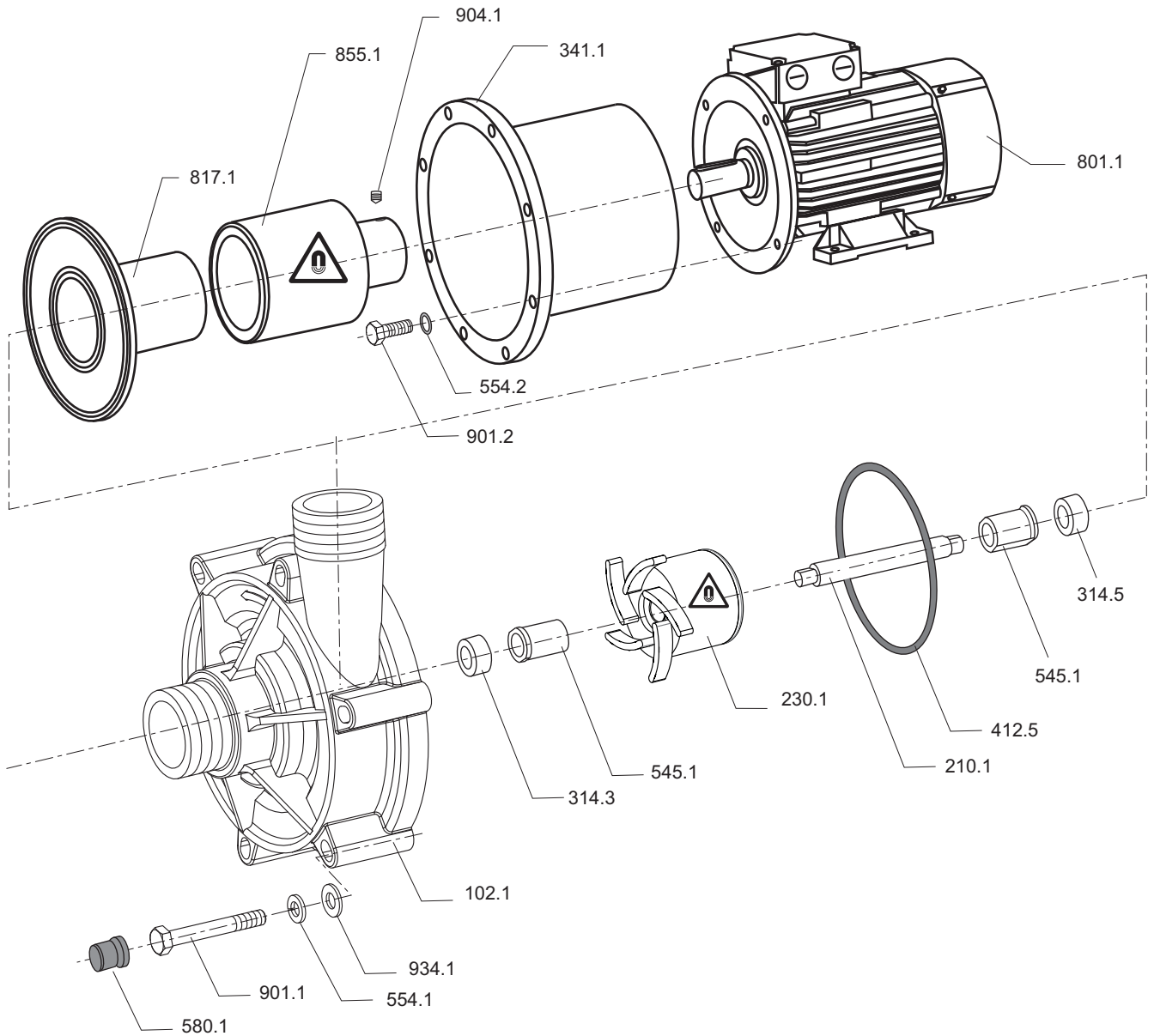

Fig. 7 Replacement parts SHM 20-15

9.1.3 Drawing SHM 40-40 to 65-50

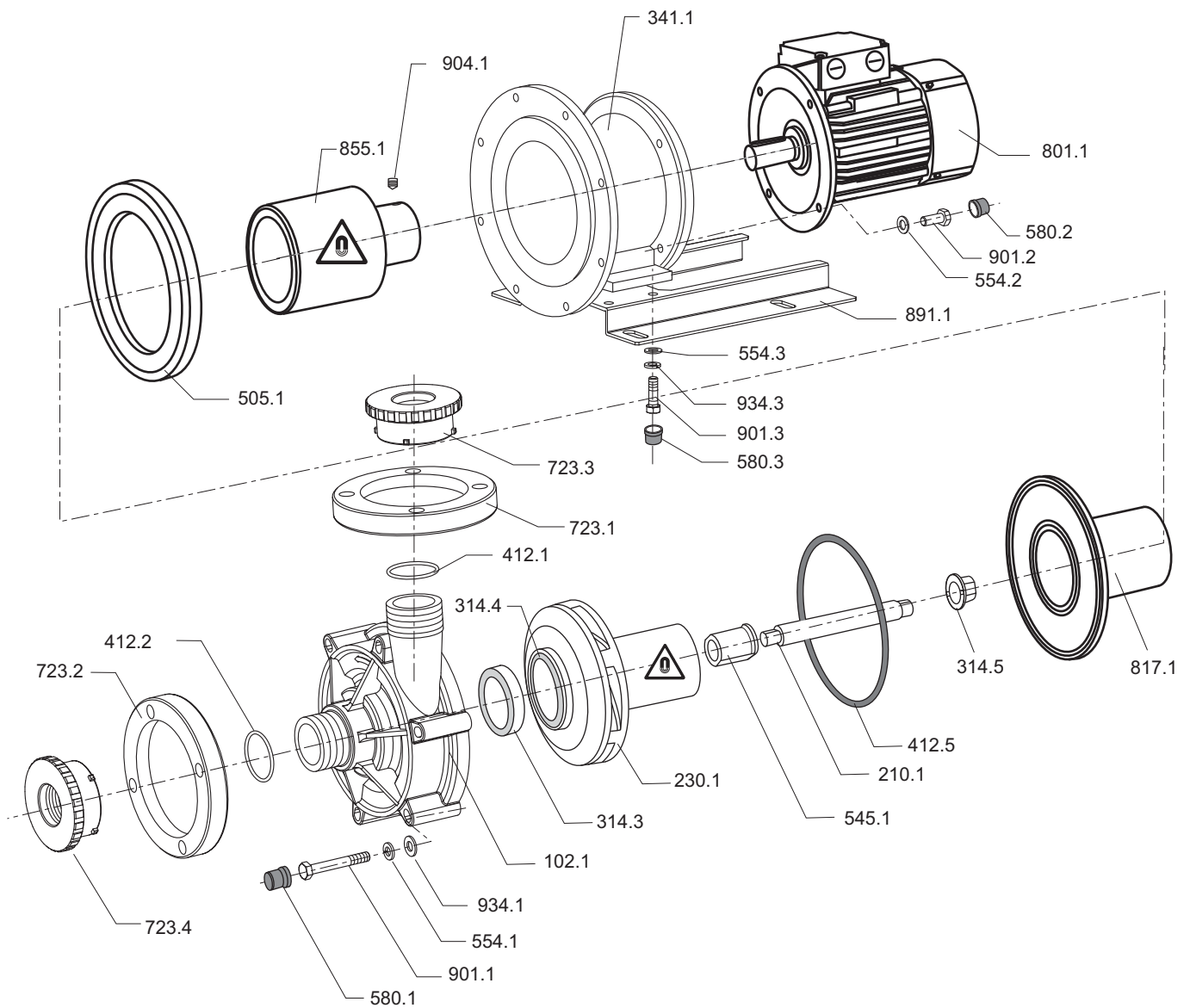



Fig. 8 Replacement parts SHM 40-40 to 65-50

9.2 Technical specifications

 Further technical data (→ data sheet).

9.2.1 Ambient conditions

 Operation under any other ambient conditions should be agreed with the manufacturer.

Temperature [°C]	Relative humidity [%]		Installation height above sea level [m]
	Long-term	Short-term	
-20 to +40 ¹⁾	≤ 85	≤ 100	≤ 1000

Tab. 8 Ambient conditions

1) material-dependent

9.2.2 Wear limits

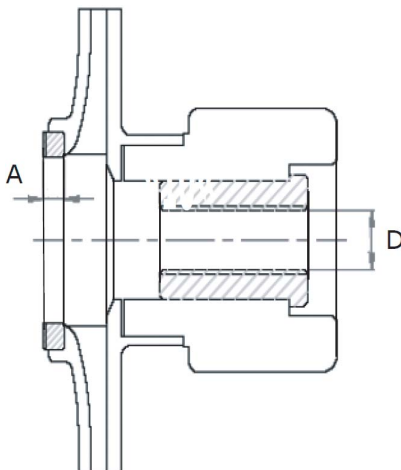

Fig. 9 Wear limits

A Axial bearing, thickness

D Bearing bush, inner diameter

	SHM 20-15		SHM 50-40 SHM 65-50	
	A [mm]	D [mm]	A [mm]	D [mm]
New dimension	6	15	7	18
Limit value	< 5	> 15.5	< 6	> 18.5

Tab. 9 Wear limits

9.2.3 Flange tightening torques

d [mm]	DN [mm]	Tightening torque ¹⁾ MD [Nm] for the versions		
		Flat sealing ring up to max 10 bar	Profile sealing ring up to max 16 bar	O-ring max. 16 bar
16	10	5	5	5
20	15	10	10	10
25	20	12	12	12
32	25	15	12	12
40	32	20	15	15
50	40	25	15	15
63	50	30	20	20
75	65	35	20	20

Tab. 10 Flange tightening torques

1) Use a torque wrench

9.2.4 Tightening torques of casing screws

Size	Part no.	Tightening torque [Nm]
20-15	901.1	6
	901.2	10
25-25	901.1	6
	901.2	10
40-40	901.1	6
	901.2	10
50-40	901.1	6
	901.2	10
65-50	901.1	6
	901.2	10

Tab. 11 Tightening torques of casing screws

9.2.5 Volumetric flow of liquid medium - minimum flow rate

Q_{min}	Short-time operation: $0.1 \times Q_{opt}$ (approx. 5 min.) Continuous operation: $0.15 \times Q_{opt}$
Q_{max}	See pump capacity curve (→ data sheet)
Q_{opt}	Volumetric flow in pump capacity curve efficiency optimum

Tab. 12 Volumetric flow of liquid medium

If operating point differs, consult the manufacturer.

9.2.6 Sound pressure level

Maximum noise level LpA for 2-pole 50Hz/60Hz motors, in dB (A)

Size SHM20-15, SHM40-40S und SHM40-40L

Motor power rating	0.18 kw		0.25 kw		0.37 kw		0.55 kw		0.75 kw		1.10 kw		1.5 kw	
	50 Hz	60 Hz	50 Hz	60 Hz	50 Hz	60 Hz	50 Hz	60 Hz	50 Hz	60 Hz	50 Hz	60 Hz	50 Hz	60 Hz
SHM20-15	50	53	50	53										
SHM40-40S					59	62	59	62	61	64				
SHM40-40L									61	64	61	64	66	69

Tab. 13 Maximum sound pressure level, sizes SHM20-15, SHM40-40S and SHM40-40L

Sizes SHM50-40S, SHM50-40L and SHM65-50

Motor power rating	1.5 kw		2.2 kw		3.0 kw		4.0 kw		5.5 kw		7.5 kw	
	50 Hz	60 Hz	50 Hz	60 Hz	50 Hz	60 Hz	50 Hz	60 Hz	50 Hz	60 Hz	50 Hz	60 Hz
SHM50-40S	66	69	66	69	68	71						
SHM50-40L			66	69	68	71	70	73				
SHM65-50							70	73	70	73	70	73

Tab. 14 Maximum sound pressure level, sizes SHM50-40S, SHM50-40L and SHM65-50

Measuring conditions:

- Distance to the pump: 1 m
- Operation: free of cavitation
- Motor: IEC standard motor
- Tolerance ± 3 dB
- Determination of the sound power by the sound intensity measurement method (DIN EN ISO 9614-2) and Determination of the workplace-related emission value (sound pressure level) LpA to DIN EN ISO 11203

9.2.7 Switching frequency

Motor power rating	Switch on / switch off actions per hour
0.18 kW \leq motors \leq 7.5 kW	15

Tab. 15 Switching frequency

9.2.8 Minimum flow rate

A minimum flow rate (Qmin) must be maintained in order to avoid impermissibly high temperatures and the pump overheating. The pump must be operated at the following minimum flow rate:

Construction type	Qmin [m ³ /h]
SHM20-15	0.5
SHM40-40S	2.0
SHM40-40L	2.5
SHM50-40S	3.5
SHM50-40L	4.0
SHM65-50	6.0

Tab. 16 Minimum flow rate

9.3 Maintenance schedule

Designation	Interval	Maintenance
Self-priming container	daily	▶ Check filling level.
Conveyed fluid	daily	▶ Check temperature ▶ Check discharge pressure.
Operating temperatures	Weekly	▶ Check motor temperature.
Undoable screwed connections	quarterly	▶ Check for correct and tight fitting.
Impeller Plain bearing Bearing bushes O-rings	As required	▶ Check components for wear and damage ▶ Clean or replace the impeller. ▶ Replace worn components

Tab. 17 Maintenance schedule

9.4 Declaration of conformity in accordance with EC machinery directive

EU Declaration of Conformity



Stübbe GmbH & Co. KG, Hollwieser Straße 5, 32602 Vlotho, Germany, declares on its own authority that the following products

Description
Centrifugal pumps with mechanical seal
NM, NMB, NX, SHB

Magnetically-coupled pumps
SHM

Eccentric pumps
Type F, Type L

Sump pumps
ET, ETL, ETLB, ETLB-S, ETLB-T, ETLB-ST

to which this declaration relates, are in conformity with the following standards:

Machinery Directive 2006/42/EC

EMC Directive 2014/30/EU

With regard to electrical hazards the protective aims of Low Voltage Directive 2014/35/EU have been complied with according to Appendix I no. 1.5.1 of the Machinery Directive 2006/42/EU.

Place and date

Vlotho, 25.01.2018

Name and signature of authorized person

pp Achim Kaesberg,
Manager Corporate Data