

Plastic Sump Pump

Original operating manual

Series
ETLB-S
ETLB-ST



Version BA-2018.01.25 EN
Print-No. 301 356
TR MA DE Rev001

ASV Stübbe GmbH & Co. KG
Hollwieser Straße 5
32602 Vlotho
Germany
Phone: +49 (0) 5733-799-0
Fax: +49 (0) 5733-799-5000
E-mail: contact@asv-stuebbe.de
Internet: www.asv-stuebbe.com



Subject to technical modifications.

Read carefully before use.
Save for future use.

Table of contents

1 About this document	4	5.6 Electrical connection	15
1.1 Target groups	4	5.6.1 Connecting the motor	15
1.2 Other applicable documents	4	5.6.2 Connecting the thermistor	15
1.3 Warnings and symbols	5	5.6.3 Check direction of rotation	15
2 Safety	6	5.7 Performing the hydrostatic test	15
2.1 Intended use	6	6 Operation	16
2.2 General safety instructions	6	6.1 Preparing for commissioning	16
2.2.1 Product safety	6	6.1.1 Check downtimes	16
2.2.2 Obligations of the operating company	7	6.1.2 Filling and bleeding	16
2.2.3 Obligations of personnel	7	6.2 Commissioning	16
2.3 Specific hazards	7	6.2.1 Switching on	16
2.3.1 Hazardous pumped liquids	7	6.2.2 Switching off	17
3 Layout and function	8	6.3 Shutting down the pump	17
3.1 Marking	8	6.4 Restoring the pump to service	18
3.1.1 Name plate	8	6.5 Operating the stand-by pump	18
3.2 Description	8	7 Maintenance	19
3.3 Assembly	8	7.1 Inspections	19
4 Transport, storage and disposal	9	7.2 Servicing	19
4.1 Transport	9	7.2.1 Maintenance in accordance with maintenance schedule	19
4.1.1 Unpacking and inspection on delivery	9	7.2.2 Cleaning the pump	19
4.1.2 Lifting	9	7.3 Dismounting	20
4.2 Storage	10	7.3.1 Preparations for dismounting	20
4.3 Disposal	10	7.3.2 Disassembly of spiral casing	21
5 Setup and connection	11	7.4 Replacement parts and return	21
5.1 Preparing for installation	11	7.5 Installing	22
5.1.1 Checking the operating conditions for the ETLB-S	11	8 Troubleshooting	23
5.1.2 Checking the operating conditions for the ETLB-ST	11	9 Appendix	25
5.1.3 Preparing the installation site	12	9.1 Replacement parts	25
5.1.4 Surface preparation	12	9.1.1 Part numbers and designations	25
5.2 Setting up	12	9.1.2 Sectional drawings	26
5.3 Planning pipelines	12	9.2 Technical specifications	31
5.3.1 Specifying supports and flange connections	12	9.2.1 Ambient conditions	31
5.3.2 Specifying nominal widths	12	9.2.2 Sole plate tightening torques	31
5.3.3 Optimizing changes of cross section and direction	12	9.2.3 Tightening torques of casing screws	31
5.3.4 Providing safety and control devices (recommended)	12	9.2.4 Filling heights and installation dimensions	31
5.4 Fitting the accessory part	13	9.2.5 Flange tightening torques	31
5.4.1 Preparing the accessory part	13	9.2.6 Permissible forces at the pressure socket	31
5.4.2 Checking the operating conditions for the accessory part	13	9.2.7 Sound pressure level	32
5.4.3 Fitting the accessory part	13	9.3 Maintenance schedule	32
5.5 Connecting the pipes	14	9.4 Declaration of conformity in accordance with EC machinery directive	33
5.5.1 Keeping the piping clean	14		
5.5.2 Installing the pressure pipe	14		
5.5.3 Inspection for stress-free pipe connections	14		

List of figures

Fig. 1	Name plate (example)	8
Fig. 2	Assembly	8
Fig. 3	Attaching lifting gear to the pump unit	9
Fig. 4	Mounting the ETLB-S pump on containers (example with suction extension)	11
Fig. 5	Mount the ETLB-ST pump on a supporting structure	11
Fig. 6	Installation of accessory parts	13
Fig. 7	Sectional view 1	26
Fig. 8	Sectional view 2	26
Fig. 9	Exploded drawing	26
Fig. 10	Sectional view 1	27
Fig. 11	Sectional view 2	27
Fig. 12	Exploded drawing	27
Fig. 13	Sectional view 1	28
Fig. 14	Sectional view 2	28
Fig. 15	Exploded drawing	28
Fig. 16	Sectional view 1	29
Fig. 17	Sectional view 2	29
Fig. 18	Exploded drawing	29
Fig. 19	Sectional view 1	30
Fig. 20	Sectional view 2	30
Fig. 21	Exploded drawing	30
Fig. 22	Permissible forces at the pressure socket	31

List of tables

Tab. 1	Other application documents, purpose and where found	4
Tab. 2	Warnings and symbols	5
Tab. 3	Measures to be taken if the pump is shut down	17
Tab. 4	Measures depending on the behavior of the pumped liquid	17
Tab. 5	Fault/number assignment	23
Tab. 6	Troubleshooting list	24
Tab. 7	Designation of components according to part numbers	25
Tab. 8	Ambient conditions	31
Tab. 9	Sole plate tightening torques	31
Tab. 10	Tightening torques of casing screws	31
Tab. 11	Tightening torques	31
Tab. 12	Noise level LpA to DIN EN ISO 11203	32
Tab. 13	Maintenance schedule	32

1 About this document

This manual:

- is part of the equipment
- applies to all series referred to
- describes safe and proper operation during all operating phases

1.1 Target groups

Operating company

- Responsibilities:
 - Always keep this manual accessible where the device is used on the system.
 - Ensure that employees read and observe this document, particularly the safety instructions and warnings, and the documents which also apply.
 - Observe any additional country-specific rules and regulations that relate to the system.

Qualified personnel, fitter







- Mechanics qualification:
 - Qualified employees with additional training for fitting the respective pipework
- Electrical qualification:
 - Qualified electrician
- Transport qualification:
 - Qualified transport specialist
- Responsibility:
 - Read, observe and follow this manual and the other applicable documents, especially all safety instructions and warnings.

1.2 Other applicable documents

To download: Resistance lists Resistance of materials used to chemicals	
www.asv-stuebbe.de/pdf_resistance/300051.pdf	
To download: Data sheet Technical data and conditions of operation	
www.asv-stuebbe.de/pdf_datasheets/300209.pdf	
To download: CE declaration of conformity Conformity with standards	
www.asv-stuebbe.de/pdf_DOC/300145.pdf	
Supplier documentation	Documentation included
<ul style="list-style-type: none"> • Technical documentation for parts supplied by subcontractors 	

Tab. 1 Other application documents, purpose and where found

1.3 Warnings and symbols

Symbol	Meaning
	<ul style="list-style-type: none"> • Immediate acute risk • Death, serious bodily harm
	<ul style="list-style-type: none"> • Potentially acute risk • Death, serious bodily harm
	<ul style="list-style-type: none"> • Potentially hazardous situation • Minor injury
	<ul style="list-style-type: none"> • Potentially hazardous situation • Material damage
	<p>Safety warning sign</p> <ul style="list-style-type: none"> ▶ Take note of all information highlighted by the safety warning sign and follow the instructions to avoid injury or death.
	Instruction
1., 2., ...	Multiple-step instructions
✓	Precondition
→	Cross reference
	Information, notes

Tab. 2 Warnings and symbols

2 Safety

 The manufacturer accepts no liability for damage caused by disregarding any of the documentation.

2.1 Intended use

- Only use the pump with suitable media (→ resistance lists).
- When using the pumps for solid particles, agree use in advance with the manufacturer.
- Do not use pump for combustible or explosive fluids.
- Adhere to the operating limits and size-dependent minimum flow rates.
- Avoid cavitation:
 - Open the suction-side fitting and do not use it to regulate the flow.
 - Do not open the pressure-side fitting beyond the agreed operating point.
- Avoid overheating:
 - Do not operate the pump while the pressure-side fitting is closed.
- Avoid damage to the motor:
 - Do not open the pressure-side fitting beyond the agreed operating point.
 - Note the maximum permissible number of times the motor can be switched on per hour (→ manufacturer's specifications).
- Only use the pump as part of large systems/tools.
- Consult with the manufacturer regarding any other use of the device.

Prevention of obvious misuse (examples)

- Observe pump limits of use regarding temperature, pressure, flow and speed (→ data sheet).
- The power consumption of the pump increases as the specific gravity of the pumped fluid increases. Adhere to the permissible specific gravity in order to eliminate the possibility that the pump, coupling and motor become overloaded (→ data sheet).
A lower specific gravity is permissible. Adapt the auxiliary systems accordingly.
- Pumps used with water as the pumped liquid must not be used for foodstuffs or drinking water. Use for food or drinking water only if specified in the data sheet.
- The type of installation should be selected only in accordance with these operating instructions. For example, the following are not allowed:
 - Hanging base plate pumps in the pipe
 - Overhead installation
 - Installation in the immediate vicinity of extreme heat or cold sources
 - Installation too close to a wall

2.2 General safety instructions

 Observe the following regulations before carrying out any work.

2.2.1 Product safety

The pump has been built according to state-of-the-art technology and the recognized technical safety regulations. Nevertheless, operation of the pump can still put the life and health of the user or third parties at risk or damage the pump or other property.

- Operate the pump only if it is in perfect technical condition and use it only as intended, staying aware of safety and risks, and in adherence to the instructions in this manual.
- Keep this manual and all other applicable documents complete, legible and accessible to personnel at all times.
- Refrain from any procedures and actions that would pose a risk to personnel or third parties.
- In the event of any safety-relevant faults, shut down the pump immediately and have the fault corrected by appropriate personnel.
- In addition to the entire documentation for the product, comply with statutory or other safety and accident-prevention regulations and the applicable standards and guidelines in the country where the pump is operated.

2.2.2 Obligations of the operating company

Safety-conscious working

- Operate the pump only if it is in perfect technical condition and use it only as intended, staying aware of safety and risks, and in adherence to the instructions in this manual.
- Ensure that the following safety aspects are observed and monitored:
 - Intended use
 - Statutory or other safety and accident-prevention regulations
 - Safety regulations governing the handling of hazardous substances
 - Applicable standards and guidelines in the country where the pump is operated
 - Applicable guidelines of the operator
- Make personal protective equipment available.

Qualified personnel

- Make sure all personnel tasked with work on the pump have read and understood this manual and all other applicable documents, especially the safety, maintenance and repair information, before they start any work.
- Organize responsibilities, areas of competence and the supervision of personnel.
- Ensure that all work is carried out by specialist technicians only:
 - Installation, repair and maintenance work
 - Transportation
 - Work on the electrical system
- Make sure that trainee personnel only work on the pump under supervision of specialist technicians.

Safety equipment

- Provide the following safety equipment and verify its functionality:
 - For hot, cold and moving parts: pump safety guarding provided by the customer
 - For pumps without capability to run dry: Dry run protection
 - For potential electrostatic charging: provide suitable grounding

Warranty

- Obtain the manufacturer's approval prior to carrying out any modifications, repairs or alterations during the warranty period.
- Only use genuine parts or parts that have been approved by the manufacturer.

2.2.3 Obligations of personnel

- All directions given on the pump must be followed (and kept legible), e.g. the arrow indicating the sense of rotation and the markings for fluid connections.
- Pump, coupling guard and components:
 - Do not step on them or use as a climbing aid
 - Do not use them to support boards, ramps or beams
 - Do not use them as a fixing point for winches or supports
 - Do not use them for storing paper or similar materials
 - Do not use the hot pump or motor components as a heating point
 - Do not de-ice the pump using gas burners or similar tools
- Do not remove the safety guarding for hot, cold or moving parts during operation.
- Use personal protective equipment if necessary.
- Only carry out work on the pump while it is not running.
- Before all installation and maintenance work, disconnect the motor from the mains and secure it against being switched back on again.
- Never reach into the suction or discharge flange.
- Following all work on the pump, refit safety devices in accordance with the instructions and bring into service.
- Do not make any modifications to the device.

2.3 Specific hazards

2.3.1 Hazardous pumped liquids

- When handling hazardous fluids, observe the safety regulations for the handling of hazardous substances.
- Use personal protective equipment when carrying out any work on the pump.
- Collect leaking pumped liquid and residues in a safe manner and damage them in accordance with environmental regulations.

3 Layout and function

3.1 Marking

3.1.1 Name plate

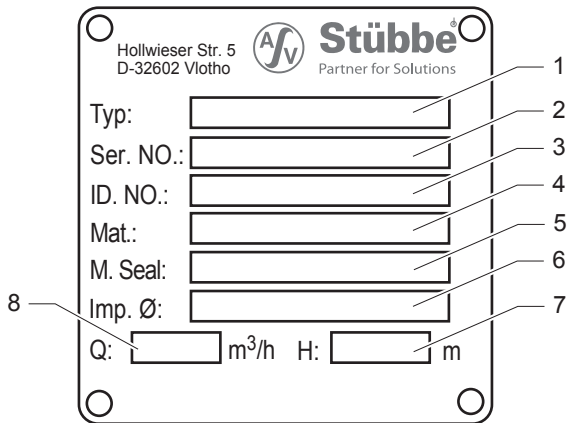

Fig. 1 Name plate (example)

- 1 Pump type
- 2 Serial number
- 3 Ident. number
- 4 Housing / sealing material
- 5 Shaft seal information
- 6 Impeller diameter [mm]
- 7 Differential head
- 8 Flow

3.2 Description

Non self-priming, vertical centrifugal pump in modular design. Use in open or closed unpressured containers or pits/trenches. The pump is dry-running safe.

3.3 Assembly

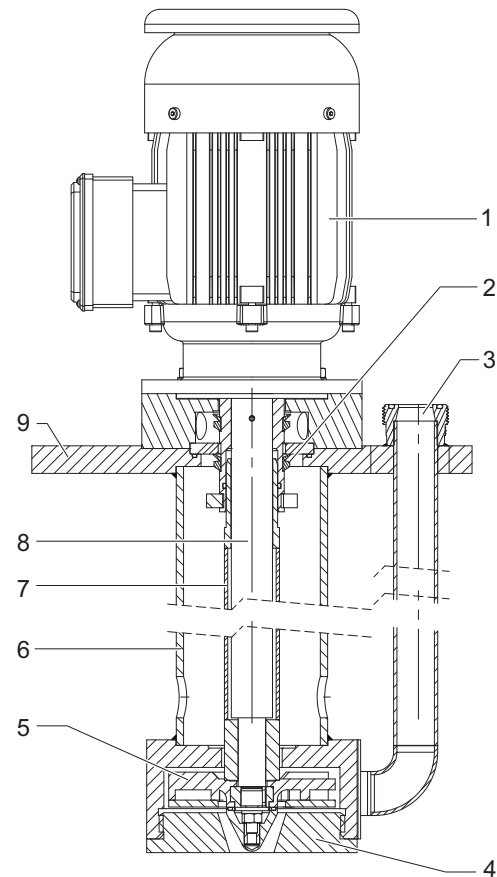



Fig. 2 Assembly

- 1 Motor
- 2 V-ring
- 3 Discharge flange
- 4 Volute casing
- 5 Impeller
- 6 Immersion tube
- 7 Protection tube
- 8 Shaft
- 9 Sole plate

4 Transport, storage and disposal

4.1 Transport

 The user/owner is responsible for the transport of the pump.

 Weight specifications (→ documents for the particular order)

4.1.1 Unpacking and inspection on delivery

1. Unpack the pump/pump assembly upon delivery and inspect it for transport damage.
2. Check completeness and accuracy of delivery.
3. Ensure that the information on the name plate agrees with the order/design data.
4. Report any transportation damage to the manufacturer immediately.
5. Dispose of packaging material according to local regulations.

 Retain the transport frame for horizontal storage (recommended).

4.1.2 Lifting

 **DANGER**

Death or limbs crushed as a result transported items falling over!

- ▶ Use lifting gear appropriate for the total weight to be transported.
- ▶ Attach lifting gear in accordance with the following diagrams.
- ▶ Never use the lifting eye of the motor as the attachment point for lifting the entire pump (the lifting eye of the motor may be used for securing a pump assembly with a high center of gravity against being knocked over).
- ▶ Do not stand under suspended loads.

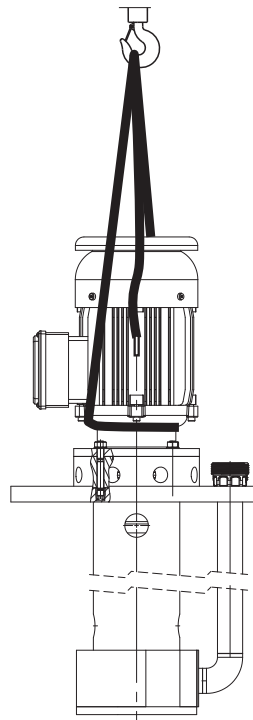

Fig. 3 Attaching lifting gear to the pump unit

1. Attach lifting gear in accordance with the above diagram.
2. Lift the pump/pump assembly appropriately.

4.2 Storage

DANGER

Death or limbs crushed as a result of the pump overturning!

- ▶ For vertical storage:
 - Place pump on a horizontal underground and secure against overturning.

NOTE

Material damage due to inappropriate storage!

- ▶ Store the pump properly.
1. Seal all openings with blind flanges, blind plugs or plastic covers.
 2. Make sure the storage room meets the following conditions:
 - Dry
 - Frost-free
 - Vibration-free
 - UV protected
 3. For horizontal storage:
 - Protect pump against sagging by means of proper support.
 4. Rotate the pump shaft twice a month.
 5. Make sure the shaft and bearing change their rotational position in the process.

4.3 Disposal

-  Plastic parts can be contaminated by poisonous or radioactive pumped liquids to such an extent that cleaning will be insufficient.

WARNING

Risk of poisoning and environmental damage by the pumped liquid or oil!

- ▶ Use personal protective equipment when carrying out any work on the pump.
 - ▶ Prior to the disposal of the pump:
 - Collect and damage any escaping pumped liquid or oil in accordance with local regulations.
 - Neutralize residues of pumped liquid in the pump.
 - ▶ Remove plastic parts and damage them in accordance with local regulations.
-
- ▶ Dispose of the pump in accordance with local regulations.

5 Setup and connection

NOTE

Material damage due to distortion or passage of electrical current in the bearing!

- ▶ Do not make any structural modifications to the pump assembly or pump casing.
- ▶ Do not carry out any welding work on the pump assembly or pump casing.

NOTE

Material damage caused by dirt!

- ▶ Do not remove the transport seals until immediately before installing the pump.
- ▶ Do not remove any covers or transport and sealing covers until immediately before connecting the pipes to the pump.

5.1 Preparing for installation

5.1.1 Checking the operating conditions for the ETLB-S

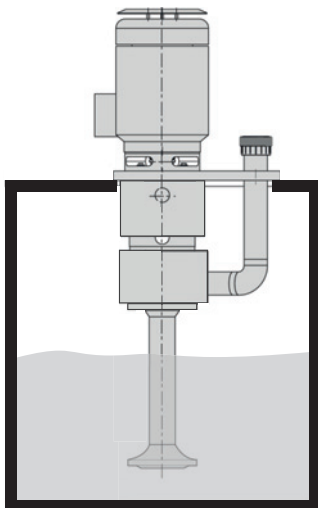

Fig. 4 Mounting the ETLB-S pump on containers (example with suction extension)

1. Ensure the required operating conditions are met:
 - Resistance of body and seal material to the medium (→ Resistance lists).
 - Required ambient conditions (→ 9.2.1 Ambient conditions, Page 31).
2. Ensure necessary dimensions for tank cut-out (→ data sheet).
3. Ensure safe aeration and venting of the container in all operating phases.
4. Ensure the required installation dimensions and filling levels are satisfied (→ data sheet).
 - Minimum distances
 - Maximum filling height
 - Minimum filling height

5.1.2 Checking the operating conditions for the ETLB-ST

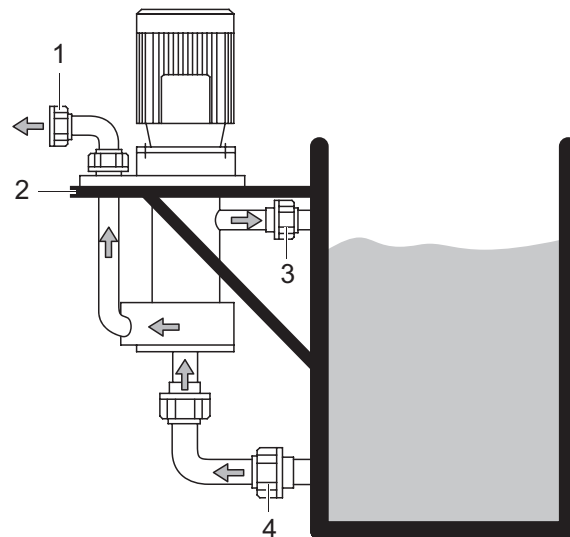

Fig. 5 Mount the ETLB-ST pump on a supporting structure

- 1 Process connector on the pressure side
 - 2 Supporting structure
 - 3 Overrun/return of rising medium in the suspension pipe
 - 4 Suction pipe/inlet to pump
1. Ensure the required operating conditions are met:
 - Resistance of body and seal material to the medium (→ resistance lists).
 - Required ambient conditions (→ 9.2.1 Ambient conditions, Page 31).
 2. Provide an appropriate supporting structure with the required dimensions for the pump support (→ data sheet). Guarantee the following conditions for the supporting structure:
 - Level and horizontal
 - Clean (no oil, dust or other impurities)
 - Capable of bearing the weight of the pump assembly and all operating forces
 - Stability of the pump ensured
 - Resonance-free
 3. Ensure safe aeration and venting of the container in all operating phases.
 4. Ensure the required installation dimensions and filling levels are satisfied (→ data sheet).
 - Minimum distances
 - Maximum filling height
 - Minimum filling height
 5. Clean containers, basins or pits carefully and protect from further contamination, e.g. by installing an overflow containment wall in front of the container or pit inlet.

5.1.3 Preparing the installation site

- ▶ Ensure the installation site meets the following conditions:
 - Pump is freely accessible from all sides
 - Sufficient space for the installation/removal of the pipes and for maintenance and repair work, especially for the removal and installation of the pump and the motor
 - Pump not exposed to external vibration (damage to bearings)
 - No corrosive exposure
 - Frost protection

5.1.4 Surface preparation

- ✓ Aids, tools, materials:
 - Spirit level
- 1. Make sure the surface meets the following conditions:
 - Level and horizontal
 - Clean (no oil, dust or other impurities)
 - Capable of bearing the weight of the pump assembly and all operating forces
 - Stability of the pump ensured
 - Resonance-free
- 2. Clean containers, basins or pits carefully and protect from further contamination, e.g. by installing overflow wall in front of the container or pit inlet.

5.2 Setting up

1. Remove the suction-side cover if present.
2. Lift pump/pump assembly (→ [4.1 Transport, Page 9](#)).
3. Place pump/pump assembly on the contact surface of the container/pit.
4. Attach sole plate to the contact surface.
 - Pump must not be mechanically under stress as a result of being attached
5. Screw on the sole plate (→ [9.2.2 Sole plate tightening torques, Page 31](#)).

5.3 Planning pipelines

-  Water hammer may damage the pump or the system. Plan the pipes and fittings as far as possible to prevent water hammer occurring.

5.3.1 Specifying supports and flange connections

NOTE

Material damage due to excessive forces and torques on the pump.

- ▶ Ensure pipe connection without stress.

1. Plan pipes safely:
 - No pulling or thrusting forces
 - No bending moments
 - Adjust for changes in length due to temperature changes (compensators, expansion shanks)
 - Optional installation position
2. Support pipes in front of the pump.
3. Ensure the pipe supports have permanent low-friction properties and do not seize up due to corrosion.

5.3.2 Specifying nominal widths

-  Keep the flow resistance in the pipes as low as possible.

1. Make sure the suction extension is not smaller than the nominal width of the suction branch.
2. Make sure the nominal pressure line width is not smaller than the nominal discharge flange width.
 - Ensure the flow velocity is less than 3 m/s.

5.3.3 Optimizing changes of cross section and direction

1. Avoid radii of curvature of less than 1.5 times the nominal pipe diameter.
2. Avoid abrupt changes of cross-section along the piping.

5.3.4 Providing safety and control devices (recommended)

Avoid reverse running

1. Install a non-return valve between the discharge flange and stop valve, to ensure that the medium does not flow back after the pump is switched off.
2. In order to enable venting, include vent connection between discharge flanges and non-return valve.

Make provisions for isolating and shutting off the pipes

-  For maintenance and repair work.

- ▶ Provide shut-off devices in the pressure pipe.

Allow measurements of the operating conditions

1. Provide a pressure gauge in the pressure line for pressure measurement.
2. Provide pressure measurement on the pump side.

5.4 Fitting the accessory part

5.4.1 Preparing the accessory part

1. Unpack the accessory part when received and inspect it for transportation damage.
2. Report any transportation damage to the manufacturer immediately.
3. For immediate installation, damage packaging material according to local regulations. If installation is not to be performed until a later time, leave the accessory part in its original packaging.

5.4.2 Checking the operating conditions for the accessory part

1. Ensure the necessary installation dimensions and filling level of the pump with the accessory part installed (→ data sheet):
 - Minimum distances
 - Maximum filling height
 - Minimum filling height
2. Ensure that the substrate or container can take the weight of the pump bearing the accessory part.

5.4.3 Fitting the accessory part

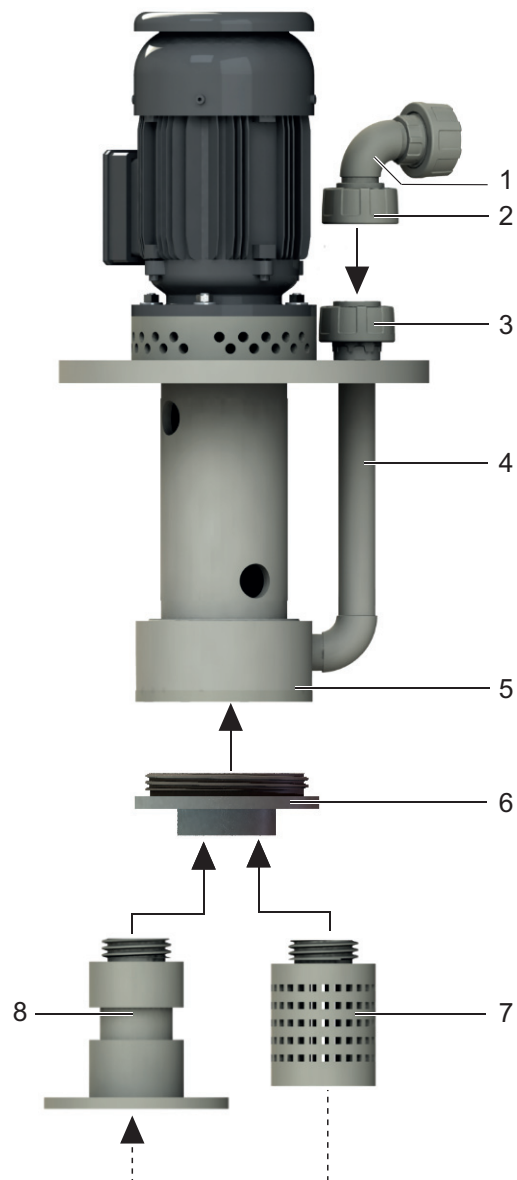



Fig. 6 Installation of accessory parts

- 1 Discharge elbow / flange adapter
- 2 Union nut
- 3 Union nut
- 4 Discharge flange
- 5 Volute casing
- 6 Adapter
- 7 Suction strainer
- 8 Suction extension

Installing a suction extension and suction strainer

 If required the suction extension or the suction strainer can be installed in the adapter. Optionally the suction strainer can be installed in the suction extension.

- ✓ Accessory part prepared
 - ✓ Operating conditions for the accessory part checked
 - ✓ Tool and material:
 - Face wrench (125/6 AF)
1. Using the face wrench, unscrew the volute casing cover clockwise from the volute casing (5). Note this is a left-hand thread.
 2. Using the face wrench, screw the adapter (6) finger-tight into the left-hand thread of the volute casing (5). In doing so, ensure the following:
 - The sealing ring is positioned correctly
 - Do not install the sealing ring dry
 3. Depending on the installation situation, proceed as follows:
 - When installing the suction extension (8): screw the suction extension (8) finger-tight into the adapter (6). Note this is a right-hand thread.
 - If necessary, screw the suction strainer (7) finger-tight into the suction extension (8).
 - OR –
 - When installing the suction strainer (7): screw the suction strainer (7) finger-tight into the adapter (6). Note this is a right-hand thread.

Installing the discharge elbow / flange adapter

- ✓ Accessory part prepared
 - ✓ Operating conditions for the accessory part checked
1. Unscrew the union nut (3) from the discharge flange (4). If necessary, remove the insert from the discharge flange (4).
 2. Position the discharge elbow / flange adapter (1) on the discharge flange (4) and align it.
 3. Using the union nuts (2), bolt the discharge elbow / flange adapter (1) finger-tight to the discharge flange (4).

5.5 Connecting the pipes

NOTE

Material damage due to excessive forces and torques on the pump.

- ▶ Ensure pipe connection without stress.
-

5.5.1 Keeping the piping clean

NOTE

Material damage due to impurities in the pump!

- ▶ Make sure no impurities can enter the pump.
-

1. Clean all piping parts and fittings prior to assembly.
2. Flush all pipes carefully with neutral medium.
3. Ensure no flange seals protrude inwards.
4. Remove any blind flanges, plugs, protective foils and/or protective paint from the flanges.

5.5.2 Installing the pressure pipe

1. Remove the transport and sealing covers from the pump.
2. Fit the pressure line stress-free and sealed
3. Ensure no seals protrude inwards.

5.5.3 Inspection for stress-free pipe connections

- ✓ Piping installed and cooled down
1. Disconnect the pipe connecting flanges from the pump.
 2. Check whether the pipes can be moved freely in all directions within the expected range of expansion:
 - Nominal width < 150 mm: by hand
 - Nominal width > 150 mm: with a small lever
 3. Make sure the flange surfaces are parallel.
 4. Reconnect the pipe connecting flanges to the pump.
 5. If present, check support foot for stress.

5.6 Electrical connection

DANGER

Risk of electrocution!

- ▶ All electrical work must be carried out only by qualified electricians.
- ▶ Before all work on the electrical system, disconnect the motor from the mains and secure against being switched back on again.

5.6.1 Connecting the motor

 Follow the instructions of the motor manufacturer.

1. Connect the motor according to the connection diagram.
2. Make sure no danger arises due to electric power.
3. Install an EMERGENCY STOP switch.

5.6.2 Connecting the thermistor

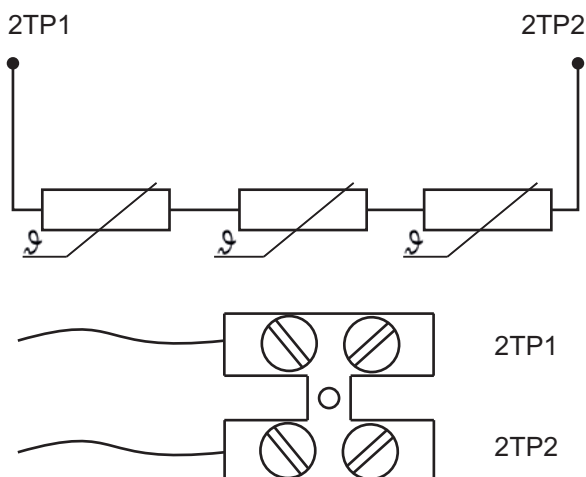

- ▶ Connect the PTC thermistor to the motor protector.
 - Activation temperature 155°C
 - Test voltage 2.5 V

5.6.3 Check direction of rotation

DANGER

Danger to life from rotating parts.

- ▶ Use personal protective equipment when carrying out any work on the pump.
- ▶ Maintain an adequate distance from rotating parts.

1. Switch on motor for max. 2 seconds and switch it off again immediately.
2. Check whether the sense of rotation of the motor matches the direction of rotation on the fan impeller.
3. If the sense of rotation is different: Change over any two phases.

5.7 Performing the hydrostatic test

 Only necessary if the entire system needs to be tested under pressure.

NOTE

Material damage due to bursting of pump casing.

- ▶ Testing pressure must not exceed the permissible pump pressure (→ documents for the particular order).
- ▶ Make sure the testing pressure does not exceed the permissible pump pressure.
 - If necessary, do not perform pressure test on the pump.

6 Operation

6.1 Preparing for commissioning

6.1.1 Check downtimes

- ▶ Check downtimes (→ 6.4 Restoring the pump to service, Page 18).

6.1.2 Filling and bleeding

⚠ WARNING

Risk of injury and poisoning due to hazardous pumped liquids!

- ▶ Use protective equipment for any work on the pump.
- ▶ Collect leaking liquid safely and damage fitting in accordance with local regulations.

1. Close the pressure-side fitting.
2. Fill pump and, if present, suction pipe with fluid. Ensure minimum filling height when doing so
3. Verify that no pipe connections are leaking.

6.2 Commissioning

6.2.1 Switching on

- ✓ Pump set up and connected properly
- ✓ Motor set up and connected properly
- ✓ All connections stress-free and sealed
- ✓ All safety equipment installed and tested for functionality
- ✓ Pump prepared, filled and vented correctly
- ✓ Container is filled sufficiently up to minimum height “Z” (→ 9.2.4 Filling heights and installation dimensions, Page 31).

⚠ DANGER

Risk of injury due to running pump!

- ▶ Do not touch the pump when it is running.
- ▶ Do not carry out any work on the pump when it is running.
- ▶ Allow the pump to cool down completely before starting any work.

⚠ DANGER

Risk of injury and poisoning due to pumped liquid spraying out!

- ▶ Use personal protective equipment when carrying out any work on the pump.

NOTE

Risk of cavitation if suction flow is restricted!

- ▶ Open the suction-side fitting and do not use it to regulate the flow.
- ▶ Do not open the pressure-side fitting beyond the operating point.

NOTE

Material damage due to overheating.

- ▶ Do not operate the pump for long periods with the pressure-side fitting closed.
- ▶ Observe minimum flow (→ order data sheet).

1. Open the suction-side fitting.
2. Close the pressure-side fitting.
3. Switch on the motor and check it for smooth running.
4. Once the motor has reached its nominal speed, open the pressure-side fitting slowly until the operating point is reached.
5. Make sure temperature change is smaller than 5 K/min for pumps with hot fluids.
6. After the initial stress due to the pressure and operating temperature, check that the pump is not leaking.

6.2.2 Switching off

- ✓ Pressure-side fitting closed (recommended)

WARNING

Risk of injury due to hot pump parts!

- ▶ Use personal protective equipment when carrying out any work on the pump.

1. Switch off motor.
2. Check all connecting bolts and tighten them if necessary (only after initial commissioning).

6.3 Shutting down the pump

DANGER

Risk of injury due to running pump!

- ▶ Do not touch the pump when it is running.
- ▶ Do not carry out any work on the pump when it is running.
- ▶ Before all installation and maintenance work, disconnect the motor from the mains and secure it against being switched back on again.

DANGER

Risk of electrocution!

- ▶ All electrical work must be carried out only by qualified electricians.
- ▶ Before all work on the electrical system, disconnect the motor from the mains and secure against being switched back on again.

WARNING

Risk of injury and poisoning due to hazardous pumped liquids!

- ▶ Use protective equipment for any work on the pump.
- ▶ Collect leaking liquid safely and damage fitting in accordance with local regulations.

- ▶ Take the following measures whenever the pump is shut down:

Pump is	Action
shut down	▶ Take measures appropriate for the fluid (→ Table 4 Measures depending on the behavior of the pumped liquid, Page 17).
...emptied	▶ Close suction and pressure-side fitting.
...dismounted	▶ Isolate the motor from its power supply and secure it against unauthorized switch-on.
...put into storage	▶ Note measures for storage.

Tab. 3 Measures to be taken if the pump is shut down

Behavior of the pumped liquid	Duration of shutdown (depending on process)	
	Short	Long
Crystallized or polymerized, solids sedimenting	▶ Flush the pump.	▶ Flush the pump.
Solidifying/freezing, non-corrosive	▶ Heat up or empty the pump and containers.	▶ Empty the pump and containers.
Solidifying/freezing, corrosive	▶ Heat up or empty the pump and containers.	▶ Empty the pump and containers.
Remains liquid, non-corrosive	–	–
Remains liquid, corrosive	–	▶ Empty the pump and containers.

Tab. 4 Measures depending on the behavior of the pumped liquid

6.4 Restoring the pump to service

1. Complete all steps as for commissioning ([→ 6.2 Commissioning, Page 16](#)).
2. If the pump is shut down for over 1 year, replace elastomer seals (O-rings, shaft sealing rings).

6.5 Operating the stand-by pump

✓ Stand-by pump filled and bled

 Operate the stand-by pump at least once a week.

- ▶ Open pressure-side fitting far enough so that the stand-by pump operating temperature is achieved and heating is even ([→ 6.2.1 Switching on, Page 16](#)).

7 Maintenance

 Trained service technicians are available for fitting and repair work. Submit evidence of conveyed medium on request (DIN safety data sheet or safety certificate).

7.1 Inspections

 The inspection intervals depend on the operational strain on the pump.

DANGER

Risk of injury due to running pump!

- ▶ Do not touch the pump when it is running.
- ▶ Do not carry out any work on the pump when it is running.

WARNING

Risk of injury and poisoning due to hazardous pumped liquids!

- ▶ Use protective equipment for any work on the pump.

1. Check at appropriate intervals:
 - Adherence to the minimum flow rate
 - Normal operating conditions unchanged
 - Filling level of the container
2. For trouble-free operation, always ensure the following:
 - No leaks
 - No cavitation
 - Free and clean filters
 - No unusual running noises or vibrations
 - No inadmissible leaks on the shaft seal

7.2 Servicing

 Operating life of antifriction bearings in operation are within permissible range: >2 years.

Intermittent operation, high temperatures, low viscosities and aggressive ambient and process conditions reduce the service life of antifriction bearings.

 Plain bearings are subject to natural wear and tear which is heavily dependent on the respective operating conditions. It is therefore not possible to make general statements about the operating life.

DANGER

Risk of injury due to running pump!

- ▶ Do not touch the pump when it is running.
- ▶ Do not carry out any work on the pump when it is running.
- ▶ Before all installation and maintenance work, disconnect the motor from the mains and secure it against being switched back on again.

DANGER

Risk of electrocution!

- ▶ All electrical work must be carried out only by qualified electricians.
- ▶ Before all work on the electrical system, disconnect the motor from the mains and secure against being switched back on again.

WARNING

Risk of injury and poisoning due to hazardous or hot fluid!

- ▶ Use protective equipment for any work on the pump.
- ▶ Allow the pump to cool down completely before commencing any work.
- ▶ Make sure the pump is depressurized.
- ▶ Empty the pump, safely collect the pumped liquid and damage it in accordance with environmental rules and requirements.

7.2.1 Maintenance in accordance with maintenance schedule

- ▶ Perform maintenance work in accordance with the maintenance schedule (→ [9.3 Maintenance schedule, Page 32](#)).

7.2.2 Cleaning the pump

NOTE

High water pressure or spray water can damage bearings!

- ▶ Do not clean bearing areas with a water or steam jet.
- ▶ Clean large-scale grime from the pump.

7.3 Dismounting

DANGER

Risk of injury due to running pump!

- ▶ Do not touch the pump when it is running.
- ▶ Do not carry out any work on the pump when it is running.
- ▶ Before all installation and maintenance work, disconnect the motor from the mains and secure it against being switched back on again.

DANGER

Risk of electrocution!

- ▶ All electrical work must be carried out only by qualified electricians.
- ▶ Before all work on the electrical system, disconnect the motor from the mains and secure against being switched back on again.

DANGER

Death or limbs crushed as a result of the pump overturning.

- ▶ Place pump on a horizontal underground and secure against overturning.

WARNING

Risk of injury and poisoning due to hazardous or hot fluid!

- ▶ Use protective equipment for any work on the pump.
- ▶ Allow the pump to cool down completely before commencing any work.
- ▶ Make sure the pump is depressurized.
- ▶ Empty the pump, safely collect the pumped liquid and damage it in accordance with environmental rules and requirements.

WARNING

Risk of injury due to heavy components!

- ▶ Pay attention to the component weight. Lift and transport heavy components using suitable lifting gear.
- ▶ Set down components safely and secure them against overturning or rolling away.

WARNING

Risk of injury during disassembly!

- ▶ Secure the pressure-side gate valve against accidental opening.
- ▶ Depressurize the blocking pressure system, if available.
- ▶ Wear protective gloves, components can become very sharp-edged due to wear or damage.
- ▶ Remove spring-loaded components carefully (e.g. mechanical seal, stressed bearing, valves etc.), as components can be ejected by the spring stress.
- ▶ Observe the manufacturer's specifications (e.g. for the motor, coupling, mechanical seal, blocking pressure system, cardan shaft, drives, belt drive etc.).

NOTE

Material damage due to incorrect dismounting/installation of the pump.

- ▶ Only specialist mechanics should complete dismounting/installation work.

7.3.1 Preparations for dismounting

- ✓ Pump is depressurized
- ✓ Pump completely empty, flushed and decontaminated
- ✓ Electrical connections disconnected and motor secured against switch-on
- ✓ Pump cooled down
- ✓ Pressure gauge lines, pressure gauge and fixtures dismounted
- ▶ When dismounting, observe the following:
 - Mark the precise orientation and position of all components before dismounting them.
 - Dismount components concentrically without canting.
 - Dismount pump (→ sectional drawing).

7.3.2 Disassembly of spiral casing

Removal of the hydraulic system, size 15–60

1. Undo the housing cover (161.01) with left-hand thread.
2. Undo the impeller cap (260.01).
3. Undo the hexagon screw (914.01).
4. Pull the impeller with shaft protection tube (230.01) off the motor shaft.

Removal of the hydraulic system, other sizes

1. Undo the housing cover (161.01) with left-hand thread.
2. Undo the impeller cap (260.01).
3. Undo the nut (920.02) with circlip (934.01) and washer (550.01).
4. Remove the impeller together with shaft protection tube (230.01) from the motor shaft and keep key (940.01).

Removal of the V-rings, one sealing washer

 Sizes 15-60; 20-100; 25-125S; 25-125L; 32-125; 40-125; 32-125

1. Complete steps 1- 4 of hydraulic system disassembly.
2. Undo hexagon nut (920.01) with washer (554.01).
3. Pull the suspension pipe (713.01) to the bottom.
4. Remove the centrifugal disk (558.01) if available.
5. Undo the V rings (507.01) and sealing washer (444.01).

Removal of the V-rings, two sealing washers

 Sizes 32-160 5,5/7,5kW; 40-160 5,5/7,5kW; 50-125 5,5/7,5kW; 32-160 4,0kW; 40-160 4,0kW; 50-125 4,0kW; 80-200

1. Complete steps 1- 4 of hydraulic system disassembly.
2. Undo the screw (901.01) with washer (554.02).
3. Pull the suspension pipe (713.01) to the bottom.
4. Undo the hexagon screws (914.04).
5. Undo the lower sealing washer (444.01), the lower V-ring (507.01) and the intermediate ring (509.01).
6. Pull off downwards the sealing flange (490.01) with upper sealing washer (444.02).
7. Undo the upper V-ring (507.01).

7.4 Replacement parts and return

1. Have the following information ready to hand when ordering spare parts
 - Device type
 - ID number
 - Nominal pressure and diameter
 - Connection and gasket material
2. Please complete and enclose the document of compliance for returns
(→ www.asv-stuebbe.de/pdf_DOC/300359.pdf).



7.5 Installing

 Install components concentrically and without tilting in accordance with the markings applied.

WARNING

Risk of injury due to heavy components!

- ▶ Pay attention to the component weight. Lift and transport heavy components using suitable lifting gear.
- ▶ Set down components safely and secure them against overturning or rolling away.

WARNING

Risk of injury during assembly!

- ▶ Install spring-loaded components carefully (e.g. mechanical seal, stressed bearing, valves etc.), as components can be ejected by the spring stress.
- ▶ Observe the manufacturer's specifications (e.g. for the motor, coupling, mechanical seal, blocking pressure system, cardan shaft, drives, belt drive etc.).

NOTE

Material damage due to incorrect dismantling/installation of the pump.

- ▶ Only specialist mechanics should complete dismantling/installation work.

NOTE

Material damage due to unsuitable components!

- ▶ Always replace lost or damaged screws with screws of the same strength where required.
- ▶ Only replace seals with seals of the same material.

NOTE

Material damage, fragile components.

- ▶ Install ceramic parts of the plain bearing and magnets of the magnetic coupling with care, do not strike them or knock them.

1. When installing please observe:
 - Replace worn parts with genuine spare parts.
 - Replace seals, inserting them in such a way that they are unable to rotate.
 - Do not apply synthetic or mineral oil, grease or cleaning agents to elastomer components.
 - Adhere to the prescribed tightening torques ([→ 9.2.3 Tightening torques of casing screws, Page 31](#)).

2. Installing the pump:
 - in reverse order to the dismantling ([→ 7.3 Dismounting, Page 20](#)).
 - [→ sectional drawing](#)
3. Installing the pump in the system ([→ 5 Setup and connection, Page 11](#)).

8 Troubleshooting

If faults occur which are not specified in the following table or cannot be traced back to the specified causes, please consult the manufacturer.

Possible faults are identified by a fault number in the table below. This number identifies the respective cause and remedy in the troubleshooting list.

Fault	Number
Pump not pumping	1
Pumping rate insufficient	2
Pumping rate excessive	3
Pumping pressure insufficient	4
Pumping pressure excessive	5
Pump running roughly	6
Pump leaks	7
Excessive motor power uptake	8

Tab. 5 Fault/number assignment

Fault number								Cause	Remedy
1	2	3	4	5	6	7	8		
X	-	-	-	-	-	-	-	Pressure pipe closed by fitting	► Open the fitting.
X	X	-	X	-	X	-	-	Pump or suction strainer blocked or encrusted	► Clean intake/suction pipe, pump or suction strainer.
X	-	-	-	-	-	-	-	Transport and sealing cover still in place	► Remove the transport and sealing cover.
-	X	-	X	-	X	-	-	Back pressure of the system is too high, pump selected is too small.	► Consult the manufacturer.
-	X	-	X	-	X	-	-	Suction head too large: $NPSH_{pump}$ is larger than $NPSH_{system}$	► Increase pump inlet pressure. ► Consult the manufacturer.
X	-	-	-	-	X	-	-	Intake/suction pipe and pump not correctly vented or not completely filled	► Completely fill and vent pump and/or pipe.
X	X	-	X	-	X	-	-	Air is sucked in	► Check the filling level of the container.
X	X	-	X	-	X	-	-	Proportion of gas too high: pump is cavitating	► Consult the manufacturer.
-	X	-	X	-	X	-	-	Temperature of fluid is too high: pump is cavitating	► Increase pump inlet pressure. ► Lower temperature. ► Contact the manufacturer.
-	X	-	X	-	-	-	X	Viscosity or specific gravity of the pumped liquid outside the range specified for the pump	► Consult the manufacturer.
X	X	-	X	-	-	-	-	Geodetic differential head and/or pipe flow resistances too high	► Remove sediments from the pump and/or pressure pipe. ► Install a larger impeller and consult the manufacturer.
-	X	-	-	X	X	-	-	Pressure-side fitting not opened wide enough	► Open the pressure-side fitting.
X	X	-	-	X	X	-	-	Pressure pipe blocked	► Clean the pressure pipe.

Fault number								Cause	Remedy
1	2	3	4	5	6	7	8		
X	X	-	X	-	X	-	-	Pump running in the wrong direction	<ul style="list-style-type: none"> ▶ Check sense of rotation and correct it if necessary (→ 5.6.3 Check direction of rotation, Page 15).
X	X	-	X	-	-	-	-	Motor speed too low	<ul style="list-style-type: none"> ▶ Compare the required motor speed with the specifications on the pump type plate. Replace the motor if necessary. ▶ Increase the motor speed if speed control is available.
-	X	-	X	-	X	-	-	Pump parts worn	<ul style="list-style-type: none"> ▶ Replace the worn pump parts.
-	-	X	X	-	X	-	X	Pressure-side fitting opened too wide	<ul style="list-style-type: none"> ▶ Throttle down at the pressure-side fitting. ▶ Machine the impeller down. Consult the manufacturer and adjust the impeller diameter.
-	-	X	-	-	X	-	X	Geodetic differential head, pipe flow resistances and/or other resistances lower than specified	<ul style="list-style-type: none"> ▶ Throttle down the flow rate at the pressure-side fitting. Observe the minimum flow rate. ▶ Machine the impeller down. Consult the manufacturer and adjust the impeller diameter.
-	-	X	-	X	-	-	-	Viscosity lower than expected	<ul style="list-style-type: none"> ▶ Machine the impeller down. Consult the manufacturer and adjust the impeller diameter.
-	-	X	-	X	X	-	X	Motor speed too high	<ul style="list-style-type: none"> ▶ Compare the required motor speed with the specifications on the pump type plate. Replace the motor if necessary. ▶ Reduce the motor speed if speed control is available.
-	-	X	-	X	X	-	X	Impeller diameter too large	<ul style="list-style-type: none"> ▶ Throttle down the flow rate at the pressure-side fitting. Observe the minimum flow rate. ▶ Machine the impeller down. Consult the manufacturer and adjust the impeller diameter.
X	X	-	X	-	X	-	-	Impeller out of balance or blocked	<ul style="list-style-type: none"> ▶ Clean the impeller.
-	X	-	X	-	X	-	-	Hydraulic parts of the pump dirty, clotted or encrusted	<ul style="list-style-type: none"> ▶ Dismount the pump. ▶ Clean the parts.
-	-	-	-	-	X	-	X	Defective antifriction bearing in motor	<ul style="list-style-type: none"> ▶ Replace the antifriction bearing (→ manufacturer's specifications).
-	-	-	-	-	-	X	-	Connecting bolts not correctly tightened	<ul style="list-style-type: none"> ▶ Tighten the connecting bolts.
-	-	-	-	-	-	X	-	Faulty housing seal	<ul style="list-style-type: none"> ▶ Replace the housing seal
-	-	-	-	-	X	X	X	Pump distorted	<ul style="list-style-type: none"> ▶ Check the pipe connections and pump attachment.
-	X	-	X	-	X	-	X	Motor running on 2 phases	<ul style="list-style-type: none"> ▶ Check the fuse and replace it if necessary. ▶ Check the cable connections and insulation.

Tab. 6 Troubleshooting list

9 Appendix

9.1 Replacement parts

9.1.1 Part numbers and designations

Part no.	Designation
161.01 ¹⁾	Housing cover
230.01	Impeller
260.01	Impeller cap
412.01	O-ring (sealing washer)
412.02	O-ring (shaft sleeve)
412.03	O-ring (impeller cap)
412.04	O-ring (connection)
412.05	O-ring (sealing washer)
444.01	Sealing washer
444.02	Sealing washer
490.01	Sealing flange
490.02	Wafer type flange
507.01	Splash ring (shaft sleeve)
509.01	Intermediate ring (sealing washer)
523.01	Shaft sleeve
531.01	Spring dowel sleeve (shaft sleeve)
550.01	Impeller washer
554.01	Washer (motor attachment)
554.02	Washer (flange attachment)
554.03	Washer (sealing washer)
558.01	Centrifugal disk (shaft sleeve)
713.01	Suspension pipe
730.01	Pipe connector (insert)
731.01	Pipe joint (gland nut)
801.01	Flange motor
901.01	Hexagonal screw (flange attachment)
902.01	Stud screw (motor attachment)
914.01	Hexagon socket-head screw (cylinder screw) (impeller)
914.02	Hexagon socket-head screw (cylinder screw) (motor attachment)
914.03	Hexagon socket-head screw (cylinder screw) (sealing washer)
914.04	Hexagon socket-head screw (cylinder screw) (intermediate flange)
920.01	Nut (motor attachment)

Part no.	Designation
920.02	Nut (impeller)
934.01	Circlip (impeller)
940.01	Fitted key (impeller)

Tab. 7 Designation of components according to part numbers

1) Not suitable for suction strainer or suction extension

9.1.2 Sectional drawings

Size 15-60

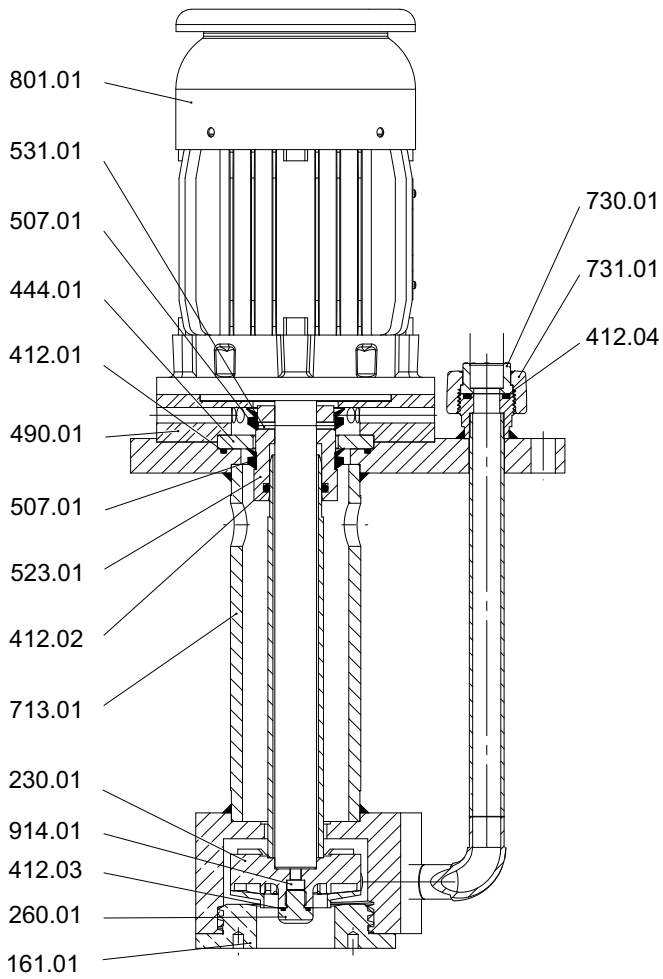

Fig. 7 Sectional view 1

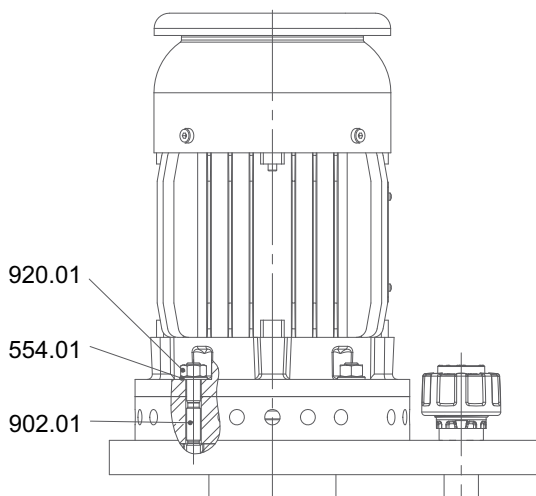

Fig. 8 Sectional view 2

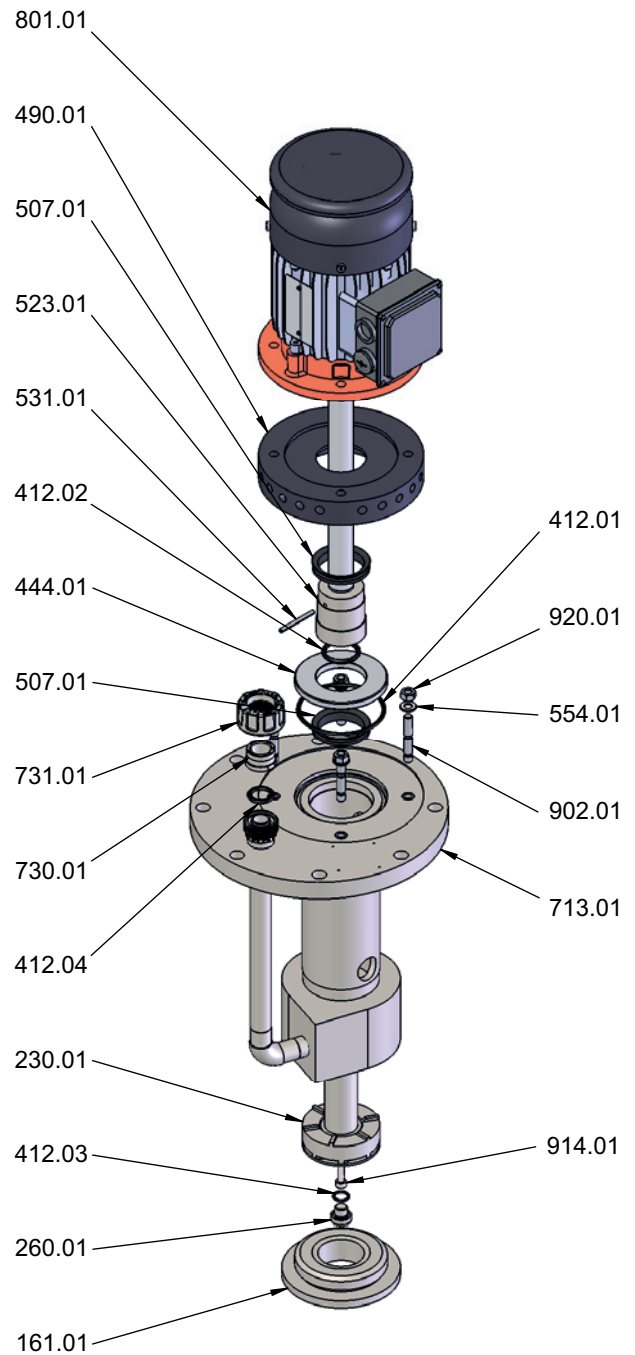

Fig. 9 Exploded drawing

Sizes 20-100; 25-125S; 25-125L

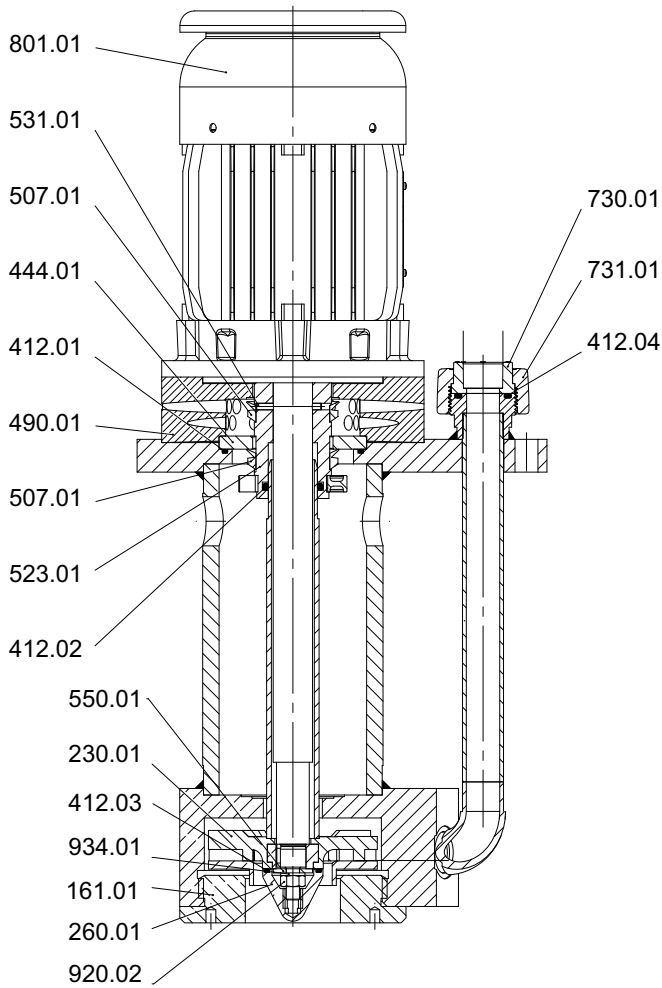

Fig. 10 Sectional view 1

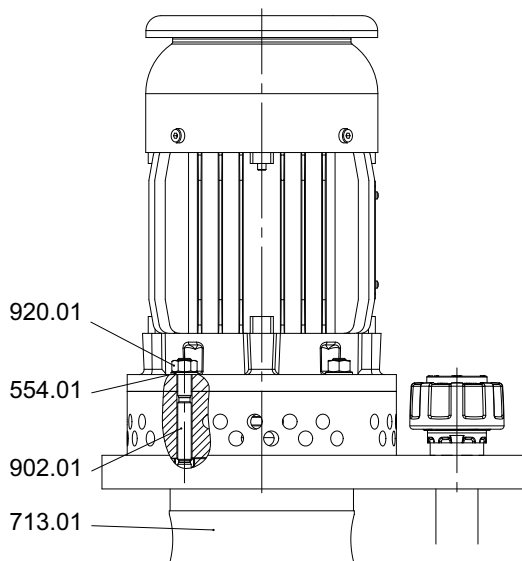

Fig. 11 Sectional view 2

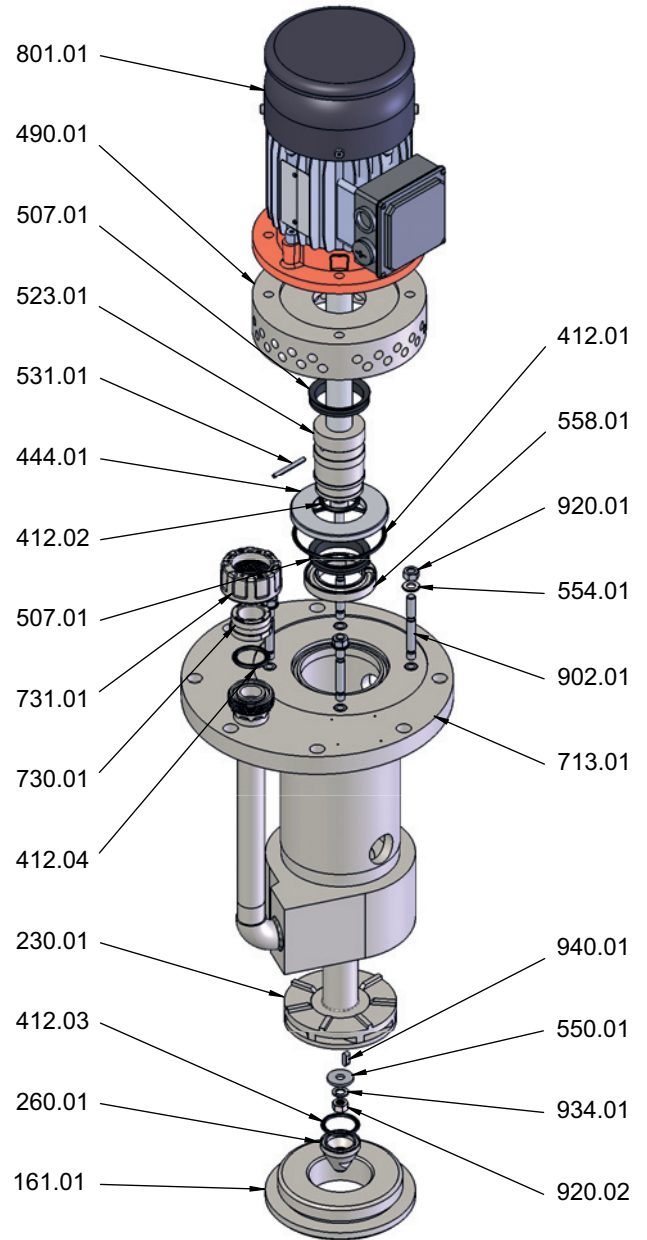

Fig. 12 Exploded drawing

Sizes 32-125; 40-125

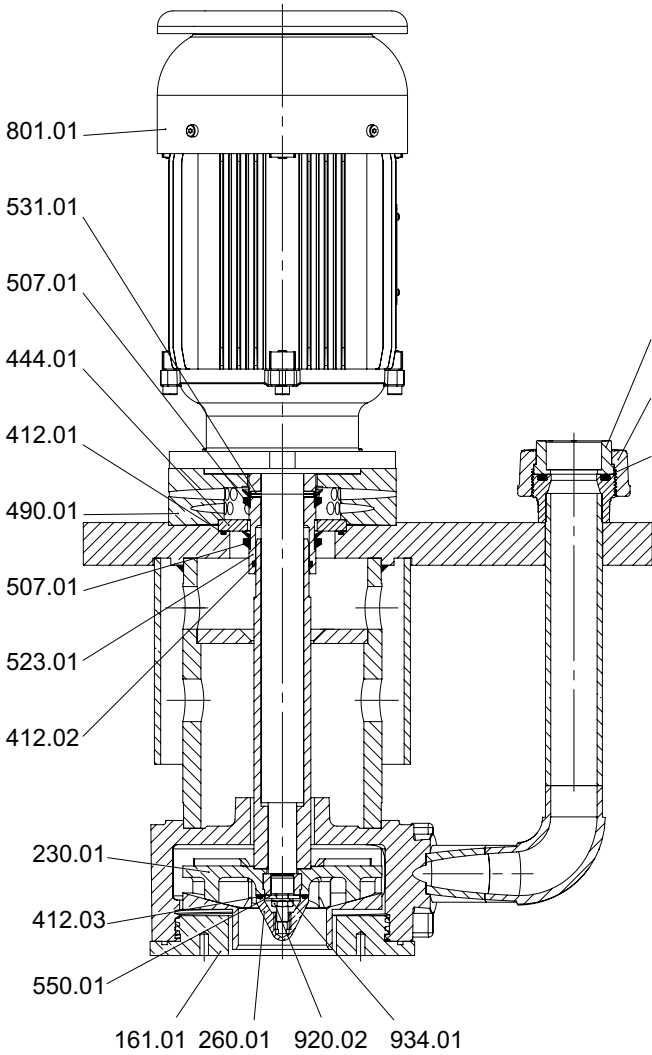

Fig. 13 Sectional view 1

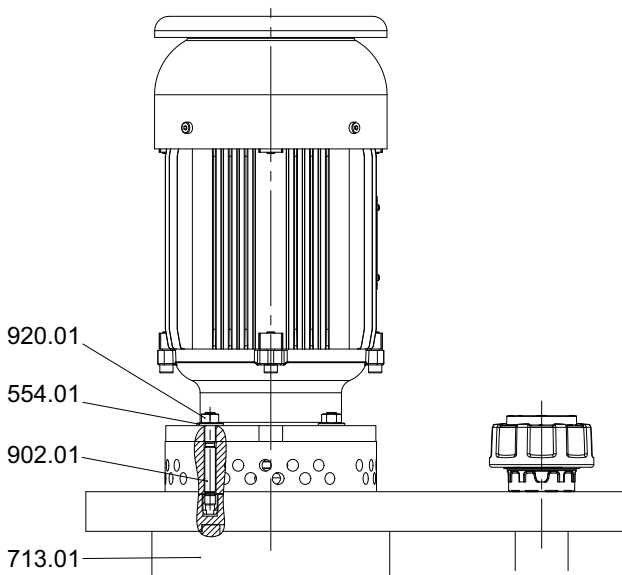

Fig. 14 Sectional view 2

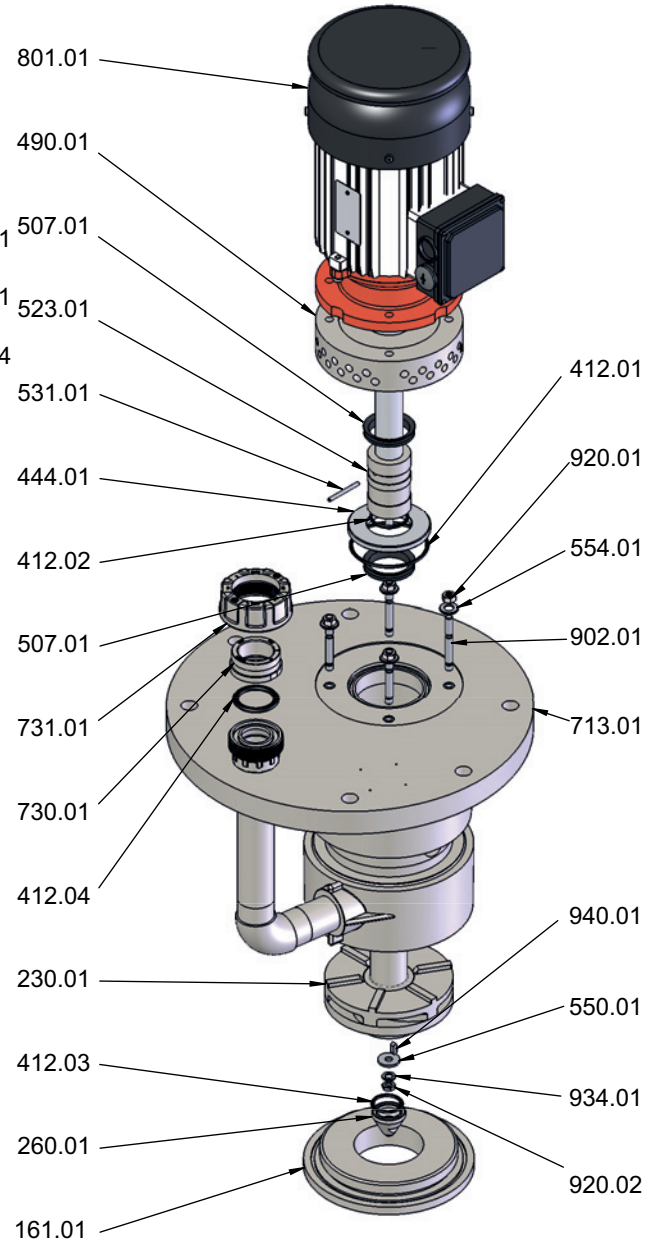

Fig. 15 Exploded drawing

Sizes 32-160 4kW; 40-160 4kW; 50-125 4kW

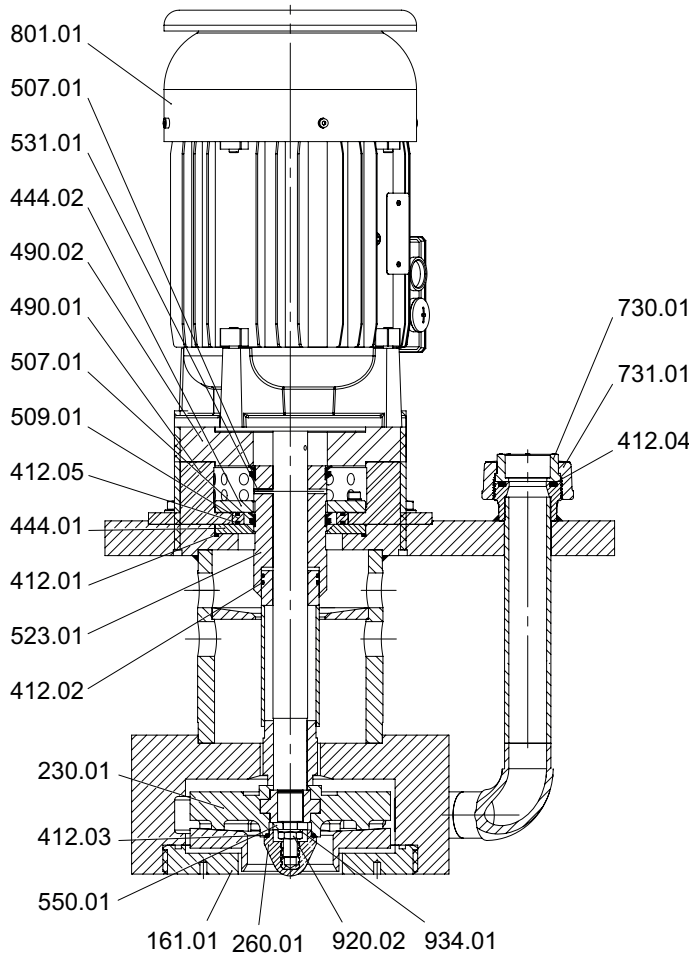

Fig. 16 Sectional view 1

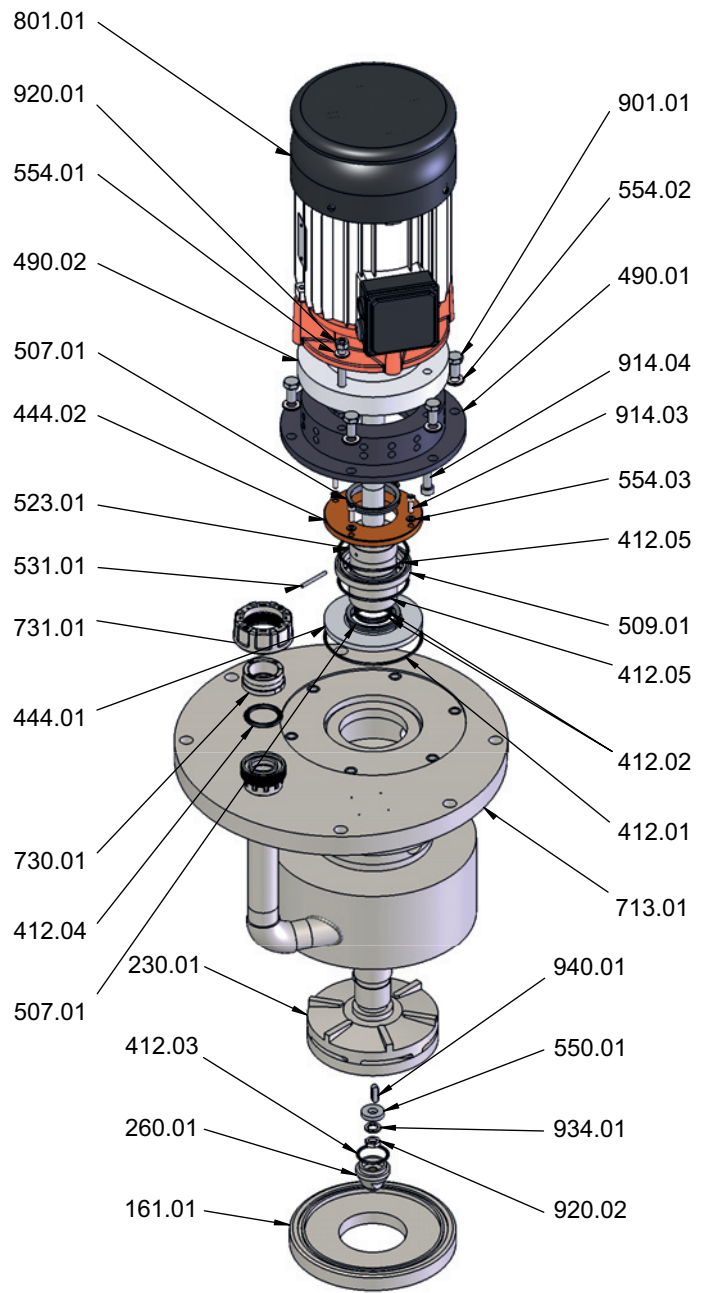

Fig. 18 Exploded drawing

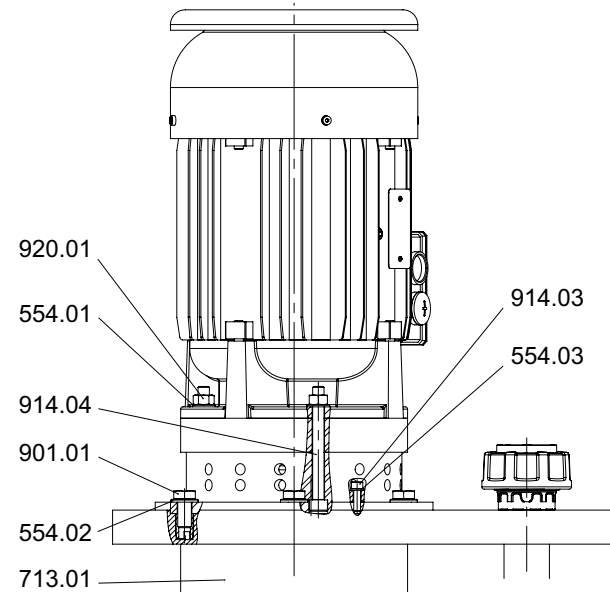

Fig. 17 Sectional view 2

Sizes 32-160 5.5 / 7.7 kW; 40-160 5.5 / 7.7 kW;
50-125 5.5 / 7.7 kW; 80-200

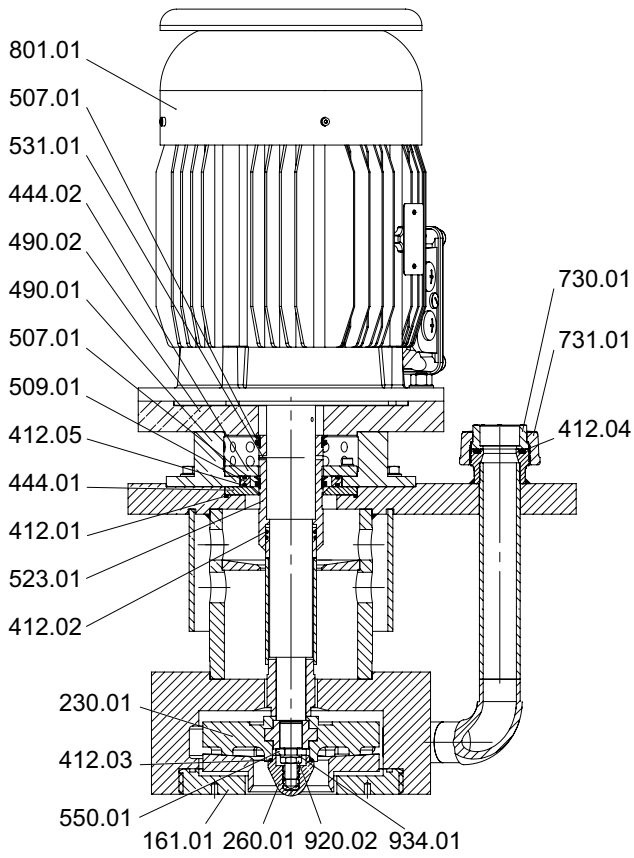

Fig. 19 Sectional view 1

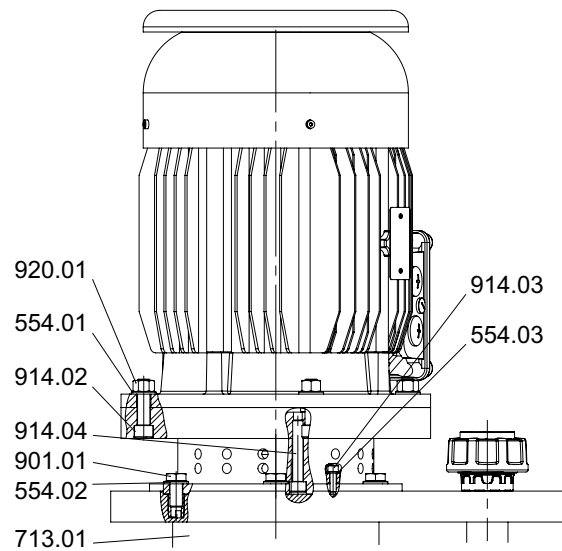

Fig. 20 Sectional view 2

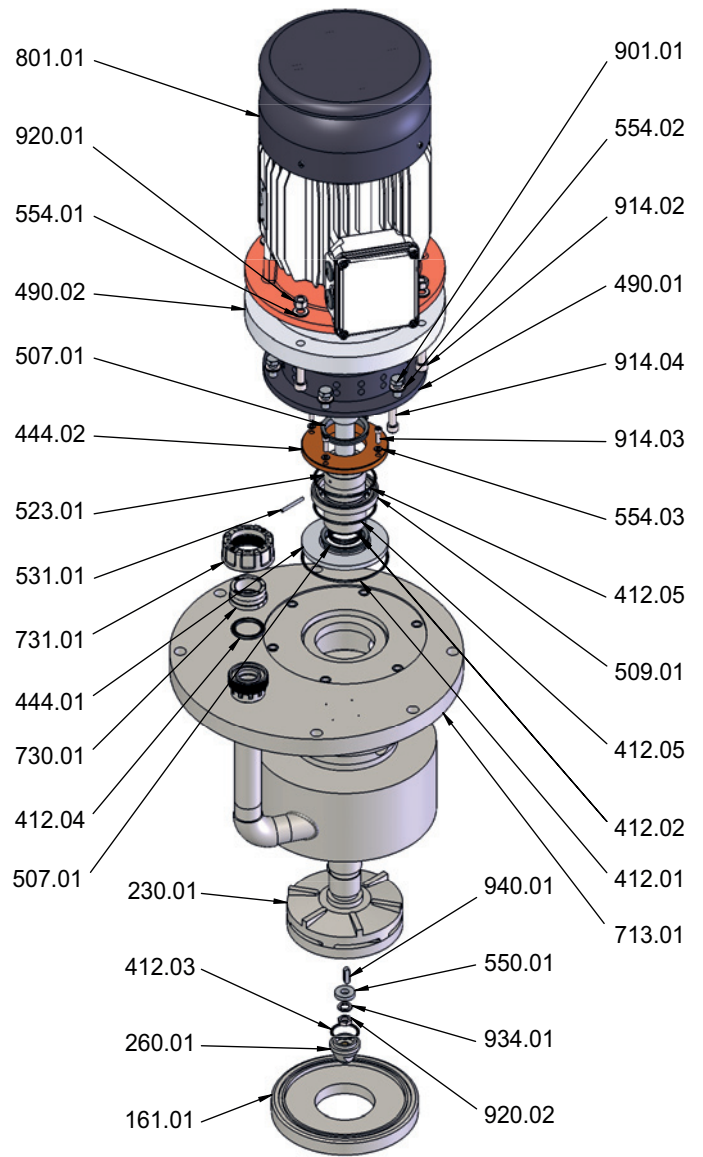

Fig. 21 Exploded drawing

9.2 Technical specifications

Further technical data (→ data sheet).

9.2.1 Ambient conditions

Operation under any other ambient conditions should be agreed with the manufacturer.

Temperature [°C]	Relative humidity [%]		Installation height above sea level [m]
	Long-term	Short-term	
-20 to +40 ¹⁾	≤ 85	≤ 100	≤ 1000

Tab. 8 Ambient conditions

1) material-dependent

9.2.2 Sole plate tightening torques

Screw	Md [Nm]	Screw	Md [Nm]
M8	7	M16	63
M10	14	M20	113
M12	24	M24	193

Tab. 9 Sole plate tightening torques

9.2.3 Tightening torques of casing screws

Apply graphite paste to metallic connections prior to assembly.

Size	Metal / metal ¹⁾	Metal / plastic ²⁾	Metal in metal inserts / plastic ³⁾
M6	9	6	5
M8	21	7	6
M10	42	14	10
M12	73	24	25
M16	170	63	30
M20	340	113	32
M24	580	193	34

Tab. 10 Tightening torques of casing screws

- 1) Metal: Screws, nuts, housing, pipes
- 2) Metal: screws, nuts / Plastic: housing, pipes
- 3) Metal: screws in metal inserts / Plastic: housing with screwed in or encapsulated metal inserts

9.2.4 Filling heights and installation dimensions

Filling heights and installation dimensions (→ data sheet).

9.2.5 Flange tightening torques

d [mm]	ND [mm]	Tightening torque ^{*1)} MD [Nm] for the variants		
		Flat sealing ring max. 10 bar max. 40 °C	Profile seal max. 16 bar	O-ring max. 16 bar
20	15	10	10	10
25	20	12	12	12
32	25	15	12	12
40	32	20	15	15
50	40	25	15	15
63	50	30	20	20
75	65	35	20	20
90	80	35	20	20

Tab. 11 Tightening torques

1) Use a torque wrench

9.2.6 Permissible forces at the pressure socket

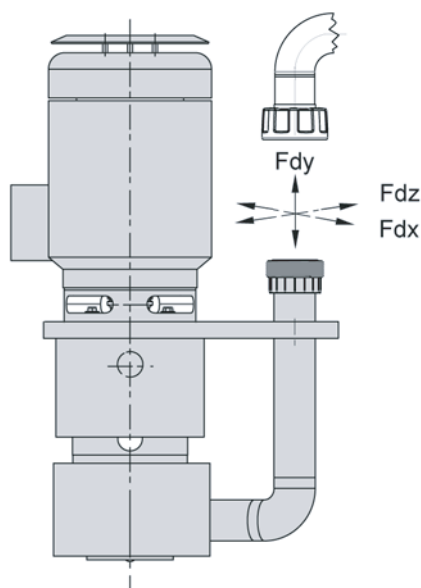

Fig. 22 Permissible forces at the pressure socket

$$\begin{aligned} \Sigma F_x &= 0 \\ \Sigma F_y &= 0 \\ \Sigma F_z &= 0 \end{aligned}$$

9.2.7 Sound pressure level

Maximum noise level LpA for 2-terminal 50Hz/60Hz motors, in dB(A)

Motor power rating	0.37 kW		0.55 kW		0.75 kW		1.10 kW		1.50 kW		2.20 kW		3.00 kW		4.00 kW		5.50 kW		7.50 kW	
	50 Hz	60 Hz	50 Hz	60 Hz	50 Hz	60 Hz	50 Hz	60 Hz	50 Hz	60 Hz	50 Hz	60 Hz	50 Hz	60 Hz	50 Hz	60 Hz	50 Hz	60 Hz	50 Hz	60 Hz
ETLB-S 15–60	59	61	59	61	61	63														
ETLB-S 20–100	59	61	59	61	61	63														
ETLB-S 125–125S	59	61	59	61	61	63	61	63	65	67	65	67								
ETLB-S 125–125L					61	63	61	63	65	67	65	67								
ETLB-S 32–125									65	67	65	67	68	70	70	72	70	72		
ETLB-S 32–160														70	72	70	72	70		
ETLB-S 40–125									65		65	67	68	70	70	72	70	72	70	
ETLB-S 40–160														70		70	72	70		
ETLB-S 50–125														70		70	72	70		
ETLB-S 80–200 ¹⁾																66	68	66		

Tab. 12 Noise level LpA to DIN EN ISO 11203

1) 4-wire

Measuring conditions:

- Distance to the pump: 1 m
- Operation: free of cavitation
- Motor: IEC standard motor
- Tolerance ±3 dB

9.3 Maintenance schedule

Designation	Interval	Maintenance
Operating temperatures	weekly	<ul style="list-style-type: none"> ▶ Check storage temperature. ▶ Check motor temperature.
Undoable screwed connections	weekly	<ul style="list-style-type: none"> ▶ Check for correct and tight fitting.
Impeller	as required	<ul style="list-style-type: none"> ▶ Check impeller for wear and damage. ▶ Clean or replace the impeller.

Tab. 13 Maintenance schedule

9.4 Declaration of conformity in accordance with EC machinery directive

EU Declaration of Conformity



ASV-Stübbe GmbH & Co. KG, Hollwieser Straße 5, 32602 Vlotho, Germany, declares on its own authority that the following products

Description

Centrifugal pumps with mechanical seal

NM, NMB, NMXH, NX, SHB

Magnetically-coupled pumps

SHM

Eccentric pumps

Type F, Type L

Sump pumps

ET, ETL, ETLB, ETLB-S, ETLB-T, ETLB-ST

to which this declaration relates, are in conformity with the following standards:

Machinery Directive 2006/42/EC

EMC Directive 2014/30/EU

With regard to electrical hazards the protective aims of Low Voltage Directive 2014/35/EU have been complied with under Appendix I no. 1.5.1 of Machinery Directive 2006/42/EU.

Place and date

Vlotho, 21.12.2017

Name and signature of authorized person

pp Achim Kaesberg,
Head of Electrical Engineering