

# Pressure relief valve

Operating manual

Series DHV 712



---

Version BA-2015.10.20 EN  
Print-No. 300 510  
TR MA DE Rev001

ASV Stübbe GmbH & Co. KG  
Hollwieser Straße 5  
32602 Vlotho  
Germany  
Phone: +49 (0) 5733-799-0  
Fax: +49 (0) 5733-799-5000  
E-mail: [contact@asv-stuebbe.de](mailto:contact@asv-stuebbe.de)  
Internet: [www.asv-stuebbe.com](http://www.asv-stuebbe.com)



We reserve the right to make technical changes.  
Read carefully before use.  
Save for future use.

# 1 About this document

This manual

- is part of the fitting
- applies to all series referred to
- describes safe and proper operation during all operating phases

## 1.1 Target groups



### Operating company

- Responsibilities:
  - Keep this manual available at the place of operation, also for future use.
  - Ensure that employees read and observe this manual and other applicable documents, especially the safety instructions and warnings.
  - Observe any additional country-specific rules and regulations that relate to the system.

### Qualified personnel, fitter







- Mechanics qualification:
  - Qualified employees with additional training for fitting the respective pipework.
- Electrical qualification:
  - Qualified electrician
- Responsibility:
  - Read, observe and follow this manual and the other applicable documents, especially all safety instructions and warnings.

## 1.2 Other applicable documents

Document/purpose/location	QR code
Resistance lists <ul style="list-style-type: none"> <li>• Resistance of materials used to chemicals</li> <li>• <a href="http://www.asv-stuebbe.de/pdf_resistance/300051.pdf">www.asv-stuebbe.de/pdf_resistance/300051.pdf</a></li> </ul>	
Data sheet <ul style="list-style-type: none"> <li>• Technical specifications, conditions of operation</li> <li>• <a href="http://www.asv-stuebbe.de/pdf_datasheets/300516.pdf">www.asv-stuebbe.de/pdf_datasheets/300516.pdf</a></li> </ul>	
CE declaration of conformity <ul style="list-style-type: none"> <li>• Conformity with standards</li> <li>• <a href="http://www.asv-stuebbe.de/pdf_DOC/300168.pdf">www.asv-stuebbe.de/pdf_DOC/300168.pdf</a></li> </ul>	

Tab. 1 Other application documents, purpose and where found

## 1.3 Warnings and symbols

Symbol	Meaning
	<ul style="list-style-type: none"> <li>• Immediate acute risk</li> <li>• Death, serious bodily harm</li> </ul>
	<ul style="list-style-type: none"> <li>• Potentially acute risk</li> <li>• Death, serious bodily harm</li> </ul>
	<ul style="list-style-type: none"> <li>• Potentially hazardous situation</li> <li>• Minor injury</li> </ul>
	<ul style="list-style-type: none"> <li>• Potentially hazardous situation</li> <li>• Material damage</li> </ul>
	Safety warning sign ► Take note of all information highlighted by the safety warning sign and follow the instructions to avoid injury or death.
►	Instruction
1. , 2. , ...	Multiple-step instructions
✓	Precondition
→	Cross reference
	Information, notes

Tab. 2 Warnings and symbols

## 2 Safety

 The manufacturer accepts no liability for damages caused by disregarding any of the documentation.

### 2.1 Intended use

- Exclusively use the fitting as pressure-relief or overflow valve in pipes for appropriate media (→ Resistance list).
- Adhere to the operating limits (→ 9.1.1 Pressure and temperature limits, Page 10).
- Use fitting for solids-free media.

### 2.2 General safety instructions

 Observe the following regulations before carrying out any work.

#### 2.2.1 Obligations of the operating company

##### Safety-conscious operation

- Only operate the fitting if it is in perfect technical condition and only use it as intended, staying aware of safety and risks, and in adherence to the instructions in this manual.
- Ensure that the following safety aspects are observed and monitored:
  - Intended use
  - Statutory or other safety and accident-prevention regulations
  - Safety regulations governing the handling of hazardous substances
  - Applicable standards and guidelines in the country where the pump is operated
- Make personal protective equipment available.

##### Qualified personnel

- Make sure all personnel tasked with work on the fitting have read and understood this manual and all other applicable documents, especially the safety, maintenance and repair information, before they start any work.
- Organize responsibilities, areas of competence and the supervision of personnel.
- The following work should be carried out by specialist technicians only:
  - Installation, repair and maintenance work
  - Work on the electrical system
- Make sure that trainee personnel only work on the fitting under supervision of specialist technicians.

#### 2.2.2 Obligations of personnel

- Observe the instructions on the fitting and keep them legible, e.g. nameplate, identification marking for fluid connections.
- Only carry out work on the fitting if the following requirements are met:
  - System is empty
  - System has been flushed
  - System is depressurized
  - System has cooled down
  - System is secured against being switched back on again

### 2.3 Specific hazards

#### 2.3.1 Hazardous media

- When handling hazardous media (e.g. hot, flammable, explosive, toxic, hazardous to health or the environment), observe the safety regulations for the handling of hazardous substances.
- Use personal protective equipment when carrying out any work on the fitting.
- Collect leaking pumped liquid and residues in a safe manner and dispose of in accordance with environmental regulations.

## 3 Layout and Function

### 3.1 Marking

#### 3.1.1 Name plate

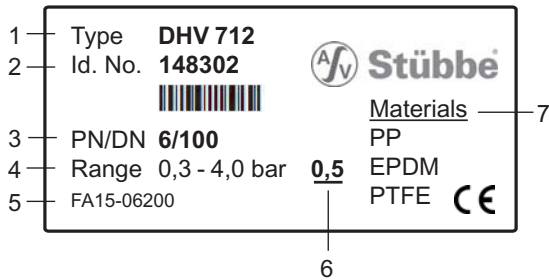

Fig. 1 Nameplate (example)

- 1 Type
- 2 ID number
- 3 Nominal pressure [bar] / Nominal diameter [mm]
- 4 Pressure range
- 5 Serial number – production date
- 6 Pressure presetting
- 7 Materials (body, ball seals, other gaskets)

### 3.2 Layout

The fitting is a pressure relief valve controlled by medium. It is used to keep preset operating pressures constant.

The fitting can also be used as an overflow valve to prevent pressure peaks.

- Direction of flow in direction of arrow (→ 3.3 Direction of flow, Page 5).
- Optional installation position
- Fastening via threaded inserts (metal inserts) in the valve body

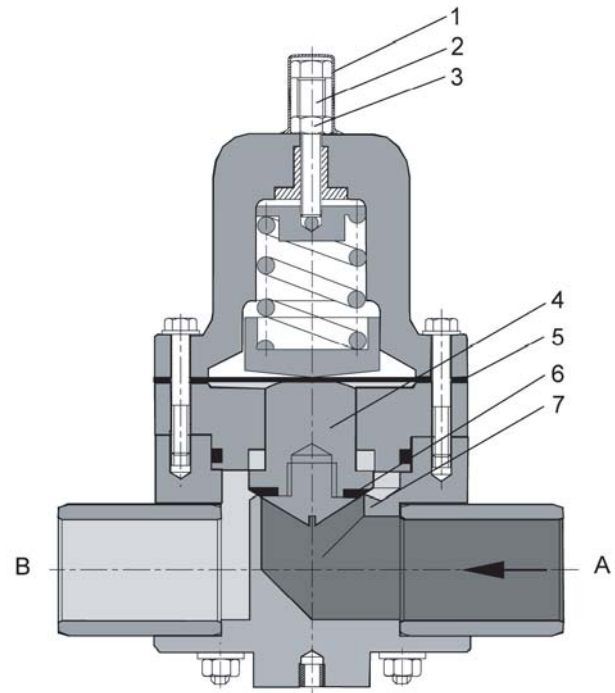

Fig. 2 Layout

- A Primary side
- B Secondary side
- 1 Protection cap
- 2 Adjustment screw
- 3 Counter nut
- 4 Piston
- 5 Membrane
- 6 Flat sealing ring
- 7 Valve seat

### 3.3 Direction of flow

 The direction of flow can be identified by the arrow on the fitting.



Fig. 3 Fitting with directional arrow

1 Directional arrow

## 4 Transport, Storage and Disposal

### 4.1 Unpacking and inspection on delivery

1. Unpack the fitting when received and inspect it for transport damage.
2. Report any transport damage to the manufacturer immediately.
3. Ensure that the information on the type plate agrees with the order/design data.
4. For immediate installation, dispose of packaging material according to local regulations.
  - For later installation, leave the fitting in the original packaging.

### 4.2 Transportation

1. If possible, transport fitting (including drive) in original packaging.
2. To transport, lift the fitting by hand, weight specifications (→ Data sheet)

### 4.3 Storage

---

#### NOTE

---

##### Material damage due to inappropriate storage!

- ▶ Store the fitting properly.
- 
- ▶ Make sure the storage room meets the following conditions:
    - Dry
    - Frost-free
    - Vibration-free
    - Not in direct sunlight
    - Storage temperature +10 °C to +60 °C

## 4.4 Disposal

 Plastic parts can be contaminated by poisonous or radioactive media to such an extent that cleaning will not be sufficient.

### WARNING

#### Risk of poisoning and environmental damage from medium.

- ▶ Use personal protective equipment when carrying out any work on the fitting.
  - ▶ Before disposing of the fitting:
    - Collect leaking medium and dispose separately according to local regulations.
    - Neutralize residues of medium in the fitting.
  - ▶ Remove plastic parts and dispose of them in accordance with local regulations.
- 
- ▶ Dispose of fitting in accordance with local regulations.

## 5 Installation and connection

### 5.1 Preparing for installation

#### 5.1.1 Check operating conditions

1. Ensure the design of the fitting is consistent with the purpose intended:
  - Materials used (→ nameplate).
  - Medium (→ order and design data).
2. Ensure the required operating conditions are met:
  - Resistance of body and seal material to the medium (→ resistance lists).
  - Media temperature (→ 9.1.1 Pressure and temperature limits, Page 10).
  - Working pressure (→ 9.1.1 Pressure and temperature limits, Page 10).
3. Consult with the manufacturer regarding any other use of the device.

### 5.2 Planning pipelines

#### 5.2.1 Designing pipelines

### WARNING

#### Risk of poisoning and environmental damage from medium.

Leaks due to impermissible pipework forces.

- ▶ Ensure that the fitting is not subject to any pulling or thrusting forces or bending moments.

1. Plan pipes safely:
  - No pulling or thrusting forces
  - No bending moments
  - Adjust for changes in length due to temperature changes (compensators, expansion shanks)
  - Optional installation position
2. Dimensions (→ Data sheet).

## 5.3 Installing fitting in pipe

### ⚠ WARNING

**Risk of poisoning and environmental damage from medium.**

Leak due to faulty installation.

- ▶ Installation work on the pipes should only be performed by technicians who have been specially trained for the pipework in question.

### NOTE

**Material damage due to contamination of the fitting!**

- ▶ Make sure no contamination reaches the fitting.
- ▶ Flush the pipe with a neutral medium.

**i** The fitting is installed according to the connection type of the pipes.

**i** For connection with solvent welding/fusion spigot ends: Use suitable solvent welding/fusion socket ends.

**i** Observe direction of flow (→ 3.3 Direction of flow, Page 5).

### 5.3.1 Connection with solvent welding/fusion spigot ends

1. Prepare pipe ends according to connection type.
2. Adhesively apply or weld fitting with solvent welding/fusion socket ends (→ Manufacturer information).

### 5.3.2 Connection with flange

1. Prepare pipe ends according to connection type.
2. Radially push the fitting between the flange ends.
3. Bolt fitting and flange with flange screws, nuts and washers.  
While doing so, observe tightening torques: (→ 9.1.3 Tightening torques, Page 11).

## 5.4 Performing the hydrostatic test

**i** Perform hydrostatic test using neutral medium, e.g. water.

1. Pressurize the fitting, Ensure that:
  - Test pressure < 1.5 P<sub>N</sub>
  - Test pressure < P<sub>N</sub> + 5 bar
  - Test pressure < permissible system pressure
2. Check the fitting for leaks.

## 6 Operation

### 6.1 Set pressure

**i** Presetting from factory: 0.5 bar (→ nameplate). Other pre-setting possible upon consultation with manufacturer.

Set the pressure relief valve under the same conditions encountered later during operation!

Recommendation for the setting: Installation of a diaphragm pressure gauge guard before the pressure relief valve.

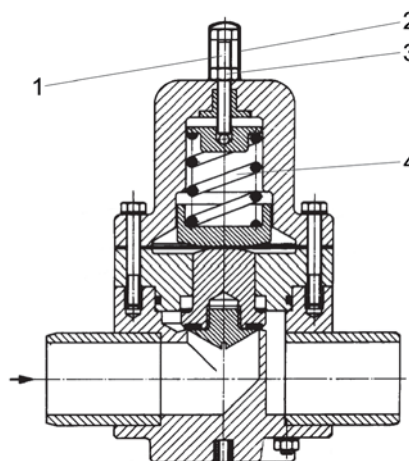

Fig. 4 Set pressure

- 1 Adjustment screw
- 2 Protection cap
- 3 Counter nut
- 4 Pressure spring

1. Remove protection cap (2) at adjustment screw from the valve.
2. Undo locknut (3).
3. Turn adjustment screw (1) counter-clockwise until the pressure spring (4) is completely relieved of tension.

Valve is open.

4. Start up system.
5. Turn adjustment screw (1) clockwise until desired system pressure is reached.
6. Fix the adjustment screw (1) using a ring wrench, then tighten the locknut (3).

**i** Adjustment screw can be sealed to prevent unauthorized adjustment, if necessary.

7. Plug on protection cap (2).

## 6.2 Commissioning

- ✓ Fitting correctly installed and connected

### WARNING

#### Risk of injury and poisoning due to medium spraying out.

- ▶ Use personal protective equipment when carrying out any work on the fitting.
- 
- ▶ After the initial stresses due to pressure and operating temperature, check if the fitting is sealed.

## 7 Maintenance

### WARNING

#### Risk of injury and poisoning due to hazardous media liquids!

- ▶ Use personal protective equipment when carrying out any work on the fitting.

### 7.1 Servicing

1. Visual and function check (every three months):
  - Normal operating conditions unchanged
  - No leaks
  - No unusual operating noises or vibrations
2. Check tightening torque of screws (12/15) (→ 9.1.3 Tightening torques, Page 11).
3. Clean fitting with a moist cloth if necessary.

### 7.2 Maintenance

### WARNING

#### Risk of injury and poisoning due to hazardous or hot media.

- ▶ Use personal protective equipment when carrying out any work on the fitting.
- ▶ Safely collect the media and dispose of it in accordance with environmental regulations.

### WARNING

#### Risk of injury during disassembly!

- ▶ Wear protective gloves, components can be very sharp-edged due to wear or damage.
- ▶ Remove components with springs (e.g. pneumatic drive) carefully, since spring tension can cause components to be ejected.

#### 7.2.1 Removing fitting

1. Ensure that:
  - System is empty
  - System has been flushed
  - System is depressurized
  - System has cooled down
  - System is secured against being switched back on again
2. Remove fitting from the pipe.
3. Decontaminate fitting if required.
  - Dead space in the fitting may still contain medium.



### 7.2.2 Renew diaphragms and seals

 Drawing (→ 9.1.2 Drawing, Page 11).

1. Remove protective cap (9).
2. Undo locknut (14).
3. Mark screw depth at adjustment screw (13).
4. Unscrew adjustment screw (13) until pressure spring (8) is relieved of tension.
5. Remove protective caps (18).
6. Unscrew hex screws (12) and remove washers (16).
7. Loosen hex nuts (17) and remove washers (16).
8. Remove upper part (2) upward.
9. Remove pressure plate (6), steel ball (7), pressure spring (8) and spring plate (5).
10. Remove diaphragm (10).  
This disengages the threaded rod (15).
11. Remove threaded rod (15).
12. Remove separating disc (3).
13. Remove piston (4).
14. Check housing (1) in interior (seal seat) for damage.  
If case of damage, replace housing (1).
15. Check piston (4) on sliding surface for damage.  
Replace if necessary.
16. Undo piston tip (20).
17. Replace flat sealing ring (19).
18. Tighten piston tip (20).
19. Check separating disc (3) at piston sliding surfaces:  
Piston (4) must move easily back and forth.  
Replace separating disc (3) if necessary.
20. Check O-ring (11) for damage.  
Replace if necessary.
21. Set piston (4) centered onto seal seat in housing (1).
22. Set separating disc (3) into housing (1) above piston (4).  
Position screw holes above each other.
23. Insert diaphragm (10).  
Position screw holes above each other.
24. Push threaded rods (15) through from below.
25. Set spring plate (5) with pressure plate (6), steel ball (7) and pressure spring (8) centered onto diaphragm (10).
26. Set upper part (2) onto fitting.
27. Tighten hex screws (12) and washers (16) on fitting with 20 Nm (→ 9.1.3 Tightening torques, Page 11).
28. Tighten hex nuts (17) and washers (16) on fitting with 20 Nm (→ 9.1.3 Tightening torques, Page 11).
29. Put on protective caps (18).
30. Screw adjustment screw (13) into fitting up to marked screw depth.
31. Tighten locknut (14).
32. Put on protective cap (9).
33. Check system pressure (→ 5.4 Performing the hydrostatic test, Page 7).

### 7.3 Replacement parts and return

1. For spare part orders or returns  
(→ [www.asv-stuebbe.com/service/downloads](http://www.asv-stuebbe.com/service/downloads)).



2. Have the following information ready to hand when ordering spare parts (→ nameplate).
  - Fitting type
  - ID number
  - Nominal pressure and diameter
  - Body and seal material

## 8 Troubleshooting

### WARNING

**Risk of injury and poisoning due to hazardous or hot media.**

- ▶ Use personal protective equipment when carrying out any work on the fitting.
- ▶ Safely collect the media and dispose of it in accordance with environmental regulations.

Consult with the manufacturer regarding faults which are not identified in the following table, or which cannot be traced to the indicated causes.

Error	Possible cause	Corrective action
Fitting leaky at diaphragm	Insufficient contact pressure (diaphragm fastening)	Retighten screws
Pressure falls below the set value	Valve seat or seat seal leaky	Check piston / seat seal, replace if necessary
	Diaphragms leaky	Renew diaphragms (→ 7.2.2 Renew diaphragms and seals, Page 9).
Pressure rises above permissible value	Fitting installed in backwards	Install fitting in correction direction (→ 3.3 Direction of flow, Page 5).
Medium leaks out at adjustment screw	Diaphragms defective	Renew diaphragms (→ 7.2.2 Renew diaphragms and seals, Page 9).

Tab. 3 Troubleshooting

## 9 Appendix

### 9.1 Technical specifications

Technical data (→ Data sheet).

#### 9.1.1 Pressure and temperature limits

Other media (→ resistance lists).

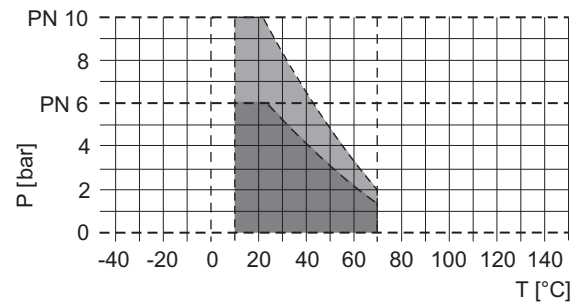

Fig. 5 Pressure and temperature limits PP

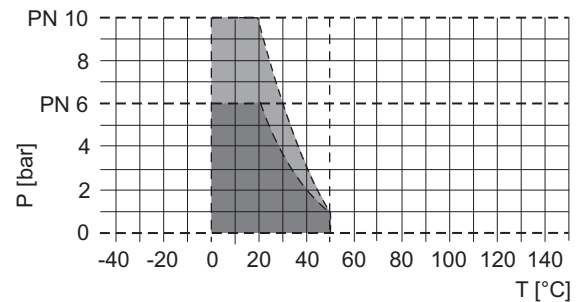

Fig. 6 Pressure and temperature limits PVC-U

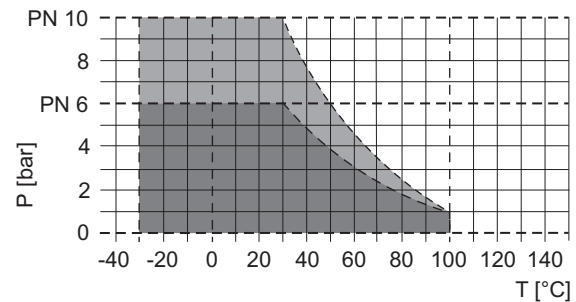
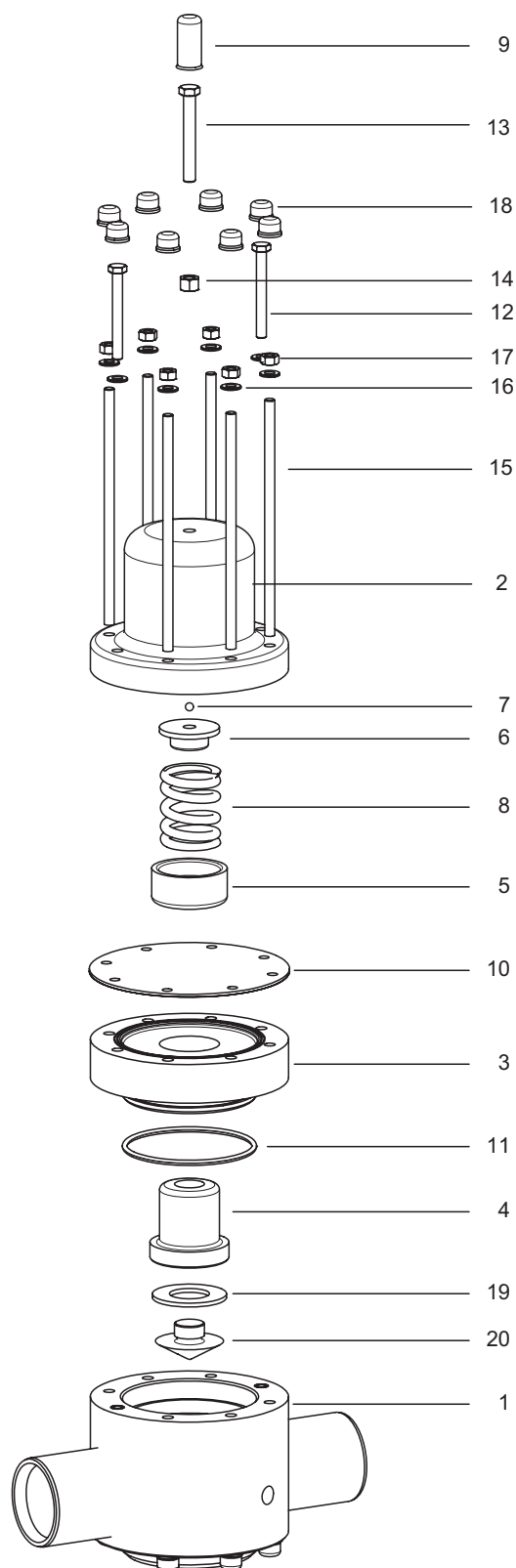

Fig. 7 Pressure and temperature limits PVDF

9.1.2 Drawing



Item	Designation
1	Housing, complete
2	Upper part
3	Separating disc
4	Piston, complete
5	Spring plate
6	Pressure plate
7	Steel ball
8	Pressure spring
9	Protection cap
10	Membrane
11	O-ring
12	hexagon bolt
13	Adjustment screw
14	Counter nut
15	DN 65: Hexagon bolt DN 80 / DN 100: Threaded rod
16	Washer
17	Hexagon nut
18	Protection cap
19	Flat sealing ring
20	Piston tip

Tab. 4 Part designations

9.1.3 Tightening torques

Description	Tightening torque [Nm] for sizes		
	75	90	110
Flange PVC-U	35	40	50
Flange GFR	37	40	50
Flange PP	40	40	50
Housing screws <sup>1)</sup> (hex screws, hex nuts)	20	20	20

Tab. 5 Tightening torques

1) Housing screws greased

Fig. 8 Drawing

