

Pressure reducing valve

Operating manual

Series
DMV 750



Version BA-2016.05.31 EN
Print-No. 300 560
TR MA DE Rev001

ASV Stübbe GmbH & Co. KG
Hollwieser Straße 5
32602 Vlotho
Germany
Phone: +49 (0) 5733-799-0
Fax: +49 (0) 5733-799-5000
E-mail: contact@asv-stuebbe.de
Internet: www.asv-stuebbe.com



We reserve the right to make technical changes.
Read carefully before use.
Save for future use.

1 About this document

This manual

- is part of the fitting
- applies to all series referred to
- describes safe and proper operation during all operating phases

1.1 Target groups

Operating company

- Responsibilities:
 - Keep this manual available at the place of operation, also for future use.
 - Ensure that employees read and observe this manual and other applicable documents, especially the safety instructions and warnings.
 - Observe any additional country-specific rules and regulations that relate to the system.

Qualified personnel, fitter







- Mechanics qualification:
 - Qualified employees with additional training for fitting the respective pipework.
- Electrical qualification:
 - Qualified electrician
- Responsibility:
 - Read, observe and follow this manual and the other applicable documents, especially all safety instructions and warnings.

1.2 Other applicable documents

<p>To download: Resistance guide Chemical resistance of the materials used</p>  <p>http://www.asv-stuebbe.de/pdf_resistance/300051.pdf</p>
 <p>To download: Data sheet DMV750 Technical data, operating conditions</p> <p>http://www.asv-stuebbe.de/pdf_datasheets/300566.pdf</p>
<p>To download: CE declaration of conformity Conformity with standards</p>  <p>http://www.asv-stuebbe.de/pdf_DOC/300168.pdf</p>

Tab. 1 Other application documents, purpose and where found

1.3 Warnings and symbols

Symbol	Meaning
	<ul style="list-style-type: none"> • Immediate acute risk • Death, serious bodily harm
	<ul style="list-style-type: none"> • Potentially acute risk • Death, serious bodily harm
	<ul style="list-style-type: none"> • Potentially hazardous situation • Minor injury
	<ul style="list-style-type: none"> • Potentially hazardous situation • Material damage
	<p>Safety warning sign</p> <ul style="list-style-type: none"> ▶ Take note of all information highlighted by the safety warning sign and follow the instructions to avoid injury or death.
	Instruction
1. , 2. , ...	Multiple-step instructions
✓	Precondition
→	Cross reference
	Information, notes

Tab. 2 Warnings and symbols

2 General safety instructions

 The manufacturer accepts no liability for damages caused by disregarding any of the documentation.

2.1 Intended use

- Exclusively use the fitting as pressure-reducing valve in pipes for appropriate media (→ Resistance list).
- Adhere to the operating limits (→ 9.2.2 Pressure and temperature limits, Page 12).
- Observe setting range (→ 9.2.1 Setting range, Page 12).
- Use fitting for solids-free media.

2.2 General safety instructions

 Read and observe the following regulations before carrying out any work.

2.2.1 Obligations of the operating company

Safety-conscious operation

- Only operate the fitting if it is in perfect technical condition and only use it as intended, staying aware of safety and risks, and in adherence to the instructions in this manual.
- Ensure that the following safety aspects are observed and monitored:
 - Intended use
 - Statutory or other safety and accident-prevention regulations
 - Safety regulations governing the handling of hazardous substances
 - Applicable standards and guidelines in the country where the pump is operated
- Make personal protective equipment available.

Qualified personnel

- Make sure all personnel tasked with work on the fitting have read and understood this manual and all other applicable documents, especially the safety, maintenance and repair information, before they start any work.
- Organize responsibilities, areas of competence and the supervision of personnel.
- The following work should be carried out by specialist technicians only:
 - Installation, repair and maintenance work
 - Work on the electrical system
- Make sure that trainee personnel only work on the fitting under supervision of specialist technicians.

2.2.2 Obligations of personnel

- Observe the instructions on the fitting and keep them legible, e.g. nameplate, identification marking for fluid connections.
- Only carry out work on the fitting if the following requirements are met:
 - System is empty
 - System has been flushed
 - System is depressurized
 - System has cooled down
 - System is secured against being switched back on again
- Do not make any modifications to the device.

2.3 Specific hazards

2.3.1 Hazardous media

- When handling hazardous media (e.g. hot, flammable, explosive, toxic, hazardous to health or the environment), observe the safety regulations for the handling of hazardous substances.
- Use personal protective equipment when carrying out any work on the fitting.
- Collect leaking pumped liquid and residues in a safe manner and dispose of in accordance with environmental regulations.

3 Layout and Function

3.1 Marking

3.1.1 Nameplate

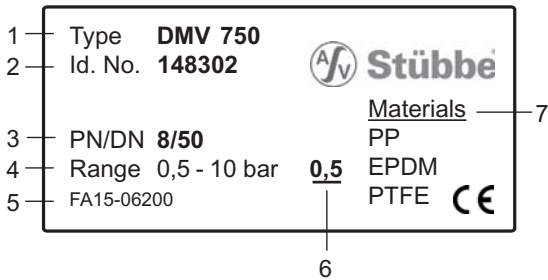

Fig. 1 Nameplate (example)

- 1 Type
- 2 ID number
- 3 Nominal pressure [bar] / Nominal diameter [mm]
- 4 Pressure range
- 5 Serial number – production date
- 6 Pressure presetting
- 7 Materials

3.2 Layout

The fitting is a pressure relief valve controlled by medium. It closes at a defined inlet pressure and is used to reduce primary pressures to operating pressures and for regulated, constant operating pressures.

As a result, the system parts downstream of the fitting are safely protected against excess pressure.

- Optional installation position
- Fastening via threaded inserts (metal inserts) in the valve body

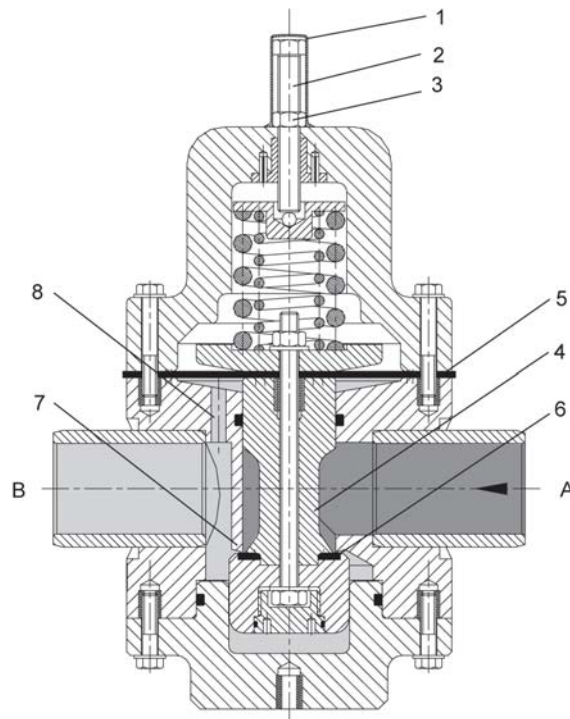

Fig. 2 Design DMV750

- A Primary side
- B Secondary side
- 1 Protection cap
- 2 Adjustment screw
- 3 Counter nut
- 4 Piston
- 5 Membrane
- 6 Flat sealing ring
- 7 Valve seat
- 8 Control bore hole

3.3 Direction of flow

The direction of flow can be identified by the arrow on the fitting.

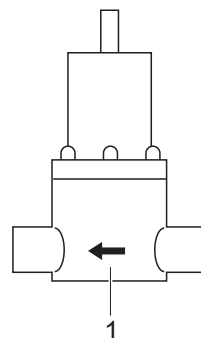

Fig. 3 Fitting with directional arrow (example)

- 1 Directional arrow

4 Transport, Storage and Disposal

4.1 Unpacking and inspection on delivery

1. Unpack the fitting when received and inspect it for transport damage.
2. Report any transport damage to the manufacturer immediately.
3. Ensure that the information on the nameplate agrees with the order/design data.
4. For immediate installation, dispose of packaging material according to local regulations.
 - For later installation, leave the fitting in the original packaging.

4.2 Transportation

1. If possible, transport fitting (including drive) in original packaging.
2. To transport, lift the fitting by hand, weight specifications (→ Data sheet)

4.3 Storage

NOTE

Material damage due to inappropriate storage!

- ▶ Store the fitting properly.
-
- ▶ Make sure the storage room meets the following conditions:
 - Dry
 - Frost-free
 - Vibration-free
 - Not in direct sunlight
 - Storage temperature +10 °C to +60 °C

4.4 Disposal

-  Plastic parts can be contaminated by poisonous or radioactive media to such an extent that cleaning will not be sufficient.

WARNING

Risk of poisoning and environmental damage from medium.

- ▶ Use personal protective equipment when carrying out any work on the fitting.
 - ▶ Before disposing of the fitting:
 - Collect escaping medium and dispose separately according to local regulations.
 - Neutralize residues of medium in the fitting.
 - ▶ Remove plastic parts and dispose of them in accordance with local regulations.
-
- ▶ Dispose of fitting in accordance with local regulations.

5 Installation and connection

5.1 Preparing for installation

5.1.1 Check operating conditions

1. Ensure the design of the fitting is consistent with the purpose intended:
 - Materials used (→ nameplate).
 - Medium (→ order and design data).
2. Ensure the required operating conditions are met:
 - Resistance of body and seal material to the medium (→ resistance lists).
 - Media temperature (→ 9.2.2 Pressure and temperature limits, Page 12).
 - Working pressure (→ 9.2.2 Pressure and temperature limits, Page 12).
 - Setting range (→ 9.2.1 Setting range, Page 12).
3. Consult with the manufacturer regarding any other use of the device.

5.2 Planning pipelines

5.2.1 Designing pipelines

⚠ WARNING

Risk of poisoning and environmental damage from medium.

Leaks due to impermissible pipework forces.

- ▶ Ensure that the fitting is not subject to any pulling or thrusting forces or bending moments.

NOTE

Damage due to counterpressure!

- ▶ Ensure that the fitting is not loaded due to counterpressure on the secondary side.
- ▶ If necessary, provide a pressure-relief valve directly after the fitting.

1. Plan pipes safely:
 - No pulling or thrusting forces
 - No bending moments
 - Adjust for changes in length due to temperature changes (compensators, expansion shanks)
 - Optional installation position
2. Dimensions (→ Data sheet).

5.3 Installing fitting in pipe

⚠ WARNING

Risk of poisoning and environmental damage from medium.

Leak due to faulty installation.

- ▶ Installation work on the pipes should only be performed by technicians who have been specially trained for the pipework in question.

NOTE

Material damage due to contamination of the fitting!

- ▶ Make sure no contamination reaches the fitting.
- ▶ Flush the pipe with a neutral medium.

 The fitting is installed according to the connection type of the pipes.

 For connection with solvent welding/fusion spigot ends: Use suitable solvent welding/fusion socket ends.

 Observe direction of flow (→ 3.3 Direction of flow, Page 4).

5.3.1 Fixed connection with solvent welding/fusion spigot ends

1. Prepare pipe ends according to connection type.
2. Adhesively apply or weld fitting with solvent welding/fusion socket ends.

5.3.2 Connection with flange

1. Prepare pipe ends according to connection type.
2. Depending on the connection type, insert flat gasket or O-ring.
3. Radially push the fitting between the flange ends.
4. Bolt fitting and flange with flange screws, nuts and washers.
While doing so, observe tightening torques: (→ 9.2.3 Tightening torques, Page 12).

5.4 Performing the hydrostatic test

 Pressure test using neutral medium, e.g. water.

1. Pressurize the fitting, ensuring:
 - Test pressure < permissible system pressure
 - Test pressure < 1.5 PN
 - Test pressure < PN + 5 bar
2. Check the fitting for leaks.

6 Operation

6.1 Set pressure

i Presetting from factory: 0.5 bar (→ 3.1.1 Nameplate, Page 4). Other presetting possible upon consultation with manufacturer.

Set the pressure reducing valve under the same conditions encountered later during operation!

Recommendation for the setting: Installation of a diaphragm guard with manometer in the secondary line of the pressure-relief valve.

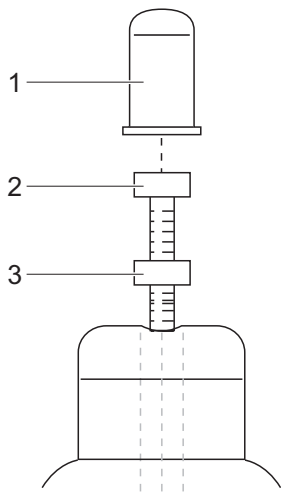

Fig. 4 Set pressure (schematic representation)

- 1 Protection cap
- 2 Adjustment screw
- 3 Counter nut

1. Remove protection cap (1) at adjustment screw (2) from the valve.
2. Undo locknut (3).
3. Turn adjustment screw (2) counter-clockwise until the pressure spring is perceptibly completely relieved of tension.

Valve is open.

4. Start up system.
5. Turn adjustment screw (2) clockwise until desired system pressure is reached.
6. Fix the adjustment screw (2) using a ring wrench, then tighten the locknut (3).

i Adjustment screw can be sealed to prevent unauthorized adjustment, if necessary.

7. Plug on protection cap (1), if present.

6.2 Commissioning

- ✓ Fitting correctly installed and connected

⚠ WARNING

Risk of injury and poisoning due to medium spraying out.

- ▶ Use personal protective equipment when carrying out any work on the fitting.
- ▶ After the initial stresses due to pressure and operating temperature, check if the fitting is sealed.

7 Maintenance

WARNING

Risk of injury and poisoning due to hazardous media liquids!

- ▶ Use personal protective equipment when carrying out any work on the fitting.

7.1 Servicing

1. Visual and function check (every three months):
 - Normal operating conditions unchanged
 - No leaks
 - No unusual operating noises or vibrations
 - Tightening torques of casing screws (→ 9.2.3 Tightening torques, Page 12).
2. Clean fitting with a moist cloth if necessary.

7.2 Maintenance

WARNING

Risk of injury and poisoning due to hazardous or hot media.

- ▶ Use personal protective equipment when carrying out any work on the fitting.
- ▶ Safely collect the media and dispose of it in accordance with environmental regulations.

WARNING

Risk of injury during disassembly!

- ▶ Wear protective gloves, components can be very sharp-edged due to wear or damage.
- ▶ Remove components with springs (e.g. pneumatic drive) carefully, since spring tension can cause components to be ejected.

7.2.1 Removing fitting

1. Ensure that:
 - System is empty
 - System has been flushed
 - System is depressurized
 - System has cooled down
 - System is secured against being switched back on again
2. Remove fitting from the pipe.
3. Decontaminate fitting if required.
 - Dead space in the fitting may still contain medium.

7.2.2 Renew diaphragms and seals

 Drawings: (→ 9.1.3 Drawing DN 80, Page 11).

1. Remove protective cap (10).
2. Undo locknut (9).
3. Unscrew hexagon screw (8) until pressure or disc spring (3/33) is relieved of tension.
 - Attention: Spring must be free of tension.
4. Unscrew screws (12/19) and nuts (23) and remove with washers (24) and tie rods (20).
5. Remove upper part (2) upward.
6. Pull the flange (15) to the bottom.
7. Remove spring plate (7), steel ball (18) and pressure or disc spring (3/33).
8. Remove pressure plate (6).
9. Remove diaphragm (4).
10. Pull piston (5) downward out of the housing (1).
11. Separate piston (5) and lower piston guide (28).
12. Check flat sealing ring (29) and replace if necessary.
13. Check housing (1) in interior (seal seat) for damage.
 - If case of damage, replace housing (1).
14. Assemble piston (5), flat sealing ring (29) and lower piston guide (28) and insert into housing (1) from below.
15. Insert diaphragm (4).
 - Position screw holes above each other.
16. Set pressure plate (6) onto diaphragm (4) and secure to piston (5) with nut (13) or guide pin (26).
17. Insert plug (27).
18. Set pressure or disc spring (3/33), spring plate (7) and steel ball (18) centered on pressure plate (6).
19. Set upper parts (2) onto fitting.
20. Screw tie rods (20) into fitting with washers (24) and nuts (23) and housing screws (12,19) with washers (24) and tighten. (→ 9.2.3 Tightening torques, Page 12).
21. Screw in adjustment screw (8) until spring resistance can be felt.
22. Performing the hydrostatic test (→ 5.4 Performing the hydrostatic test, Page 6).
23. Set pressure (→ 6.1 Set pressure, Page 7).
24. Tighten locknut (9).
25. Put on protective cap (10).

7.3 Replacement parts and return

- Have the following information ready to hand when ordering spare parts (→ nameplate).
 - Fitting type
 - ID number
 - Nominal pressure and diameter
 - Body and seal material
- Please complete and enclose the document of compliance for returns (→ <http://www.asv-stuebbe.com/service/downloads>).



- Only use spare parts from ASV Stübbe.

8 Troubleshooting

WARNING

Risk of injury and poisoning due to hazardous or hot media.

- ▶ Use personal protective equipment when carrying out any work on the fitting.
- ▶ Safely collect the media and dispose of it in accordance with environmental regulations.

Consult with the manufacturer regarding faults which are not identified in the following table, or which cannot be traced to the indicated causes.

Error	Possible cause	Corrective action
Fitting leaky at diaphragm	Insufficient contact pressure (diaphragm fastening)	▶ Retighten screws (12, 19, 23).
	O-ring leaky	▶ Renew O-ring (14, 17) (→ 7.2.2 Renew diaphragms and seals, Page 8).
Pressure rises above permissible value	Diaphragms leaky	▶ Renew diaphragm (4) (→ 7.2.2 Renew diaphragms and seals, Page 8).
	Valve seat leaking	▶ Check piston (5) and/or valve seat and replace, if necessary (→ 7.2.2 Renew diaphragms and seals, Page 8).
	O-ring leaky	▶ Renew O-rings (17, 19) (→ 7.2.2 Renew diaphragms and seals, Page 8).
	Control bore hole (25) in housing and/or intermediate flange soiled	▶ Disassemble and clean fitting (→ 7.2.2 Renew diaphragms and seals, Page 8).
	Piston (5) jams	▶ Disassemble and clean fitting (→ 7.2.2 Renew diaphragms and seals, Page 8).
Valve does not open	Fitting installed in backwards	▶ Install fitting in correction direction (→ 3.3 Direction of flow, Page 4).
Medium is leaking out of the plug/flange (lower part)	O-ring leaky	▶ Dismantle plug/flange (27, 15) and renew O-ring (14) (→ 7.2.2 Renew diaphragms and seals, Page 8).
Medium leaks out at adjustment screw	Diaphragms defective	▶ Renew diaphragm (4) (→ 7.2.2 Renew diaphragms and seals, Page 8).
	Insufficient tightening torque between spring plate, diaphragm and piston	▶ Increase tightening torque on nut (13) or guide pin (16) (→ 9.2.3 Tightening torques, Page 12).

Tab. 3 Troubleshooting

9 Appendix

9.1 Replacement parts and drawings

9.1.1 Part numbers and designations

Item	Designation	Item	Designation
1	Valve body	17	O-ring
2	Upper part	18	Steel ball
3	Pressure spring	19	Screw
4	Diaphragm ¹⁾	20	Threaded rod
5	Piston, complete ¹⁾	21	Manometer ²⁾
6	Spring plate	22	Flat sealing ring
7	Pressure plate	23	nut
8	Adjustment screw	24	Washer
9	Counter nut	25	Control bore hole
10	Cap	26	Hole for mounting mandrel
12	Screw	27	Plug
13	Hexagon nut	28	Lower piston guide
14	O-ring ¹⁾	29	Flat sealing ring
15	Flange	30	O-ring
16	Guide pin	33	Disc spring

Tab. 4 Part designations

1) Spare part

2) – Not included

– Can be obtained for neutral media upon request

– Can be retrofitted for aggressive media with diaphragm pressure gauge guard

9.1.2 Drawing DN 65

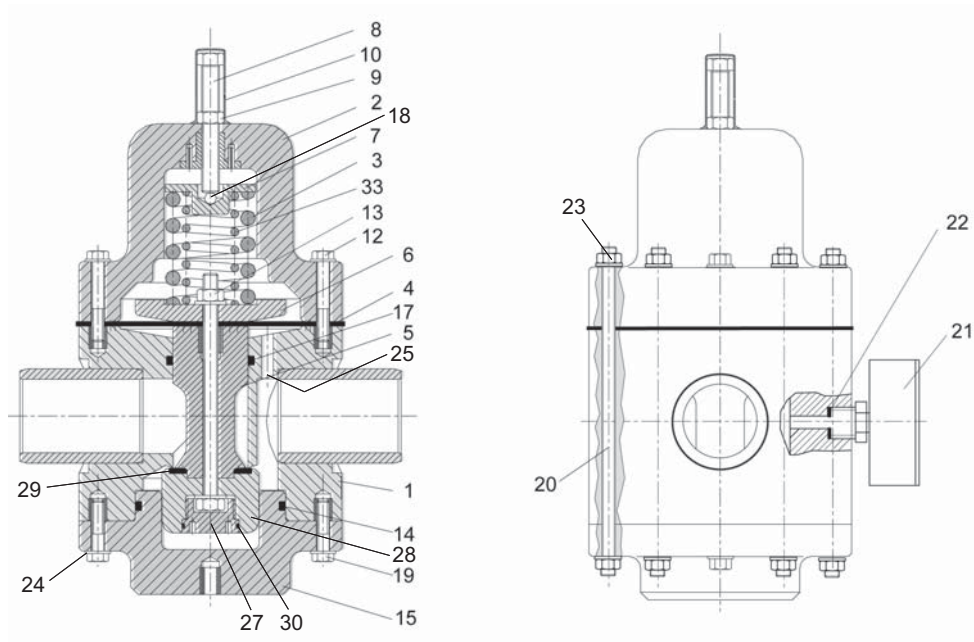

Fig. 5 Drawing DMV 750 – DN 65

9.1.3 Drawing DN 80

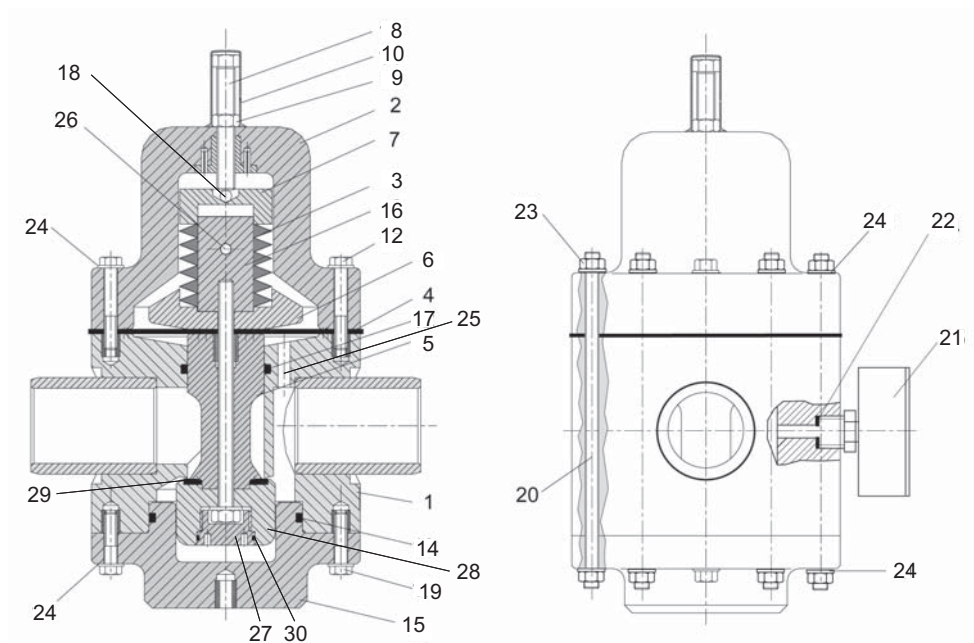

Fig. 6 Drawing DMV 750 – DN 80

9.2 Technical specifications

Technical data (→ Data sheet).

9.2.1 Setting range

1 – 6 bar

9.2.2 Pressure and temperature limits

Other media (→ resistance lists).

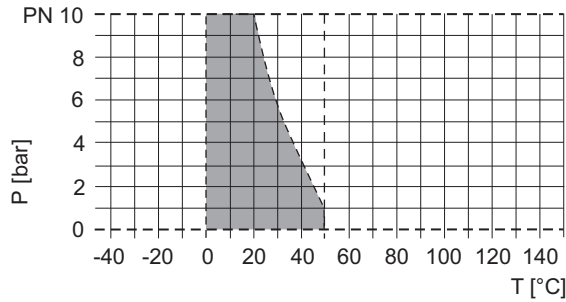

Fig. 7 Pressure and temperature limits PVC-U

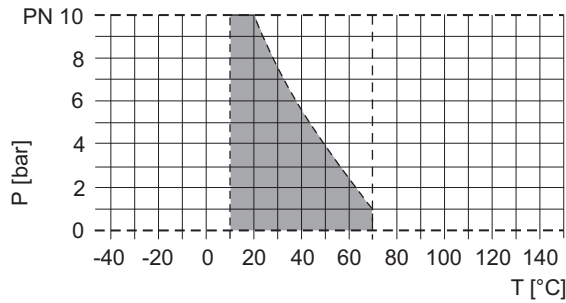

Fig. 8 Pressure and temperature limits PP

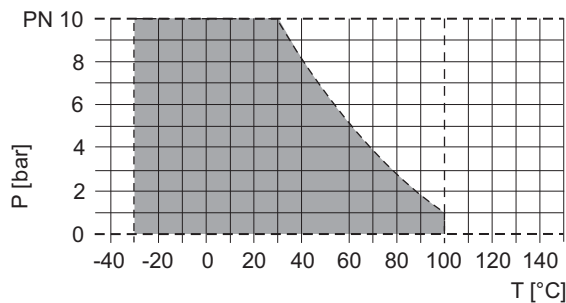

Fig. 9 Pressure and temperature limits PVDF

9.2.3 Tightening torques

Description	Tightening torque [Nm]	
	Size 75	Size 90
Flange screws PVC-U flange	35	40
Flange screws GFK/GFR flange	37	40
Flange screws PP/steel flange	40	40
Housing screw (24)	20 ¹⁾	20 ¹⁾
Manometer (optional)	3	3

Tab. 5 Tightening torques

1) greased

9.3 Installation examples

9.3.1 Secondary pressure – system dynamically flowing

If the stop valve is closed, the working pressure p_A rises by the amount of the closing pressure p_S .

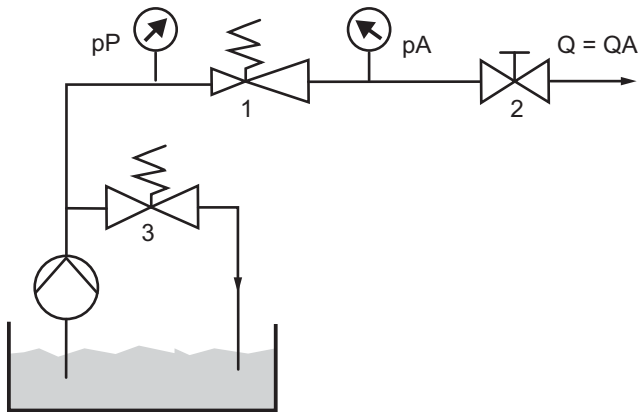

Fig. 10 Example 1: Secondary pressure – system dynamically flowing

9.3.2 Secondary pressure – system closed

If the stop valve is opened, the working pressure p_A drops by the amount of the opening pressure $p_{\ddot{O}}$.

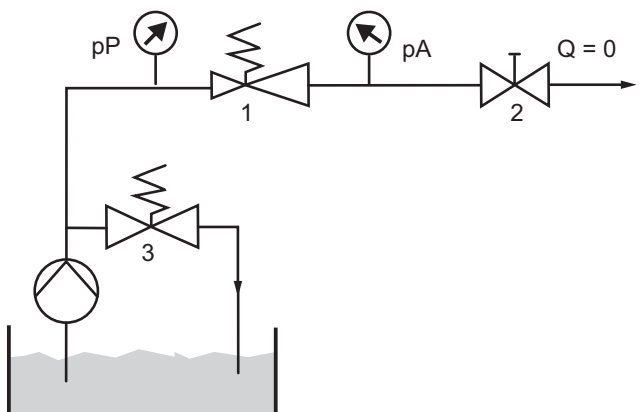

Fig. 11 Example 2: Secondary pressure – system closed

- pP Pump pressure
- pA Working pressure
- 1 Pressure reducing valve
- 2 Shut-off valve
- 3 Pressure relief valve

9.3.3 Operating behavior

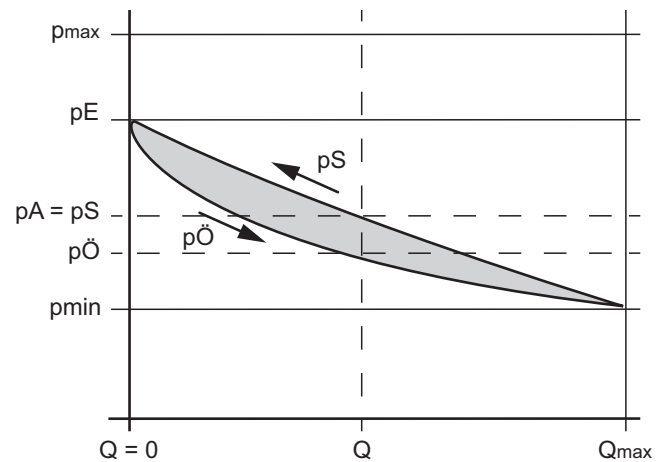

Fig. 12 Operating behavior

- pE Set pressure
- pA Working pressure
- p \ddot{O} Opening pressure
- pS closing pressure
- p \ddot{O} -pS Hysteresis
- pA-pE Flow-dependent pressure reduction
- Q Flow

