

**IDEALARC® DC-600**For use with machines having Code Numbers: **9773 to 10419****Safety Depends on You**

Lincoln arc welding and cutting equipment is designed and built with safety in mind. However, your overall safety can be increased by proper installation ... and thoughtful operation on your part. **DO NOT INSTALL, OPERATE OR REPAIR THIS EQUIPMENT WITHOUT READING THIS MANUAL AND THE SAFETY PRECAUTIONS CONTAINED THROUGHOUT.** And, most importantly, think before you act and be careful.

**OPERATOR'S MANUAL**

World's Leader in Welding and Cutting Products

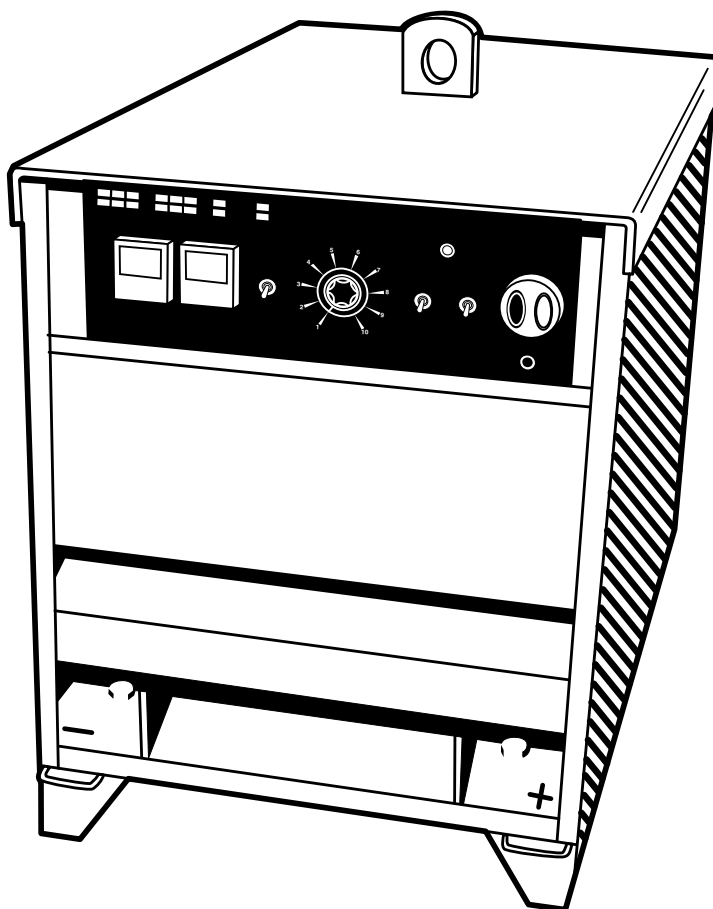

Premier Manufacturer of Industrial Motors

• Sales and Service through Subsidiaries and Distributors Worldwide •

Cleveland, Ohio 44117-1199 U.S.A. TEL: 216.481.8100 FAX: 216.486.1751 WEB SITE: [www.lincolnelectric.com](http://www.lincolnelectric.com)

## ⚠ WARNING



### CALIFORNIA PROPOSITION 65 WARNINGS



Diesel engine exhaust and some of its constituents are known to the State of California to cause cancer, birth defects, and other reproductive harm.

The Above For Diesel Engines

The engine exhaust from this product contains chemicals known to the State of California to cause cancer, birth defects, or other reproductive harm.

The Above For Gasoline Engines

**ARC WELDING CAN BE HAZARDOUS. PROTECT YOURSELF AND OTHERS FROM POSSIBLE SERIOUS INJURY OR DEATH. KEEP CHILDREN AWAY. PACEMAKER WEARERS SHOULD CONSULT WITH THEIR DOCTOR BEFORE OPERATING.**

Read and understand the following safety highlights. For additional safety information, it is strongly recommended that you purchase a copy of "Safety in Welding & Cutting - ANSI Standard Z49.1" from the American Welding Society, P.O. Box 351040, Miami, Florida 33135 or CSA Standard W117.2-1974. A Free copy of "Arc Welding Safety" booklet E205 is available from the Lincoln Electric Company, 22801 St. Clair Avenue, Cleveland, Ohio 44117-1199.

**BE SURE THAT ALL INSTALLATION, OPERATION, MAINTENANCE AND REPAIR PROCEDURES ARE PERFORMED ONLY BY QUALIFIED INDIVIDUALS.**



### FOR ENGINE powered equipment.

1.a. Turn the engine off before troubleshooting and maintenance work unless the maintenance work requires it to be running.



1.b. Operate engines in open, well-ventilated areas or vent the engine exhaust fumes outdoors.



1.c. Do not add the fuel near an open flame welding arc or when the engine is running. Stop the engine and allow it to cool before refueling to prevent spilled fuel from vaporizing on contact with hot engine parts and igniting. Do not spill fuel when filling tank. If fuel is spilled, wipe it up and do not start engine until fumes have been eliminated.

1.d. Keep all equipment safety guards, covers and devices in position and in good repair. Keep hands, hair, clothing and tools away from V-belts, gears, fans and all other moving parts when starting, operating or repairing equipment.

1.e. In some cases it may be necessary to remove safety guards to perform required maintenance. Remove guards only when necessary and replace them when the maintenance requiring their removal is complete. Always use the greatest care when working near moving parts.



1.f. Do not put your hands near the engine fan. Do not attempt to override the governor or idler by pushing on the throttle control rods while the engine is running.

1.g. To prevent accidentally starting gasoline engines while turning the engine or welding generator during maintenance work, disconnect the spark plug wires, distributor cap or magneto wire as appropriate.

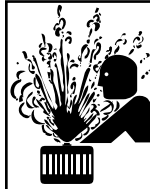

1.h. To avoid scalding, do not remove the radiator pressure cap when the engine is hot.



### ELECTRIC AND MAGNETIC FIELDS may be dangerous

2.a. Electric current flowing through any conductor causes localized Electric and Magnetic Fields (EMF). Welding current creates EMF fields around welding cables and welding machines

2.b. EMF fields may interfere with some pacemakers, and welders having a pacemaker should consult their physician before welding.

2.c. Exposure to EMF fields in welding may have other health effects which are now not known.

2.d. All welders should use the following procedures in order to minimize exposure to EMF fields from the welding circuit:

2.d.1. Route the electrode and work cables together - Secure them with tape when possible.

2.d.2. Never coil the electrode lead around your body.

2.d.3. Do not place your body between the electrode and work cables. If the electrode cable is on your right side, the work cable should also be on your right side.

2.d.4. Connect the work cable to the workpiece as close as possible to the area being welded.

2.d.5. Do not work next to welding power source.

Mar '95



## ELECTRIC SHOCK can kill.

- 3.a. The electrode and work (or ground) circuits are electrically "hot" when the welder is on. Do not touch these "hot" parts with your bare skin or wet clothing. Wear dry, hole-free gloves to insulate hands.
- 3.b. Insulate yourself from work and ground using dry insulation. Make certain the insulation is large enough to cover your full area of physical contact with work and ground.
- In addition to the normal safety precautions, if welding must be performed under electrically hazardous conditions (in damp locations or while wearing wet clothing; on metal structures such as floors, gratings or scaffolds; when in cramped positions such as sitting, kneeling or lying, if there is a high risk of unavoidable or accidental contact with the workpiece or ground) use the following equipment:**
- Semiautomatic DC Constant Voltage (Wire) Welder.
  - DC Manual (Stick) Welder.
  - AC Welder with Reduced Voltage Control.
- 3.c. In semiautomatic or automatic wire welding, the electrode, electrode reel, welding head, nozzle or semiautomatic welding gun are also electrically "hot".
- 3.d. Always be sure the work cable makes a good electrical connection with the metal being welded. The connection should be as close as possible to the area being welded.
- 3.e. Ground the work or metal to be welded to a good electrical (earth) ground.
- 3.f. Maintain the electrode holder, work clamp, welding cable and welding machine in good, safe operating condition. Replace damaged insulation.
- 3.g. Never dip the electrode in water for cooling.
- 3.h. Never simultaneously touch electrically "hot" parts of electrode holders connected to two welders because voltage between the two can be the total of the open circuit voltage of both welders.
- 3.i. When working above floor level, use a safety belt to protect yourself from a fall should you get a shock.
- 3.j. Also see Items 6.c. and 8.



## ARC RAYS can burn.

- 4.a. Use a shield with the proper filter and cover plates to protect your eyes from sparks and the rays of the arc when welding or observing open arc welding. Headshield and filter lens should conform to ANSI Z87.1 standards.
- 4.b. Use suitable clothing made from durable flame-resistant material to protect your skin and that of your helpers from the arc rays.
- 4.c. Protect other nearby personnel with suitable, non-flammable screening and/or warn them not to watch the arc nor expose themselves to the arc rays or to hot spatter or metal.



## FUMES AND GASES can be dangerous.

- 5.a. Welding may produce fumes and gases hazardous to health. Avoid breathing these fumes and gases. When welding, keep your head out of the fume. Use enough ventilation and/or exhaust at the arc to keep fumes and gases away from the breathing zone. **When welding with electrodes which require special ventilation such as stainless or hard facing (see instructions on container or MSDS) or on lead or cadmium plated steel and other metals or coatings which produce highly toxic fumes, keep exposure as low as possible and below Threshold Limit Values (TLV) using local exhaust or mechanical ventilation. In confined spaces or in some circumstances, outdoors, a respirator may be required. Additional precautions are also required when welding on galvanized steel.**
- 5.b. Do not weld in locations near chlorinated hydrocarbon vapors coming from degreasing, cleaning or spraying operations. The heat and rays of the arc can react with solvent vapors to form phosgene, a highly toxic gas, and other irritating products.
- 5.c. Shielding gases used for arc welding can displace air and cause injury or death. Always use enough ventilation, especially in confined areas, to insure breathing air is safe.
- 5.d. Read and understand the manufacturer's instructions for this equipment and the consumables to be used, including the material safety data sheet (MSDS) and follow your employer's safety practices. MSDS forms are available from your welding distributor or from the manufacturer.
- 5.e. Also see item 1.b.

Mar '95



### WELDING SPARKS can cause fire or explosion.

6.a. Remove fire hazards from the welding area. If this is not possible, cover them to prevent the welding sparks from starting a fire.

Remember that welding sparks and hot materials from welding can easily go through small cracks and openings to adjacent areas. Avoid welding near hydraulic lines. Have a fire extinguisher readily available.

- 6.b. Where compressed gases are to be used at the job site, special precautions should be used to prevent hazardous situations. Refer to "Safety in Welding and Cutting" (ANSI Standard Z49.1) and the operating information for the equipment being used.
- 6.c. When not welding, make certain no part of the electrode circuit is touching the work or ground. Accidental contact can cause overheating and create a fire hazard.
- 6.d. Do not heat, cut or weld tanks, drums or containers until the proper steps have been taken to insure that such procedures will not cause flammable or toxic vapors from substances inside. They can cause an explosion even though they have been "cleaned". For information, purchase "Recommended Safe Practices for the Preparation for Welding and Cutting of Containers and Piping That Have Held Hazardous Substances", AWS F4.1 from the American Welding Society (see address above).
- 6.e. Vent hollow castings or containers before heating, cutting or welding. They may explode.
- 6.f. Sparks and spatter are thrown from the welding arc. Wear oil free protective garments such as leather gloves, heavy shirt, cuffless trousers, high shoes and a cap over your hair. Wear ear plugs when welding out of position or in confined places. Always wear safety glasses with side shields when in a welding area.
- 6.g. Connect the work cable to the work as close to the welding area as practical. Work cables connected to the building framework or other locations away from the welding area increase the possibility of the welding current passing through lifting chains, crane cables or other alternate circuits. This can create fire hazards or overheat lifting chains or cables until they fail.
- 6.h. Also see item 1.c.

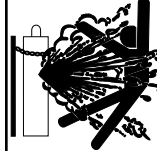

### CYLINDER may explode if damaged.

7.a. Use only compressed gas cylinders containing the correct shielding gas for the process used and properly operating regulators designed for the gas and pressure used. All hoses, fittings, etc. should be suitable for the application and maintained in good condition.

- 7.b. Always keep cylinders in an upright position securely chained to an undercarriage or fixed support.
- 7.c. Cylinders should be located:
  - Away from areas where they may be struck or subjected to physical damage.
  - A safe distance from arc welding or cutting operations and any other source of heat, sparks, or flame.
- 7.d. Never allow the electrode, electrode holder or any other electrically "hot" parts to touch a cylinder.
- 7.e. Keep your head and face away from the cylinder valve outlet when opening the cylinder valve.
- 7.f. Valve protection caps should always be in place and hand tight except when the cylinder is in use or connected for use.
- 7.g. Read and follow the instructions on compressed gas cylinders, associated equipment, and CGA publication P-1, "Precautions for Safe Handling of Compressed Gases in Cylinders," available from the Compressed Gas Association 1235 Jefferson Davis Highway, Arlington, VA 22202.



### FOR ELECTRICALLY powered equipment.

- 8.a. Turn off input power using the disconnect switch at the fuse box before working on the equipment.
- 8.b. Install equipment in accordance with the U.S. National Electrical Code, all local codes and the manufacturer's recommendations.
- 8.c. Ground the equipment in accordance with the U.S. National Electrical Code and the manufacturer's recommendations.

Mar '95

## PRÉCAUTIONS DE SÛRETÉ

Pour votre propre protection lire et observer toutes les instructions et les précautions de sûreté spécifiques qui paraissent dans ce manuel aussi bien que les précautions de sûreté générales suivantes:

### Sûreté Pour Soudage A L'Arc

1. Protégez-vous contre la secousse électrique:
  - a. Les circuits à l'électrode et à la pièce sont sous tension quand la machine à souder est en marche. Eviter toujours tout contact entre les parties sous tension et la peau nue ou les vêtements mouillés. Porter des gants secs et sans trous pour isoler les mains.
  - b. Faire très attention de bien s'isoler de la masse quand on soude dans des endroits humides, ou sur un plancher métallique ou des grilles métalliques, principalement dans les positions assis ou couché pour lesquelles une grande partie du corps peut être en contact avec la masse.
  - c. Maintenir le porte-électrode, la pince de masse, le câble de soudage et la machine à souder en bon et sûr état de fonctionnement.
  - d. Ne jamais plonger le porte-électrode dans l'eau pour le refroidir.
  - e. Ne jamais toucher simultanément les parties sous tension des porte-électrodes connectés à deux machines à souder parce que la tension entre les deux pinces peut être le total de la tension à vide des deux machines.
  - f. Si on utilise la machine à souder comme une source de courant pour soudage semi-automatique, ces précautions pour le porte-électrode s'appliquent aussi au pistolet de soudage.
2. Dans le cas de travail au dessus du niveau du sol, se protéger contre les chutes dans le cas où on reçoit un choc. Ne jamais enrouler le câble-électrode autour de n'importe quelle partie du corps.
3. Un coup d'arc peut être plus sévère qu'un coup de soleil, donc:
  - a. Utiliser un bon masque avec un verre filtrant approprié ainsi qu'un verre blanc afin de se protéger les yeux du rayonnement de l'arc et des projections quand on soude ou quand on regarde l'arc.
  - b. Porter des vêtements convenables afin de protéger la peau de soudeur et des aides contre le rayonnement de l'arc.
  - c. Protéger l'autre personnel travaillant à proximité au soudage à l'aide d'écrans appropriés et non-inflammables.
4. Des gouttes de laitier en fusion sont émises de l'arc de soudage. Se protéger avec des vêtements de protection libres de l'huile, tels que les gants en cuir, chemise épaisse, pantalons sans revers, et chaussures montantes.
5. Toujours porter des lunettes de sécurité dans la zone de soudage. Utiliser des lunettes avec écrans latéraux dans les

zones où l'on pique le laitier.

6. Eloigner les matériaux inflammables ou les recouvrir afin de prévenir tout risque d'incendie dû aux étincelles.
7. Quand on ne soude pas, poser la pince à un endroit isolé de la masse. Un court-circuit accidentel peut provoquer un échauffement et un risque d'incendie.
8. S'assurer que la masse est connectée le plus près possible de la zone de travail qu'il est pratique de le faire. Si on place la masse sur la charpente de la construction ou d'autres endroits éloignés de la zone de travail, on augmente le risque de voir passer le courant de soudage par les chaînes de levage, câbles de grue, ou autres circuits. Cela peut provoquer des risques d'incendie ou d'échauffement des chaînes et des câbles jusqu'à ce qu'ils se rompent.
9. Assurer une ventilation suffisante dans la zone de soudage. Ceci est particulièrement important pour le soudage de tôles galvanisées plombées, ou cadmiées ou tout autre métal qui produit des fumées toxiques.
10. Ne pas souder en présence de vapeurs de chlore provenant d'opérations de dégraissage, nettoyage ou pistolage. La chaleur ou les rayons de l'arc peuvent réagir avec les vapeurs du solvant pour produire du phosgène (gas fortement toxique) ou autres produits irritants.
11. Pour obtenir de plus amples renseignements sur la sûreté, voir le code "Code for safety in welding and cutting" CSA Standard W 117.2-1974.

## PRÉCAUTIONS DE SÛRETÉ POUR LES MACHINES À SOUDER À TRANSFORMATEUR ET À REDRESSEUR

1. Relier à la terre le châssis du poste conformément au code de l'électricité et aux recommandations du fabricant. Le dispositif de montage ou la pièce à souder doit être branché à une bonne mise à la terre.
2. Autant que possible, l'installation et l'entretien du poste seront effectués par un électricien qualifié.
3. Avant de faire des travaux à l'intérieur de poste, la débrancher à l'interrupteur à la boîte de fusibles.
4. Garder tous les couvercles et dispositifs de sûreté à leur place.

Mar. '93

*Thank You* — for selecting a **QUALITY** product by Lincoln Electric. We want you to take pride in operating this Lincoln Electric Company product ••• as much pride as we have in bringing this product to you!

**Please Examine Carton and Equipment For Damage Immediately**

When this equipment is shipped, title passes to the purchaser upon receipt by the carrier. Consequently, Claims for material damaged in shipment must be made by the purchaser against the transportation company at the time the shipment is received.

Please record your equipment identification information below for future reference. This information can be found on your machine nameplate.

Model Name & Number \_\_\_\_\_

Code & Serial Number \_\_\_\_\_

Date of Purchase \_\_\_\_\_

Whenever you request replacement parts for or information on this equipment always supply the information you have recorded above.

**Read this Operators Manual completely** before attempting to use this equipment. Save this manual and keep it handy for quick reference. Pay particular attention to the safety instructions we have provided for your protection. The level of seriousness to be applied to each is explained below:

**⚠ WARNING**

This statement appears where the information **must** be followed **exactly** to avoid **serious personal injury** or **loss of life**.

**⚠ CAUTION**

This statement appears where the information **must** be followed to avoid **minor personal injury** or **damage to this equipment**.

---

<b>Installation .....</b>	<b>Section A</b>
Technical Specifications .....	A-1
Safety Precautions .....	A-2
Select Proper Location.....	A-2
Stacking.....	A-2
Tilting .....	A-2
Electrical Input Connections .....	A-3
Fuses and Wire Sizes.....	A-3
Ground Connection .....	A-3
Input Power Supply Connections.....	A-3
Reconnect Procedure .....	A-4
Output Connections .....	A-7
Electrode and Work Leads .....	A-7
Connection for Wire Feeder Control.....	A-8
Connection for Stick Welding and Air Carbon Arc.....	A-8

---

<b>Operation .....</b>	<b>Section B</b>
Safety Precautions .....	B-1
General Description .....	B-2
Recommended Processes and Equipment .....	B-2
Operational Features and Controls .....	B-2
Design Features and Advantages .....	B-2
Welding Capacity .....	B-3
Controls and Settings .....	B-4
Operating Steps .....	B-5
Remote Control of Machine Operation .....	B-5
Welding Procedure Recommendations .....	B-5 — B-8
Semi-Automatic and Automatic Wire Feeding	
with a DC-600 and Wire Feeders .....	B-6
NA-3 Automatic Wire Feeder.....	B-6
NA-5 Automatic Wire Feeder.....	B-8
LN-8 Semi-Automatic Wire Feeder.....	B-8
LN-7 & LN-9 Semi-Automatic Wire Feeders.....	B-8

---

<b>Accessories .....</b>	<b>Section C</b>
Accessories .....	C-1
Multi-Process Switch .....	C-1
Undercarriage.....	C-3
Meters.....	C-3
Paralleling Kit.....	C-3
Connections for Wire Feeder Control.....	C-4
NA-3 .....	C-4
NA-5 .....	C-5
LN-8 or LN-9.....	C-6
LN-7.....	C-7

---

---

<b>Maintenance .....</b>	<b>Section D</b>
Safety Precautions .....	D-1
Routine and Periodic Maintenance.....	D-2
3-D Exploded View .....	D-3

---

<b>Troubleshooting .....</b>	<b>Section E</b>
Safety Precautions.....	E-1
How to Use Troubleshooting Guide.....	E-1
Troubleshooting Guide .....	E-2

---

<b>Wiring Diagrams .....</b>	<b>Section F</b>
------------------------------	------------------

---

<b>Parts List .....</b>	<b>P282 Series</b>
-------------------------	--------------------



## TECHNICAL SPECIFICATIONS - IDEALARC DC-600

<b>INPUT - THREE PHASE ONLY</b>				
<u>Standard Voltage</u>		<u>Input Current at Rated Output</u>		
208/230/416/460/575/3/60		125/113/63/57/45		
<b>RATED OUTPUT</b>				
<u>Duty Cycle</u>		<u>AMPS</u>		<u>Volts at Rated Amps</u>
100%		600		44
60%		680		44
50%		750		44
<b>OUTPUT</b>				
<u>Mode</u>	<u>Current Range</u>	<u>Maximum Open Circuit Voltage</u>		<u>Auxiliary Power</u>
Constant Current Constant Voltage	90 to 850 Amps 70 to 850 Amps	72 VDC 55 VDC		115 VAC, 8 Amps
<b>RECOMMENDED INPUT WIRE AND FUSE SIZES</b>				
Input Voltage / Frequency	Fuse (Super Lag) or Breaker Size	Input Ampere Rating on Nameplate	Type 75°C Copper Wire in Conduit AWG (IEC) Sizes	Type 75°C Copper Ground Wire in Conduit AWG (IEC) Sizes
208/60	175	125	2 (35mm <sup>2</sup> )	6 (16 mm <sup>2</sup> )
230/60	175	113	2 (35mm <sup>2</sup> )	6 (16 mm <sup>2</sup> )
416/60	100	63	6 (16mm <sup>2</sup> )	8 (10 mm <sup>2</sup> )
460/60	90	57	6 (16mm <sup>2</sup> )	8 (10 mm <sup>2</sup> )
575/60	80	45	6 (16mm <sup>2</sup> )	8 (10 mm <sup>2</sup> )
<b>PHYSICAL DIMENSIONS</b>				
<u>Height</u>	<u>Width</u>	<u>Depth</u>	<u>Weight</u>	
30.75 in. (781 mm.)	22.25 in. (567 mm.)	39.0 in. (988 mm.)	522 lbs. (237 kg.)	

Read entire Installation Section before installing the IDEALARC DC-600.

## SAFETY PRECAUTIONS

### ⚠ WARNING

## ELECTRIC SHOCK CAN KILL.



- Only qualified personnel should install this machine.

- Turn the input power OFF at the disconnect switch or fuse box before working on the equipment.

- Do not touch electrically hot parts.

- Always connect the IDEALARC DC-600 grounding terminal to a good electrical earth ground.

- Set the IDEALARC DC-600 Power ON/OFF PUSH BUTTON to the OFF position when connecting power cord to input power.

## SELECT PROPER LOCATION

Place the IDEALARC DC-600 where clean air can freely circulate in through the front intake and out through the rear louvers. Dirt, dust, or any foreign material that can be drawn into the machine should be kept at a minimum. Not following these precautions can result in the nuisance shutdown of the machine because of excessive operating temperatures.

## STACKING

Three IDEALARC DC-600 machines can be stacked.

DO NOT stack more than three machines in one grouping.

DO NOT stack the IDEALARC DC-600 on another type of machine.

Follow these guidelines when stacking:

1. Select a firm, level surface capable of supporting the total weight of up to three machines (1570 pounds/712 kilograms).
2. Set the bottom machine in place.
3. Stack the second machine on top of it by aligning the two holes in the base rails of the second machine with the two pins on top front of the bottom machine.
4. Repeat process for third machine.

NOTE: The machines must be stacked with the Case Front of each machine flush with each other. See Figure A.1.

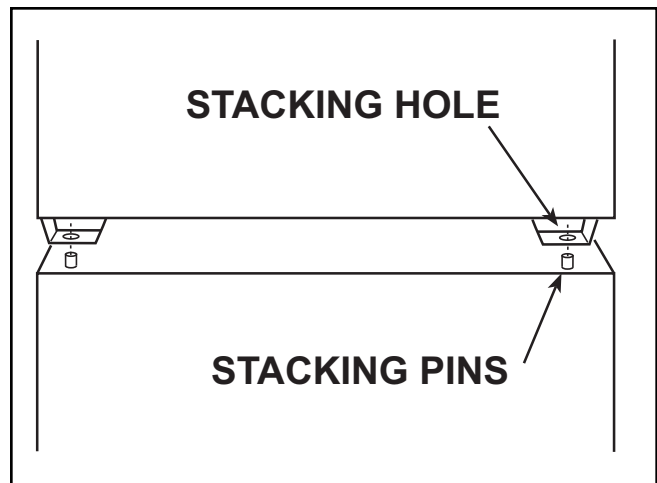

**FIGURE A.1 - Stacking IDEALARC DC-600 machines**

## TILTING

The IDEALARC DC-600 must be placed on a stable, level surface so it will not topple over.

## ELECTRICAL INPUT CONNECTIONS

Before installing the machine, check that the input supply voltage, phase, and frequency are the same as the machine's voltage, phase, and frequency as specified on the machine's rating plate on the Case Front Assembly Control Panel. Input power supply entry is through the hole in the Case Back Assembly. See Figure A.2 for the location of the machine's input cable entry opening, Input Contactor (CR1), and reconnect panel assembly for dual voltage machines.

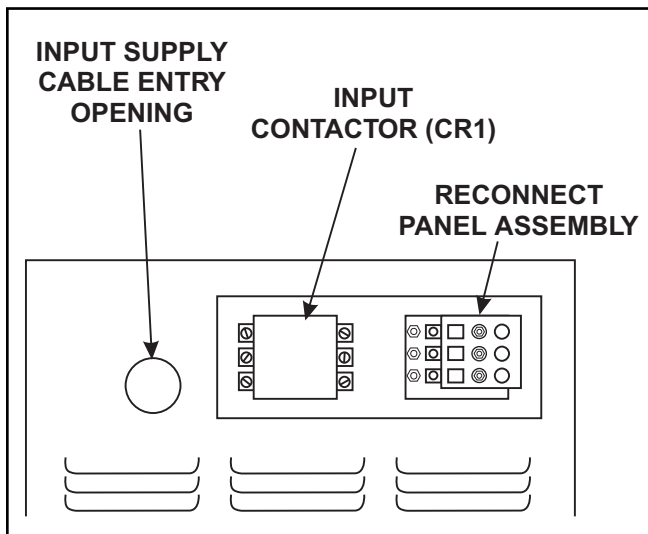

FIGURE A.2 - Rear Panel

## FUSE AND WIRE SIZES

Protect the input circuit with the super lag fuses or delay type circuit breakers listed on the Technical Specifications page of this manual for the machine being used. They are also called inverse time or thermal/magnetic circuit breakers.

DO NOT use fuses or circuit breakers with a lower amp rating than recommended. This can result in "nuisance" tripping caused by inrush current even when machine is not being used for welding at high output currents.

Use input and grounding wire sizes that meet local electrical codes or see the Technical Specifications page in this manual.

## GROUND CONNECTION

Ground the frame of the machine. A ground terminal marked with the symbol ( $\oplus$ ) is located inside the Case Back of the machine near the input contactor. Access to the Input Box Assembly is at the upper rear of the machine. See your local and national electrical codes for proper grounding methods.

## INPUT POWER SUPPLY CONNECTIONS

A qualified electrician should connect the input power supply leads.

1. Follow all national and local electrical codes.
2. Follow Input Supply Connection Diagram located on the inside of the machine.
3. Use a three-phase line.
4. Remove Input Access Door at upper rear of machine.
5. Connect the three-phase AC power supply leads L1, L2, and L3 to the input contactor terminals in the Input Box Assembly by passing them thru the three aligned .50" diameter holes in the baffle and tighten them in the terminal connectors. Be sure to close the baffle by inserting the tab into the slot in the baffle. See Figure A.3.

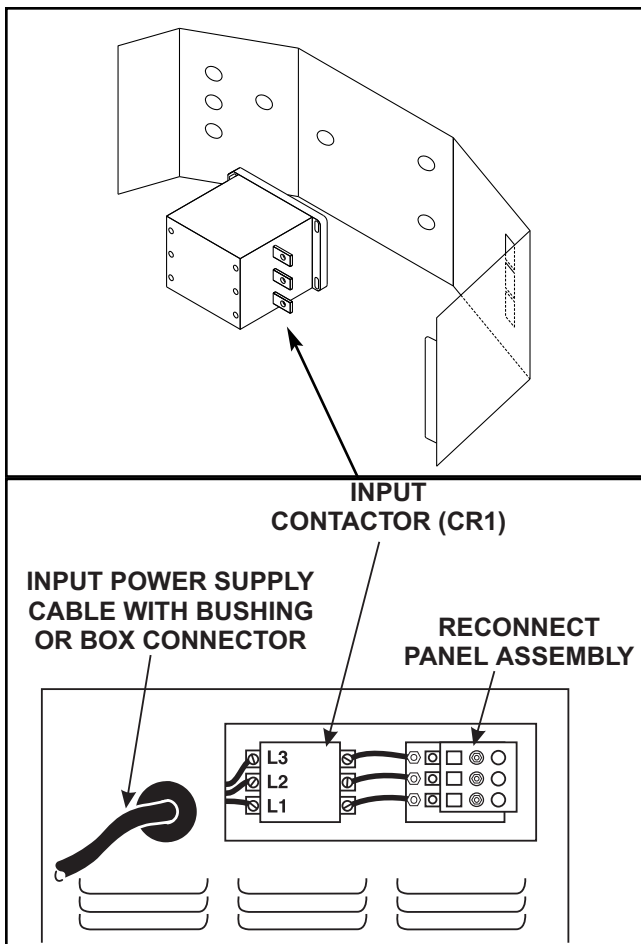

FIGURE A.3 - Input Power Supply Connections

## RECONNECT PROCEDURE

Multiple voltage machines are shipped connected to the highest input voltage listed on the machine's rating plate. Before installing the machine, check that the Reconnect Panel in the Input Box Assembly is connected for the proper voltage.

### CAUTION

Failure to follow these instructions can cause immediate failure of components within the machine.

To reconnect a multiple voltage machine to a different voltage, remove input power and change the position of the reconnect board on the Reconnect Panel. Follow The Input Connection Diagram located on the inside of Case Back Input Access Door. These connection diagrams for the following codes are listed below.

1. For Dual Voltage except 380/500-460/575, see Figure A.4. (M15009)
2. For 220/380/460, see Figure A.5. (M15010)
3. For 380/500-460/575, see Figure A.6. (M15011)
4. For Single Voltage, see Figure A.7. (S17894)
5. For 230/460/575, see Figure A.8. (M15666)
6. For Voltages not listed, see the Input Connection Diagram pasted on the inside of the Case Back Input Access Door.

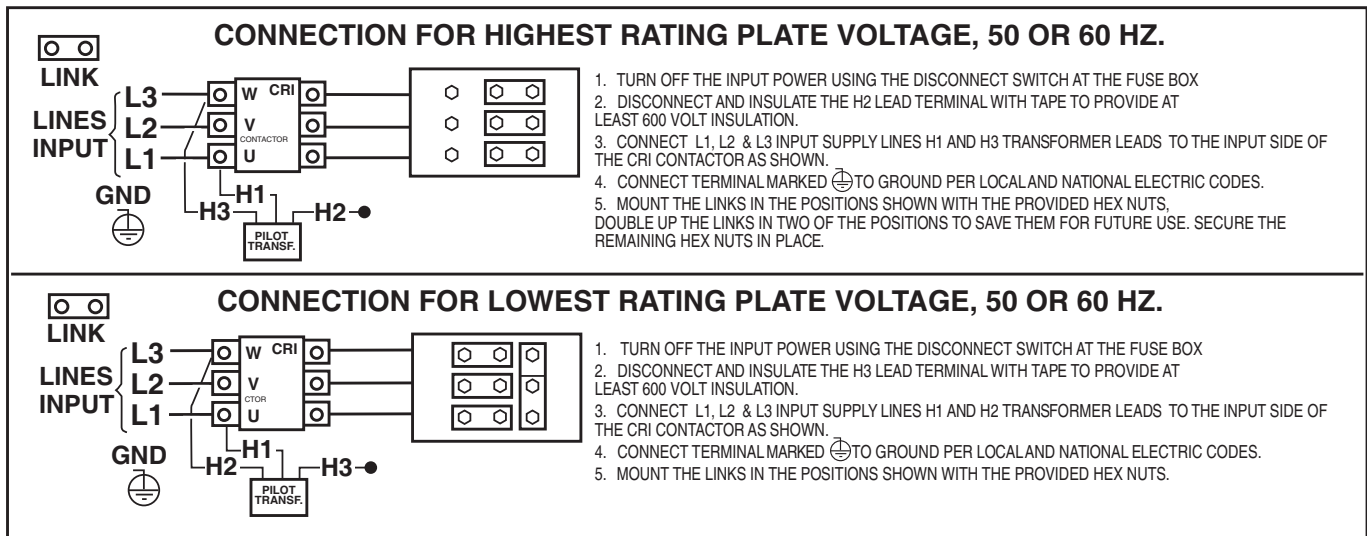
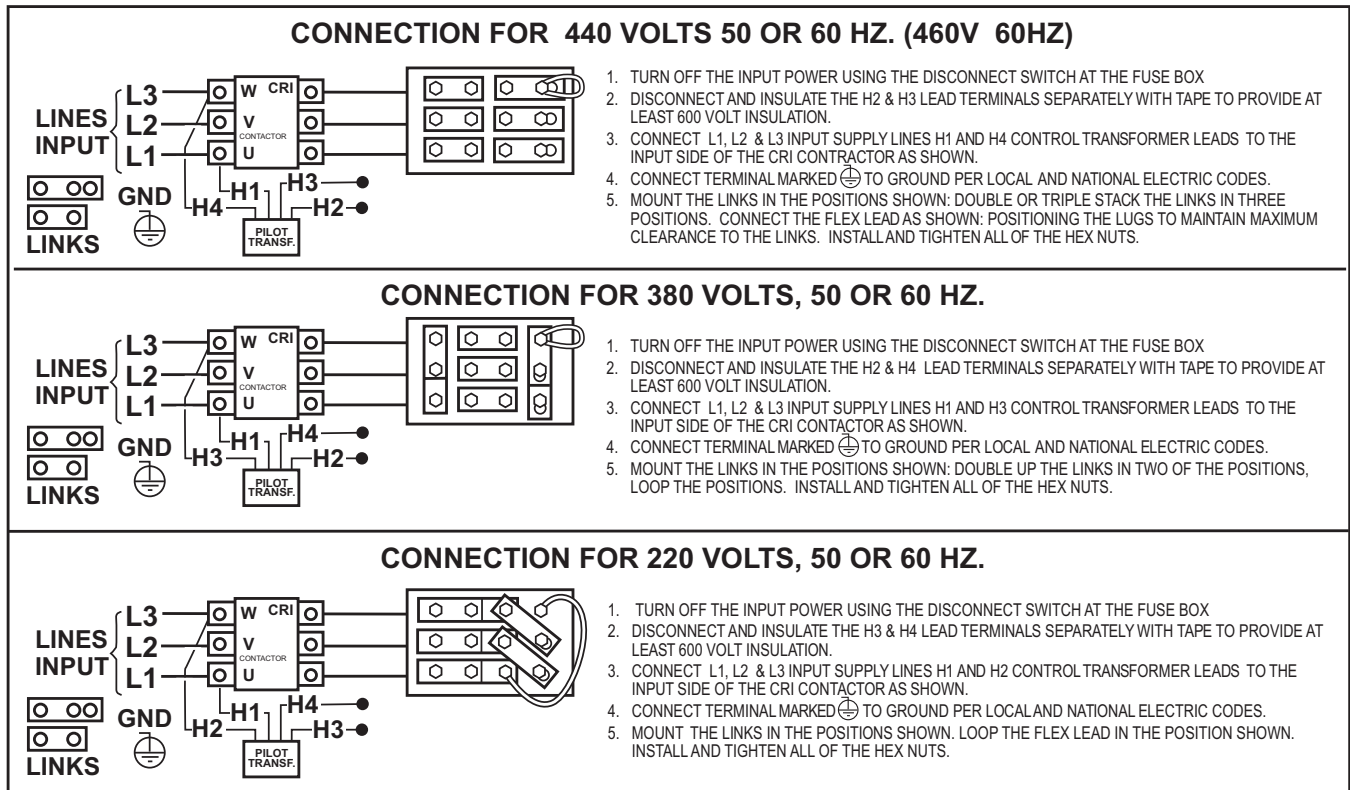
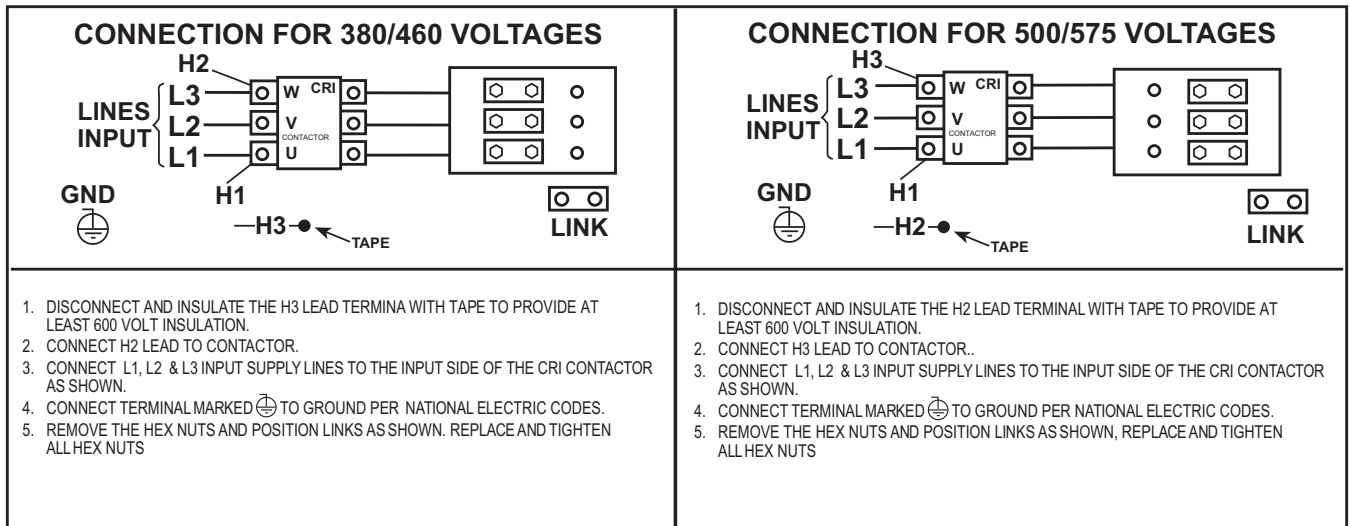

FIGURE A.4-Reconnect Panel Board Positions for Dual Voltage Machines



**FIGURE A.5-Reconnect Panel Board Positions for 220/380/440 VAC Machines**



**FIGURE A.6-Reconnect Panel Board Positions for 380/500, 460/575 VAC Machines**

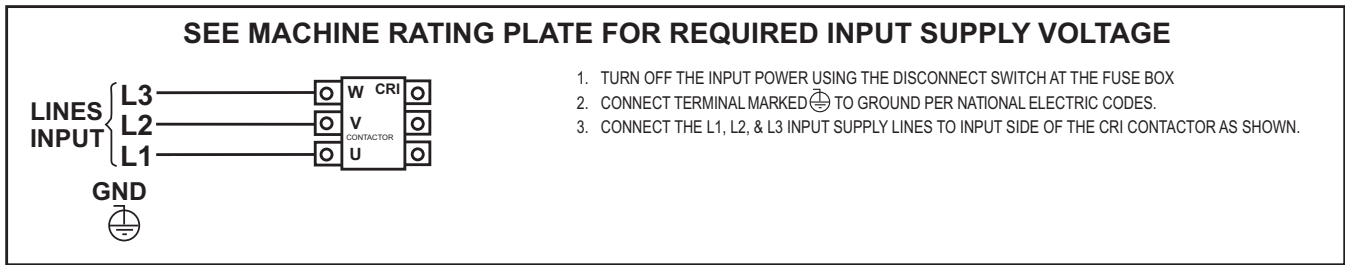

**FIGURE A.7-Reconnect Panel Board Positions for Single Voltage Machines**

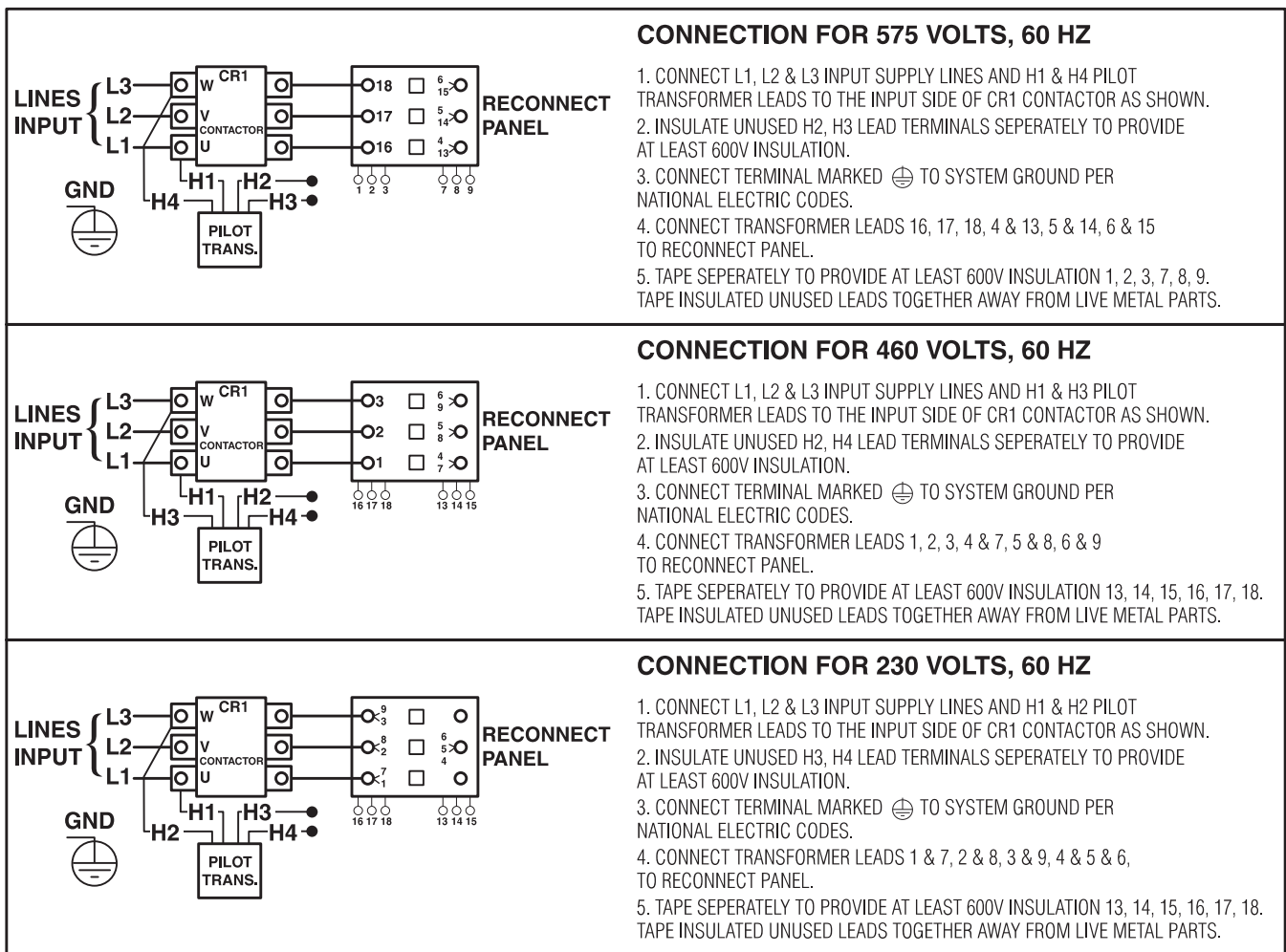

**FIGURE A.8-Reconnect Panel Board Positions for 230/460/575 VAC Machines**

## OUTPUT CONNECTIONS

See Table A.1 for recommended IDEALARC DC-600 cable sizes for combined lengths of electrode and work cables.

**TABLE A.1**  
**IDEALARC DC-600 Cable Sizes for Combined Lengths of Electrode and Work Cable (Copper)**  
**at 100% Duty Cycle**

Cable Length	Parallel Cables	Cable Size
Lengths up to 150 ft. (46m)	2	1/0 (53mm <sup>2</sup> )
150 ft.(46m) to 200 ft (61m)	2	2/0 (67mm <sup>2</sup> )
200 ft.(61m) to 250 ft.(76m)	2	3/0 (85mm <sup>2</sup> )

### Connect Electrode and Work Leads to Output Terminals.

1. Set the ON/OFF PUSH BUTTON to OFF.
2. Locate the retractable strain relief loops directly below the output terminals in the lower right and lower left corners of the Case Front Assembly. See Figure A.9.
3. Pull out the retractable strain relief loops.
4. Insert the electrode lead through the loop directly below the desired polarity (positive or negative). Pull through enough cable to reach the output terminals.
5. Connect electrode lead to the desired terminal (positive/negative).
6. Tighten the output terminal nut with a wrench.
7. Connect the work lead to the other output terminal following steps 4-6.

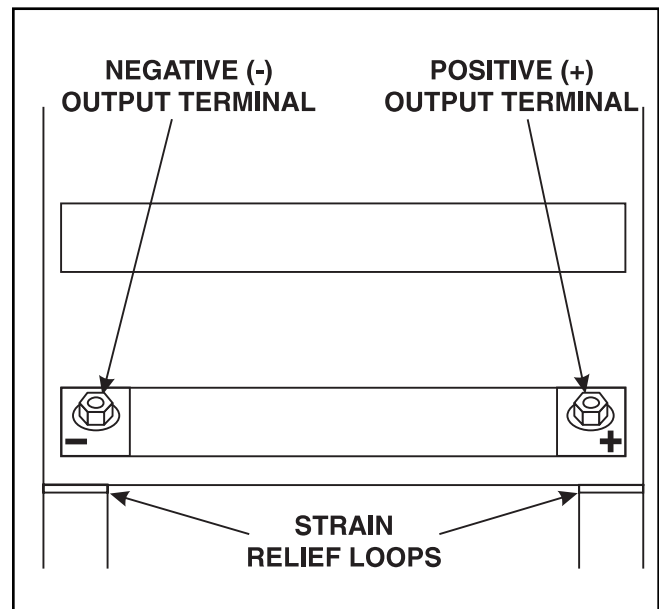

**FIGURE A.9 - Output Terminals.**

### Connection For Semi-Automatic or Automatic Wire Feeder Control

NOTE: See the ACCESSORIES Section of this manual for specific instructions on connecting the following semi-automatic and automatic wire feeders:

- LN-7 } Semi-Automatic Wire Feeders
- LN-8 } Semi-Automatic Wire Feeders
- LN-9 } Semi-Automatic Wire Feeders
- NA-3 } Automatic Wire Feeders
- NA-5 } Automatic Wire Feeders
- LT-7 } Tractors
- LT-56 } Tractors

### Connection for Stick Welding and Air/Carbon Arc Cutting Operation

#### **WARNING**

THE OUTPUT TERMINALS ARE ENERGIZED AT ALL TIMES WHEN THE IDEALARC DC-600 IS CONNECTED FOR STICK WELDING AND AIR/CARBON ARC CUTTING.

1. Set ON/OFF PUSH BUTTON to OFF.
2. Locate and open the hinged access door on the Front Case Assembly.
3. If necessary, disconnect all wire feeder control cable connections from the DC-600 terminal strip.
4. Remove the leads from the unit by pulling them through and out of the strain relief loops.
5. Connect a jumper wire from terminal #2 to terminal #4 on the terminal strip.
6. Set the Welding Mode Switch to the VV position for both stick welding and air/carbon arc cutting.

NOTE: To use the IDEALARC DC-600 for both stick welding / air/carbon arc cutting, AND semi-automatic / automatic welding, the optional Multi-Process Switch (K804) must be used. See the ACCESSORIES Section of this manual for instructions on installing and using the Multi-Process Switch. When the Multi-Process Switch is not used, all control, work, and electrode leads from semi-automatic or automatic wire feeders must be disconnected from the IDEALARC DC-600 before connecting the machine for stick welding or air/carbon arc cutting.



## OPERATING INSTRUCTIONS

Read and understand entire section before operating machine.

---

### SAFETY PRECAUTIONS

#### WARNING



#### **ELECTRIC SHOCK can kill.**

- Do not touch electrically live parts or electrode with skin or wet clothing.
  - Insulate yourself from work and ground.
  - Always wear dry insulating gloves.
- 



#### **FUMES AND GASES can be dangerous.**

- Keep your head out of fumes.
  - Use ventilation or exhaust to remove fumes from breathing zone.
- 



#### **WELDING, CUTTING and GOUGING SPARKS can cause fire or explosion**

- Keep flammable material away.
  - Do not weld, cut or gouge on containers that have held combustibles.
- 



#### **ARC RAYS can burn.**

- Wear eye, ear and body protection.

Observe additional Safety Guidelines detailed in the beginning of this manual.

IDEALARC DC-600



## GENERAL DESCRIPTION

The IDEALARC DC-600 is an SCR controlled three phase welding and cutting power source. It uses a single range potentiometer to control:

- Submerged Arc Semi-Automatic or Automatic Welding
- Open Arc Semi-Automatic or Automatic Welding
- Stick Welding (Standard on All Machines)
- Air/Carbon Arc Cutting (Carbon Rod Sizes up to 3/8" Diameter)

The IDEALARC DC-600 has a three-position Welding Mode Switch to enable the user to operate in one of three modes:

- Constant Voltage (CV) Submerged Arc
- Constant Voltage (CV) Innershield
- Constant Current (CC) Stick

The IDEALARC DC-600 can be easily connected to wire feeding equipment, including:

- Semi-automatic wire feeders LN-7, LN-8, and LN-9
- Automatic wire feeders NA-3 and NA-5
- Tractors LT-56 and LT-7

The optional Multi-Process Switch allows the user to switch between semi-automatic or automatic welding and stick welding or air/carbon arc cutting without disconnecting the wire feeder equipment control, electrode, and work leads.

## RECOMMENDED PROCESSES AND EQUIPMENT

The IDEALARC DC-600 is recommended for the following welding or cutting processes within its output capacity of 70 amps to 850 amps in the Constant Voltage mode and 90 amps to 850 amps in the Constant Current mode:

- Submerged Arc Semi-Automatic or Automatic Welding
- Open Arc Semi-Automatic or Automatic Welding
- Stick Welding (Standard on All Machines)
- Air/Carbon Arc Cutting (Carbon Rod Sizes up to 3/8" Diameter)

## OPERATIONAL FEATURES AND CONTROLS

The IDEALARC DC-600 comes with the following standard controls:

- ON/OFF PUSH BUTTON
- OUTPUT CONTROL POTENTIOMETER
- OUTPUT CONTROL SWITCH (Remote or Panel)
- WELDING MODE SWITCH
- CONTROL CIRCUIT POLARITY SWITCH
- POWER SOURCE PILOT LIGHT
- DC AMMETER (OPTIONAL)
- DC VOLTMETER (OPTIONAL)

## DESIGN FEATURES AND ADVANTAGES

The following list of design features will help you understand the machine's total capabilities and how you can take advantage of them to get maximum use of your machine.

- Excellent arc characteristics for optimum constant voltage submerged arc and Innershield welding performance.
- A control circuit designed to provide good starting for a large variety of processes and procedures.
- Output Control Potentiometer that provides easy single range continuous control.
- Output Control Switch that provides simple switching from local to remote control.
- Red neon pilot light to confirm that the Input Contactor is energized.

- Auxiliary power source to provide 115-volt AC power (1000 VA) to wire feeding equipment.
- Multi-functional terminal strip for easy connection of wire feeding control cables and switching between CV Innershield and CV Submerged Arc welding when using the Dual Process or Dual Procedure Kits.
- Recessed output terminals to avoid any person or object from accidentally coming into contact with the output terminals and labeled positive and negative for easy identification.
- Thermostatically protected power source.
- Electronic protection circuit to protect power source against overloads.
- Input line voltage compensation to provide an essentially constant output.
- SCR electronically controlled welder output provides extra long life, especially for highly repetitive welding applications.
- Three circuit solid state control system provides maximum performance and circuit protection.
- Low profile case provides maximum use of space.
- Convenient access to all controls.
- Output lead strain relief loops to prevent terminal and cable damage.
- Easily removed case side, even when stacked.
- Outdoor operation because enclosure is designed with air intake louvers that keep dripping water from entering the unit. Transformer, SCR bridge, and choke have special corrosion resistant paint for added protection.

## WELDING CAPABILITY

The IDEALARC DC-600 has the following duty cycle ratings:

If the duty cycle is exceeded, a thermal protector will shut off the output of the machine until it cools to the normal operating temperature.

Duty Cycle	Amps	Volts	Hertz
50% (Based on 10 min.)	750	44	50/60
60% (Based on 10 min.)	680	44	50/60
100%	600	44	50/60

## CONTROLS AND SETTINGS

All operator controls and adjustments are located on the Case Front Assembly of the IDEALARC DC-600. See Figure B.1 for the location of each control.

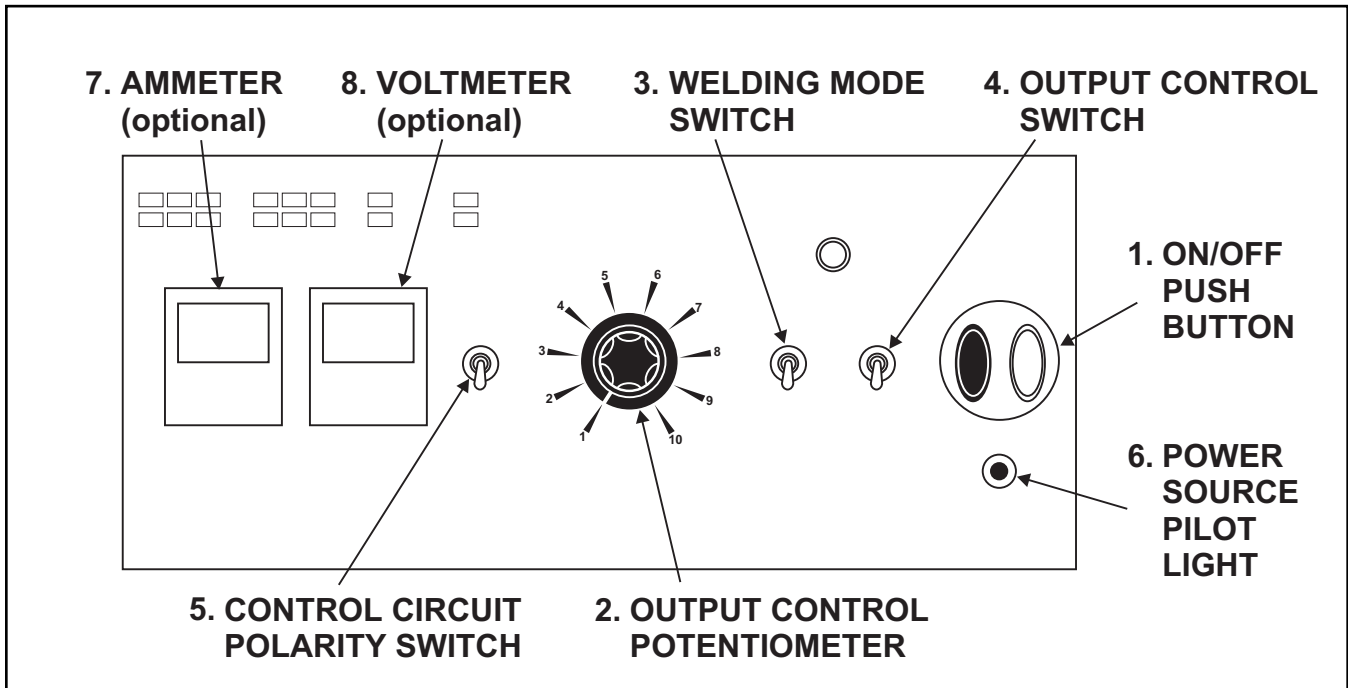

**FIGURE B.1 - CONTROL PANEL KEYS**

1. **ON/OFF PUSH BUTTON:** This push button turns the machine ON or OFF.
2. **OUTPUT CONTROL POTENTIOMETER:** This control provides tapered, continuous control of the machine output. The control can be rotated from minimum to maximum while machine is under load to adjust the machine output.
3. **WELDING MODE SWITCH:** This toggle switch is used to select the proper welder performance characteristics for the process being used. There are three modes: CV (Constant Voltage) Submerged Arc, CV (Constant Voltage) Innershield, and CC (Constant Current) Stick.
4. **OUTPUT CONTROL SWITCH:** This toggle switch is used to switch between "Panel" for local control of machine output and "Remote" for remote control of machine output.
5. **CONTROL CIRCUIT POLARITY SWITCH:** This toggle switch is used to set power source voltage sensing polarity to match the polarity to which the electrode is connected to the machine. This provides the correct polarity at the terminal strip for correct operation of the automatic wire feeding equipment powered by the auxiliary power from the power source.
6. **POWER SOURCE PILOT LIGHT:** The red neon light glows when the power source input contactor is energized.
7. **AMMETER:** An optional ammeter is available.
8. **VOLTMETER:** An optional voltmeter is available.

## OPERATING STEPS

The following procedures are for using the IDEAL-ARC DC-600 in the local control mode of operation. For remote control of the machine, see the Remote Control of Machine Operation section.

Before operating the machine, make sure you have all materials needed to complete the job. Be sure you are familiar with and have taken all possible safety precautions before starting work. It is important that you follow these operating steps each time you use the machine.

1. Turn on the main AC power supply to the machine.
2. Set the CONTROL CIRCUIT POLARITY SWITCH to the appropriate position.
  - Set toggle to "Electrode Negative" position if the electrode is connected to the negative (-) output terminal.
  - Set toggle to "Electrode Positive" position if the electrode is connected to the positive (+) output terminal.
3. Set the WELDING MODE SWITCH to welding process being used.
  - CV Submerged Arc
  - CV Innershield
  - CC Stick
4. Push the ON/OFF PUSH BUTTON to the ON position
  - The red neon light glows.
  - The fan starts.
5. Set Output Control Potentiometer to desired voltage or current.
6. Make the weld (NOTE: Terminal #2 and #4 must be connected together to energize the machine output).

## REMOTE CONTROL OF MACHINE OPERATION

The toggle switch on the control panel labeled "Remote - Panel" gives the operator the option of controlling the machine output from a remote location. If in the Remote position a wire feeder with remote control capabilities or a remote control device such as a K775 must be connected to terminals 75, 76, and 77. Refer to Accessories Section for wire feeder remote information.

## WELDING PROCEDURE RECOMMENDATIONS

Select Welding Mode Switch position based on type of welding to be done.

1. Innershield Welding/Other Open Arc Processes: Use the CV Innershield mode.
2. Submerged Arc Welding: Use the CV Submerged Arc mode. If performing high speed welding, switch between the CV Submerged Arc and the CV Innershield mode and use the mode that produces the best welding results.
3. Air/Carbon Arc Cutting / Stick Welding / High Current, Large Puddle Submerged Arc Welding: Use the CC Stick mode. When the IDEALARC DC-600 is used for Air/Carbon Arc cutting, the OUTPUT CONTROL POTENTIOMETER should be set to "9" initially. Based on the size of the carbon being used or the process, turn the potentiometer to a lower setting as required by the process. You can use carbon rods up to 3/8" in diameter at currents as high as 750 amps with excellent arc control. The welder protection circuit protects the machine from extremely high short circuiting pulses.

## SEMI-AUTOMATIC AND AUTOMATIC WIRE FEEDING WITH A IDEALARC DC-600 AND WIRE FEEDERS

When using the IDEALARC DC-600 with semi-automatic or automatic wire feeding equipment and for stick welding or air/carbon arc cutting, it is recommended that the optional MULTI-PROCESS SWITCH be used. This switch permits you to easily change the polarity of the connected wire feeding equipment or switch to stick welding or air/carbon arc cutting.

### NA-3 AUTOMATIC WIRE FEEDER

1. Set the DC-600 Output Control Switch to Remote. NOTE: Later model NA-3 automatic wire feeders are capable of cold starts when the NA-3 Mode switch is in the CV or CC mode position. Some earlier models are capable of cold starting only in the CC mode position. Cold starting enables you to inch the wire down to the work, automatically stop, and automatically energize the flux hopper valve.
2. Set the DC-600 welding mode switch for the desired process: CV Submerged Arc, CV Innershield mode or CC mode.
3. Set the NA-3 mode Switch Position to either CV or CC to match the DC-600 mode selected in step 2.
4. Refer to the NA-3 operators manual for instructions on how to use the NA-3 in conjunction with the DC-600.
5. Follow the following guidelines for good arc striking detailed below for each welding mode.

### GOOD ARC STRIKING GUIDELINES FOR THE NA-3 WITH THE IDEALARC DC-600 IN THE CV INNERSHIELD, CV SUBMERGED ARC OR CC STICK WELDING MODES.

Following are some basic arc striking techniques that apply to all wire feed processes. Using these procedures should provide trouble-free starting. These procedures apply to single, solid wires and Innershield wires.

1. Cut the electrode to a sharp point.

2. Set the NA-3 Open Circuit Voltage Control to the same dial setting as the Arc Voltage Control. If this is a new welding procedure, a good starting point is to set the Open Circuit Voltage Control to # 6.

NOTE: The open circuit voltage of the IDEALARC DC-600 varies from approximately 16 volts to 56 volts in the CV Innershield or CV Submerged Arc modes. The open circuit voltage is constant in the CC Stick mode.

3. Run a test weld. Set proper current, voltage, and travel speed.
  - a. For the best starting performance, the NA-3 Open Circuit Voltage Control and Voltage Control setting should be the same. Set the Inch Speed Control for the slowest inch speed possible.
  - b. To adjust the Open Circuit Voltage Control to get the best starting performance, make repeated starts observing the NA-3 voltmeter.

When the voltmeter pointer swings smoothly up to the desired arc voltage, without undershooting or overshooting the desired arc voltage, the Open Circuit Voltage Control is set properly.

If the voltmeter pointer overshoots the desired voltage and then returns back to the desired voltage, the Open Circuit Voltage Control is set too high. This can result in a bad start where the wire tends to "Blast off."

If the voltmeter pointer hesitates before coming up to the desired voltage, the Open Circuit Voltage Control is set too low. This can cause the electrode to stub.

4. Start and make the weld.
  - a. Cold starts. For cold starts, be sure the work piece is clean and the electrode makes positive contact with the work piece.
  - b. Hot "On the Fly" starts. For hot starts, travel should begin before the wire contacts the work piece.

### ARC STRIKING WITH IDEALARC DC-600 AND THE NA-3 START BOARD

When electrical strikeouts exceed 1 3/4" (44.4mm) an NA-3 Start Board may be required to improve arc striking.

When the NA-3 Start Board is used to improve arc striking, use the following procedures:

1. Set start time at 0.
2. Set NA-3 start current and start voltage at mid-range.
3. Set the NA-3 output current and voltage to the proper settings for the welding procedure to be used.
4. Turn the Start Board Timer to maximum.
5. Set Start Board current and voltage control.
  - a. Set the Start Board current control to 1 1/2 dial numbers below that set on the NA-3 current control.
  - b. Set the Start Board voltage control equal with the NA-3 voltage control setting.

NOTE: These Start Board current and voltage settings result in a start up current that is lower than the NA-3 current setting and approximately equal with the NA-3 voltage setting for the desired welding procedure.

6. Establish the correct arc striking procedure with the NA-3 Start Board timer set at maximum.
  - a. For the best starting performance, the NA-3 Open Circuit Voltage Control and Voltage Control setting should be the same. Set the Inch Speed Control for the slowest inch speed possible.
  - b. To adjust the Open Circuit Voltage Control to get the best starting performance, make repeated starts observing the NA-3 voltmeter.

When the voltmeter pointer swings smoothly up to the desired arc voltage, without undershooting or overshooting the desired arc voltage, the Open Circuit Voltage Control is set properly.

If the voltmeter pointer overshoots the desired voltage and then returns back to the desired voltage, the Open Circuit Voltage Control is set too high. This can result in a bad start where the wire tends to "Blast off."

If the voltmeter pointer hesitates before coming up to the desired voltage, the Open Circuit Voltage Control is set too low. This can cause the electrode to stub.

- c. Set NA-3 Start Board current and voltage as close to the welding procedure current and voltage as possible.

NOTE: The Start Board current and voltage should be as close as possible to the welding procedure current and voltage, while still getting satisfactory starts.

- d. Set the start time to as low a time as possible while still getting satisfactory starts.

7. Start and make the weld.

## IDEALARC DC-600 POWER SOURCE SETTING WHEN CONNECTED TO NA-5 WIRE FEEDER

When using the IDEALARC DC-600 with the NA-5 wire feeder, set the controls on the IDEALARC DC-600 as follows for the best performance:

1. Turn OFF main AC input power supply to the IDEALARC DC-600.
2. Connect the electrode cables to terminal polarity to be used.
3. Set the CONTROL CIRCUIT POLARITY SWITCH to the same polarity as the electrode cable connection.
4. Set the OUTPUT CONTROL SWITCH to REMOTE.
5. Set the IDEALARC DC-600 WELDING MODE SWITCH to the position that matches the welding process being used.
  - a. For submerged arc welding, set WELDING MODE SWITCH TO CV SUBMERGED ARC position.
  - b. For all open arc welding processes set WELDING MODE SWITCH TO CV INNER-SHIELD position.

## LN-8 SEMI-AUTOMATIC WIRE FEEDER

To use the LN-8 Semi-Automatic Wire Feeder with IDEALARC DC-600

1. Set the IDEALARC DC-600 WELDING MODE SWITCH to either CV Innershield mode or CV Submerged Arc mode depending on the welding process being used.
2. Set the IDEALARC DC-600 OUTPUT CONTROL SWITCH to the REMOTE position.
3. Set the LN-8 Welding Mode Switch to the CV position. The LN-8 Welding Mode Switch is located on the variable voltage (CC) board.
4. Refer to the LN-8 Operator's Manual for instructions on how to use the LN-8.

## LN-7 AND LN-9 SEMI-AUTOMATIC WIRE FEEDERS OR OTHER CONSTANT WIRE FEEDERS

To use the LN-7, LN-9, or other constant wire feed speed semi-automatic wire feeders with IDEALARC DC-600

1. Set the IDEALARC DC-600 WELDING MODE SWITCH to either CV Innershield mode or CV Submerged Arc mode depending on the welding process being used.

NOTE: These semi-automatic wire feeders cannot be used in the CC Stick mode.

2. Set the IDEALARC DC-600 OUTPUT CONTROL SWITCH.
  - a. LN-7: Use either an optional K775 Remote Control Box Assembly or set the IDEALARC DC-600 OUTPUT CONTROL SWITCH in the Local position.
  - b. LN-9: Refer to the LN-9 Operator's Manual for instructions of how to use the LN-9.



## OPTIONS/ACCESSORIES

- Multi-Process Switch (K804)
- Remote Control Box Assembly (K775)
- Undercarriages ( K817P, K842)
- Paralleling Kit (S20428)

### Semi-Automatic and Automatic Wire Feeders

- LN-7
  - LN-8
  - LN-9
- } Semi-Automatic Wire Feeders
- NA-3
  - NA-5
- } Automatic Wire Feeders

## MULTI-PROCESS SWITCH

The MULTI-PROCESS SWITCH gives you the ability to:

- Switch between "stick welding or air/carbon arc cutting" and using a semi-automatic or automatic wire feeder.
- Change the polarity of a semi-automatic or automatic wire feeder without changing any electrical cable connections.

See Figure C.1

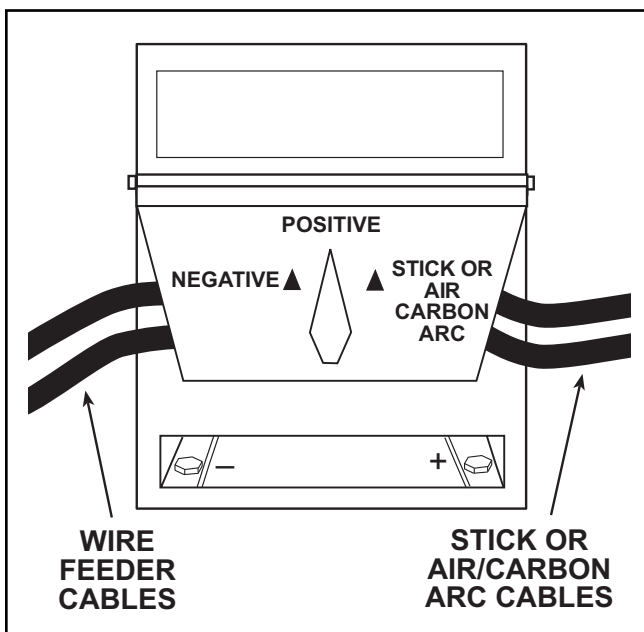

FIGURE C.1 - MULTI-PROCESS SWITCH

The MULTI-PROCESS SWITCH has two sets of output terminals. You connect the wire feeder unit cables to the set of terminals on the left side of the box and the stick or air/carbon arc cables to the set of terminals on the right side (facing the front of the machine) as shown in Figure C.1.

When the MULTI-PROCESS SWITCH is in the "Stick or Air/Carbon Arc" position, only those terminals are energized. The wire feeder nozzle or gun and electrode are not electrically "hot" when in this mode.

Follow these steps to install the MULTI-PROCESS SWITCH:

1. Confirm that the IDEALARC DC-600 ON/OFF PUSH BUTTON is in the OFF position.
2. Disconnect main AC input power to the IDEALARC DC-600.
3. Open the terminal strip access door located on the Case Front Assembly.
4. Remove the two front, middle screws that secure the two side panels of the machine. See Figure C.2.

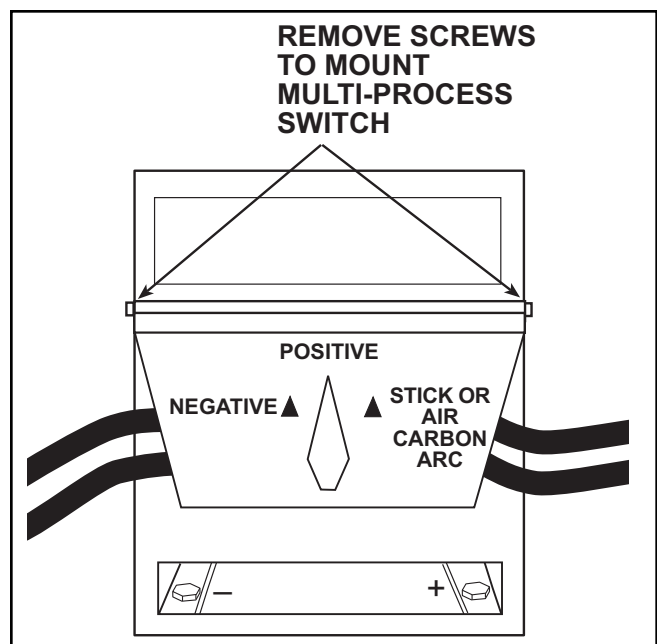
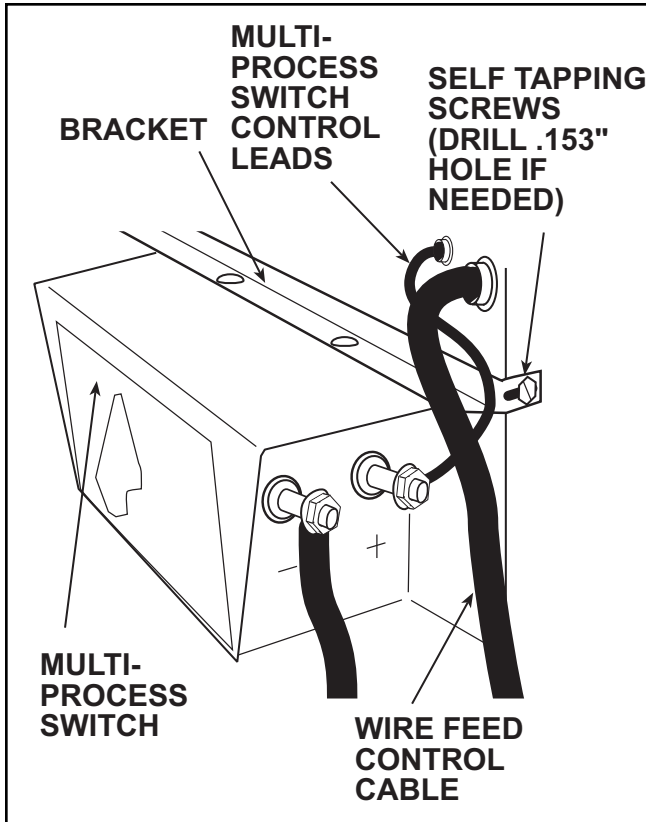

FIGURE C.2 - SIDE PANEL REMOVAL

- Attach the MULTI-PROCESS SWITCH bracket across the front of the machine with the flange down. Use the long, self-tapping screws and lock washers provided. The bracket should be on the outside of the side panel. See Figure C.3.

NOTE: If the machine does not have any holes in the front of the machine, use the switch template and drill two .153" diameter holes.

- Position the MULTI-PROCESS SWITCH at the front of the machine. See Figure C.3.



**FIGURE C.3 - ATTACHING THE MULTI-PROCESS SWITCH BRACKET.**

- Route the MULTI-PROCESS SWITCH control leads through the strain-relief box connectors and into the terminal strip. The wire feeder control cable is routed through the strain-relief box connector also. See Figure C.3.

- Connect the control leads from the MULTI-PROCESS SWITCH to terminals #2 and #4 on the IDEALARC DC-600's terminal strip.
- Position the MULTI-PROCESS SWITCH flush with the front of the machine about 2" lower than the bracket. Slide the switch straight up to the bracket.
- Check that the bottom of the switch is hooked behind the top of the bottom louver.
- Connect the right cable from the MULTI-PROCESS SWITCH (facing the front of the machine) to the IDEALARC DC-600 positive (+) output terminal. See Figure C.4.

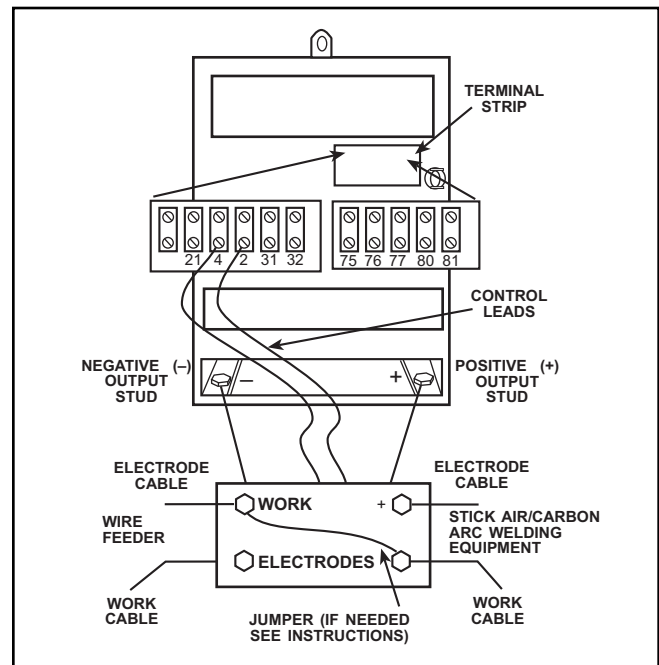

**FIGURE C.4 - MULTI-PROCESS SWITCH CABLE CONNECTIONS.**

- Connect the left cable from the MULTI-PROCESS SWITCH (facing the front of the machine) to the IDEALARC DC-600 negative (-) output terminal. See Figure C.4.

13. Connect the wire feeder electrode and work cables. See Figure C.4.

- a. Insert the wire feeder electrode and work cables through the strain relief loop on the left side of the IDEALARC DC-600 (facing the front of the machine).
- b. Connect the wire feeder electrode and work cables to the electrode and work terminals on the left side of the MULTI-PROCESS SWITCH.

NOTE: When using Dual Process Kits K317 or K318, connect the electrode and work cables to these terminals instead of the power source output terminals. See connection diagrams for details.

14. Connect wire feeder control cable to the terminal strip of the IDEALARC DC-600.

NOTE: Connect the control cable ground lead to the frame terminal marked (  ).

NOTE: See the connection diagram for the wire feeder being used for connection instructions.

15. Connect stick or air/carbon arc electrode and work cable. See Figure C.4.

- a. Insert the electrode and work cables through the strain relief loop on the right side (facing the front of the machine) of the IDEALARC DC-600.
- b. Connect the electrode cable to the "Positive" terminal on the right side of the MULTI-PROCESS SWITCH.
- c. Connect the work cable to the "Negative" terminal on the right side of the MULTI-PROCESS SWITCH.

NOTE: The instructions above are for connecting the stick polarity positive. To change the polarity, turn the IDEALARC DC-600 OFF, and reverse the cables.

NOTE: When it is not necessary to have separate ground cables for stick and semi-automatic or automatic welding, connect a jumper from the MULTI-PROCESS SWITCH "Work" terminal to the MULTI-PROCESS SWITCH "negative" terminal. See Figure C.4.

To operate the MULTI-PROCESS SWITCH, refer to the operating instructions on the switch nameplate.

## UNDERCARRIAGE (K817P, K842)

The IDEALARC DC-600 is designed for use with the Lincoln K817P, or K842 Undercarriage. Complete installation instructions are included with the undercarriage. When any of the undercarriages are installed, the IDEALARC DC-600 lift bail is no longer functional. Do not attempt to lift the machine with the undercarriage attached. The undercarriage is designed for moving the machine by hand only. Mechanized towing can lead to injury and/or damage to the IDEALARC DC-600.

## METERS

Optional factory-installed voltmeter and ammeter are available.

## PARALLELING KIT FOR DC-600

Kit S20428 - field installation only, permits paralleling of two DC-600's for welding currents of up to 1200 amps, 100% duty cycle. (See instructions shipped with the kit for installation and operation.)

## CONNECTIONS FOR SEMI-AUTOMATIC OR AUTOMATIC WIRE FEEDER CONTROL

1. Set the ON/OFF PUSH BUTTON to OFF.
2. Locate and open the hinged access door on the Front Case Assembly.
3. Insert control cable through the strain relief box connector and pull enough cable through to reach the terminal strip.
4. Connect the automatic wire feeder control cable to the terminal strip. See corresponding connection diagram in this Section of the manual, or the instructions included with the wire feeder.
5. Connect the wire feeder grounding wire to the chassis ground screw marked with the symbol ( $\text{⏏}$ ).

NOTE: The IDEALARC DC-600 Auxiliary Power Circuit supplies 115-volt AC power to the wire feeding equipment. The circuit has a 1000 volt ampere rating. An 8-amp slow blow fuse on the machine's control panel protects the auxiliary power supply from excessive overloads.

### CONNECTING THE NA-3 IDEALARC DC-600

1. Disconnect main AC input power to the IDEALARC DC-600.
2. Set IDEALARC DC-600 ON/OFF PUSH BUTTON to OFF.
3. Connect the wire feeder control cable leads to the IDEALARC DC-600 terminal strip as shown in Figure C.5.
4. Connect the wire feeder control cable ground lead to the frame terminal marked ( $\text{⏏}$ ).

NOTE: The IDEALARC DC-600 must be properly grounded.

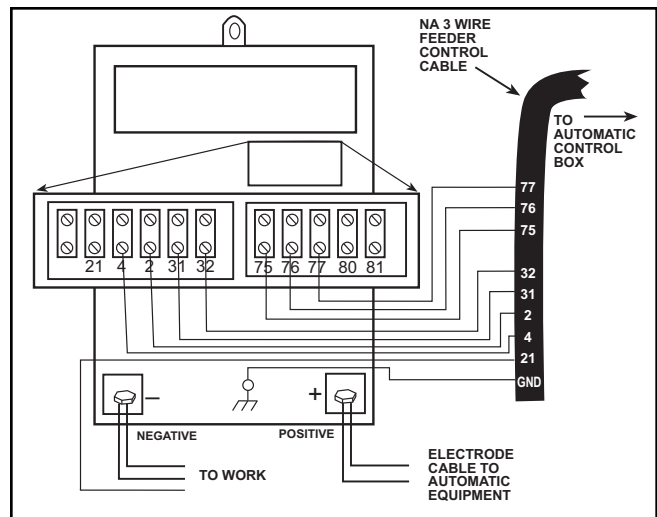

**FIGURE C.5 - NA-3 WIRE FEEDER CONNECTION TO THE IDEALARC DC-600**

5. Extend wire feeder control cable lead # 21 so it can be connected directly to the work piece.
  - a. Make a bolted connection using AWG #14 or larger insulated wire. Tape the bolted connection with insulating tape.
  - b. An S-16586- X remote voltage sensing work lead is available for this purpose.
  - c. Keep the # 21 lead electrically separate from the work cable circuit and connection.
  - d. Tape the # 21 lead to work cable for ease of use.

NOTE: The connection diagram shown in Figure C.5 shows the electrode connected for positive polarity. To change polarity:

- a. Set the IDEALARC DC-600 ON/OFF PUSH BUTTON to OFF
- b. Move the electrode cable to the Negative (-) output terminal
- c. Move the work cable to the Positive (+) output terminal.
- d. Set the IDEALARC DC-600 CONTROL CIRCUIT POLARITY SWITCH to NEGATIVE.
- e. Reverse the leads at the back of the ammeter and voltmeter on the wire feeder automatic control box.

## CONNECTING THE NA-5 TO THE IDEALARC DC-600

NOTE: For optimum performance use the NA-5 with IDEALARC DC-600 codes 8288 and above.

1. Disconnect main AC input power to the IDEALARC DC-600.
2. Set the IDEALARC DC-600 ON/OFF PUSH BUTTON to OFF.
3. Connect the wire feeder control cable leads to the IDEALARC DC-600 terminal strip as shown in Figure C.6.

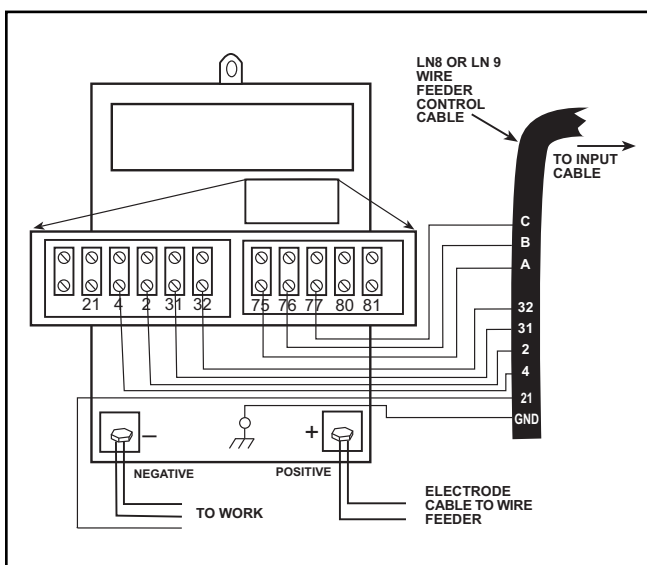

**FIGURE C.6 - NA-5 WIRE FEEDER CONNECTION TO THE IDEALARC DC-600**

NOTE: If using a K215 control cable, connect control cable leads #75, #76, and #77 to the matching #75, #76, and #77 terminals on the terminal strip of the IDEALARC DC-600.

4. Connect the wire feeder control cable ground lead to the frame terminal marked (⏏).  
NOTE: The IDEALARC DC-600 must be properly grounded.

5. Extend wire feeder control cable lead # 21 so it can be connected directly to the work piece.
  - a. Make a bolted connection using AWG #14 or larger insulated wire. Tape the bolted connection with insulating tape.
  - b. An S-16586- X remote voltage sensing work lead is available for this purpose.
  - c. Keep the # 21 lead electrically separate from the work cable circuit and connection.
  - d. Tape the # 21 lead to work cable for ease of use.
6. Connect NA-5 wire feeder control jumpers on Voltage Control Board. See NA-5 Operator's Manual.

- a. Connect red jumper on Voltage Control Board to pin "S."
- b. Connect white jumper on Voltage Control Board to pin "B."

NOTE: The connection diagram shown in Figure C.6 shows the electrode connected for positive polarity. To change polarity:

- a. Set the IDEALARC DC-600 ON/OFF PUSH BUTTON to OFF.
- b. Move the electrode cable to the Negative (-) output terminal.
- c. Move the work cable to the Positive (+) output terminal.
- d. Set the IDEALARC DC-600 CONTROL CIRCUIT POLARITY SWITCH to NEGATIVE.

NOTE: For proper NA-5 operation, the electrode cables must be secured under the clamp bar on the left side of the NA-5 Control Box.

## CONNECTING THE LN-8 OR LN-9 TO THE IDEALARC DC-600

1. Disconnect AC input power to the IDEALARC DC-600.
2. Set the IDEALARC DC-600 ON/OFF PUSH BUTTON to OFF.
3. Connect the wire feeder control cable leads to the IDEALARC DC-600 terminal strip as shown in Figure C.7.
4. Connect the wire feeder control cable ground lead to the frame terminal marked (  ).  
NOTE: The IDEALARC DC-600 must be properly grounded.

5. Extend wire feeder control cable lead #21 so it can be connected directly to the work piece.
  - a. Make a bolted connection using AWG #14 or larger insulated wire. Tape the bolted connection with insulating tape.
  - b. An S-16586- X remote voltage sensing work lead is available for this purpose.
  - c. Keep the #21 lead electrically separate from the work cable circuit and connection.
  - d. Tape the #21 lead to work cable for ease of use.

NOTE: Using the extended #21 lead eliminates the need to use the LN-9's remote work lead accessory which has a direct work lead jack.

6. Connect LN-9 wire feeder control jumpers on Voltage Control board. See LN-9 Operator's Manual.
  - a. White jumper on Voltage Control Board to pin "S."
  - b. Blue jumper on Voltage Control Board to pin "B."

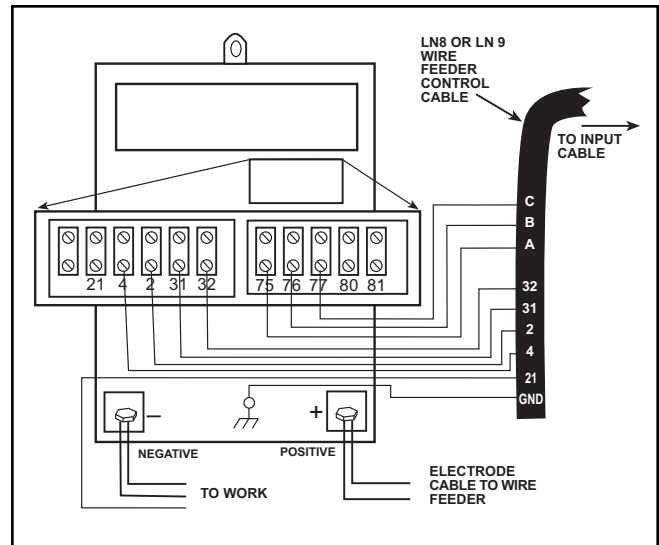

**FIGURE C.7 - LN-8 OR LN-9 WIRE FEEDER CONNECTION TO THE IDEALARC DC-600**

NOTE: On earlier units, the blue jumper on Voltage Control Board is connected to Pin "B" on Start Board.

NOTE: The connection diagram shown in Figure C.7 shows the electrode connected for positive polarity. To change polarity:

- a. Set the IDEALARC DC-600 ON/OFF PUSH BUTTON to OFF
- b. Move the electrode cable to the Negative (-) output terminal
- c. Move the work cable to the Positive (+) output terminal.
- d. Set the IDEALARC DC-600 CONTROL CIRCUIT POLARITY SWITCH to NEGATIVE.

### LN-7 IDEALARC DC-600

1. Disconnect main AC input power to the IDEALARC DC-600.
2. Set the IDEALARC DC-600 ON/OFF PUSH BUTTON to OFF.
3. Connect the wire feeder control cable leads to the IDEALARC DC-600 terminal strip as shown in Figure C.8.

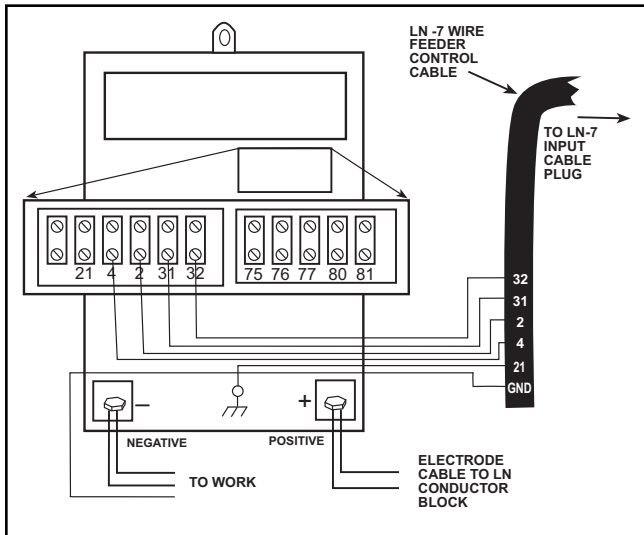

**FIGURE C.8 - LN-7 WIRE FEEDER CONNECTION TO THE IDEALARC DC-600**

4. Connect the wire feeder control cable ground lead to the frame terminal marked (  $\text{⏏}$  ).  
NOTE: The IDEALARC DC-600 must be properly grounded.
5. PERFORM THIS STEP ONLY IF THE LN-7 IS EQUIPPED WITH A METER KIT.

Extend wire feeder control cable lead #21 so it can be connected directly to the work piece.

- a. Make a bolted connection using AWG #14 or larger insulated wire. Tape the bolted connection with insulating tape.

NOTE: If the work cable length is less than 25 feet and the connections to the work piece are secure, then wire feeder control cable lead #21 can be connected directly to the DC-600 terminal strip.

- b. An S-16586- X remote voltage sensing work lead is available for this purpose.
- c. Keep the #21 lead electrically separate from the work cable circuit and connection.
- d. Tape the #21 lead to work cable for ease of use.

NOTE: The connection diagram shown in Figure C.8 shows the electrode connected for positive polarity. To change polarity:

- a. Set the IDEALARC DC-600 ON/OFF PUSH BUTTON to OFF.
- b. Move the electrode cable to the Negative (-) output terminal.
- c. Move the work cable to the Positive (+) output terminal.
- d. Set the IDEALARC DC-600 CONTROL CIRCUIT POLARITY SWITCH to NEGATIVE.

## MAINTENANCE

## SAFETY PRECAUTIONS

**⚠ WARNING****ELECTRIC SHOCK  
CAN KILL.**

Only qualified personnel should perform this maintenance.

Turn the input power OFF at the disconnect switch or fuse box before working on this equipment.

Do not touch electrically hot parts.



## ROUTINE AND PERIODIC MAINTENANCE

1. Disconnect input AC power supply lines to the machine before performing periodic maintenance, tightening, cleaning, or replacing parts. See Figure D.1

### Perform the following daily:

1. Check that no combustible materials are in the welding or cutting area or around the machine.
2. Remove any debris, dust, dirt, or materials that could block the air flow to the machine for cooling.
3. Inspect the electrode cables for any slits or punctures in the cable jacket, or any condition that would affect the proper operation of the machine.

### Perform Periodically:

Clean the inside of the machine with low pressure air stream. Clean the following parts. Refer to Figure D.1.

- Main transformer and choke.
- Electrode and work cable connections.
- SCR rectifier bridge and heat sink fins.
- Control board.
- Firing board.
- Fan Assembly.  
NOTE: The fan motor has sealed bearings which require no maintenance.

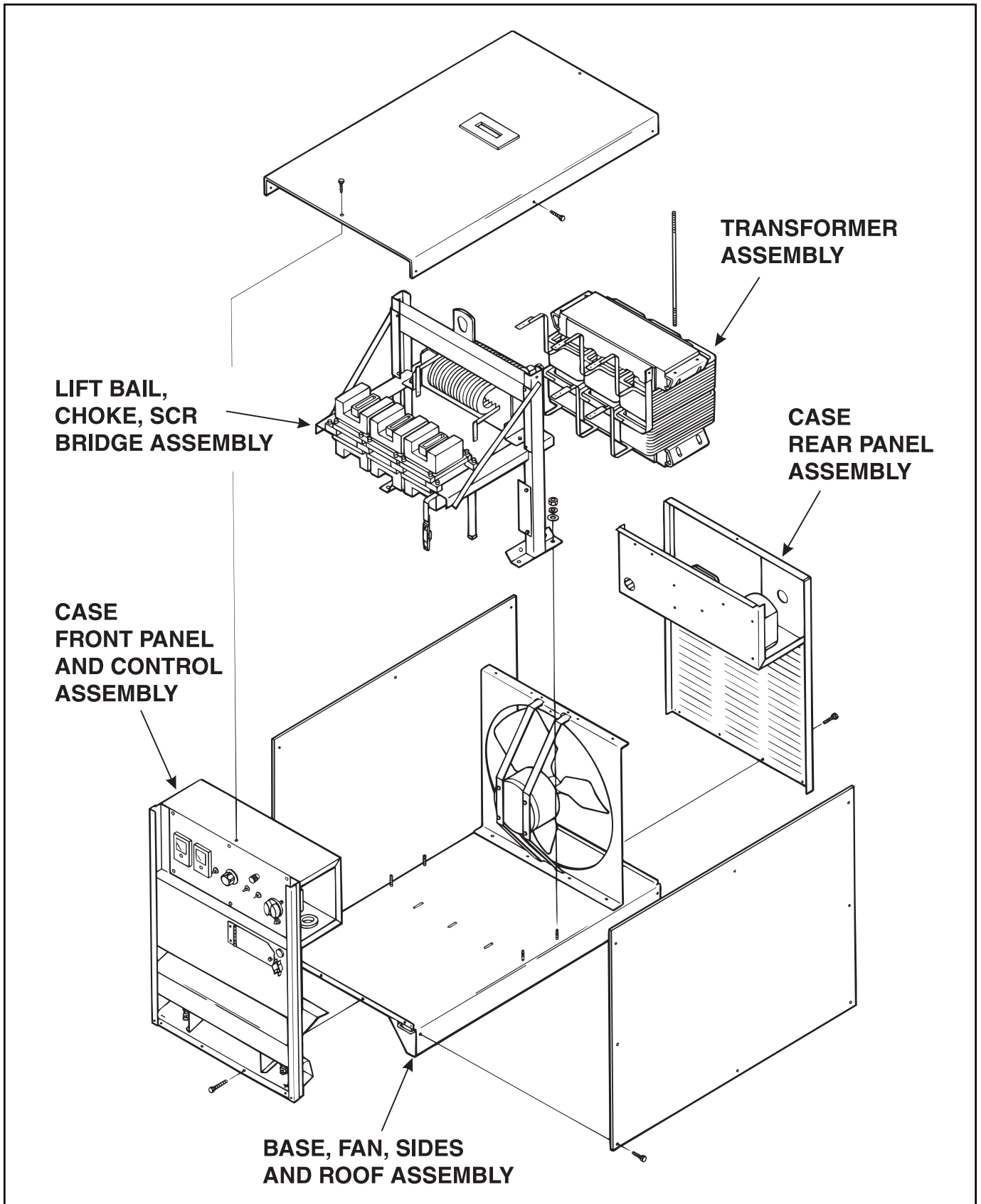

FIGURE D.1 - General Assembly Exploded View

IDEALARC DC-600



## HOW TO USE TROUBLESHOOTING GUIDE

### WARNING

Service and Repair should only be performed by Lincoln Electric Factory Trained Personnel. Unauthorized repairs performed on this equipment may result in danger to the technician and machine operator and will invalidate your factory warranty. For your safety and to avoid Electrical Shock, please observe all safety notes and precautions detailed throughout this manual.

This Troubleshooting Guide is provided to help you locate and repair possible machine malfunctions. Simply follow the three-step procedure listed below.

**Step 1. LOCATE PROBLEM (SYMPTOM).**

Look under the column labeled “PROBLEM (SYMPTOMS)”. This column describes possible symptoms that the machine may exhibit. Find the listing that best describes the symptom that the machine is exhibiting.

**Step 2. POSSIBLE CAUSE.**

The second column labeled “POSSIBLE CAUSE” lists the obvious external possibilities that may contribute to the machine symptom.

**Step 3. RECOMMENDED COURSE OF ACTION**

This column provides a course of action for the Possible Cause, generally it states to contact you local Lincoln Authorized Field Service Facility.

If you do not understand or are unable to perform the Recommended Course of Action safely, contact you local Lincoln Authorized Field Service Facility.

### CAUTION

If for any reason you do not understand the test procedures or are unable to perform the tests/repairs safely, contact your **Local Lincoln Authorized Field Service Facility** for technical troubleshooting assistance before you proceed.

## PC BOARD TROUBLESHOOTING PROCEDURES

**⚠ WARNING****ELECTRIC SHOCK can kill.**

Have an electrician install and service this equipment. Turn the input power OFF at the fuse box before working on equipment. Do not touch electrically hot parts.

**CAUTION:** Sometimes machine failures appear to be due to PC board failures. These problems can sometimes be traced to poor electrical connections. To avoid problems when troubleshooting and replacing PC boards, please use the following procedure:

1. Determine to the best of your technical ability that the PC board is the most likely component causing the failure symptom.
2. Check for loose connections at the PC board to assure that the PC board is properly connected.
3. If the problem persists, replace the suspect PC board using standard practices to avoid static electrical damage and electrical shock. Read the warning inside the static resistant bag and perform the following procedures:

**P.C. Board can be damaged by static electricity.**

- Remove your body's static charge before opening the static-shielding bag. Wear an anti-static wrist strap. For safety, use a 1 Meg ohm resistive cord connected to a grounded part of the equipment frame.

- If you don't have a wrist strap, touch an unpainted,

grounded, part of the equipment frame. Keep touching the frame to prevent static build-up. Be sure not to touch any electrically live parts at the same time.

- Tools which come in contact with the P.C. Board must be either conductive, anti-static or static-dissipative.

- Remove the P.C. Board from the static-shielding bag and place it directly into the equipment. Don't set the P.C. Board on or near paper, plastic or cloth which could have a static charge. If the P.C. Board can't be installed immediately, put it back in the static-shielding bag.

- If the P.C. Board uses protective shorting jumpers, don't remove them until installation is complete.

- If you return a P.C. Board to The Lincoln Electric Company for credit, it must be in the static-shielding bag. This will prevent further damage and allow proper failure analysis.

4. Test the machine to determine if the failure symptom has been corrected by the replacement PC board.

**NOTE:** It is desirable to have a spare (known good) PC board available for PC board troubleshooting.

**NOTE:** Allow the machine to heat up so that all electrical components can reach their operating temperature.

5. Remove the replacement PC board and substitute it with the original PC board to recreate the original problem.

a. If the original problem does not reappear by substituting the original board, then the PC board was not the problem. Continue to look for bad connections in the control wiring harness, junction blocks, and terminal strips.

b. If the original problem is recreated by the substitution of the original board, then the PC board was the problem. Reinstall the replacement PC board and test the machine.

6. Always indicate that this procedure was followed when warranty reports are to be submitted.

**NOTE:** Following this procedure and writing on the warranty report, "INSTALLED AND SWITCHED PC BOARDS TO VERIFY PROBLEM," will help avoid denial of legitimate PC board warranty claims.

Observe Safety Guidelines  
detailed in the beginning of this manual.

## TROUBLESHOOTING GUIDE

PROBLEMS (SYMPTOMS)	POSSIBLE AREAS OF MISADJUSTMENT(S)	RECOMMENDED COURSE OF ACTION
<b>OUTPUT PROBLEMS</b>		
Major Physical or Electrical Damage is Evident	Contact the Lincoln Electric Service Dept. (216) 383-2531 or 1-800- 833-9353 (WELD)	
The Machine is dead- The Input contactor does not operate.	<ol style="list-style-type: none"> <li>1. Check for blown or missing fuses in input lines.</li> <li>2. Check the three- phase input line voltage at the machine. The input voltage must match the rating plate and reconnect panel.</li> </ol>	<p>If all recommended possible areas of misadjustment have been checked and the problem persists, <b>Contact your local Lincoln Authorized Field Service Facility.</b></p>

 **CAUTION**

If for any reason you do not understand the test procedures or are unable to perform the tests/repairs safely, contact your **Local Lincoln Authorized Field Service Facility** for technical troubleshooting assistance before you proceed.

IDEALARC DC-600



## TROUBLESHOOTING GUIDE

Observe Safety Guidelines detailed in the beginning of this manual.

PROBLEMS (SYMPTOMS)	POSSIBLE AREAS OF MISADJUSTMENT(S)	RECOMMENDED COURSE OF ACTION
<b>OUTPUT PROBLEMS</b>		
Input contactor (CR1) chatters.	<ol style="list-style-type: none"> <li>1. The input line voltage may be low. Check all three phases.</li> <li>2. Make sure input line voltage matches machine rating and the reconnect panel is connected correctly for the line voltage.</li> </ol>	<p>If all recommended possible areas of misadjustment have been checked and the problem persists, <b>Contact your local Lincoln Authorized Field Service Facility.</b></p>
Input contactor pulls in when start button is pressed but immediately drops out when start button is released.	<ol style="list-style-type: none"> <li>1. Make sure input line voltage matches machine rating and the reconnect panel is connected correctly for the line voltage.</li> <li>2. Remove all external wires attached to terminal strip. ( 2, 4, 31, 32 75,76,77). If contactor (CR1) functions correctly there may be a "ground" or negative intrusion on the remote control leads (75, 76, or 77). There may also be a "short" at the welder output terminals.</li> <li>3. If the problem persists after performing steps #1 and #2 the problem is in the DC600.</li> </ol>	

**⚠ CAUTION**

If for any reason you do not understand the test procedures or are unable to perform the tests/repairs safely, contact your **Local Lincoln Authorized Field Service Facility** for technical troubleshooting assistance before you proceed.

IDEALARC DC-600



Observe Safety Guidelines  
detailed in the beginning of this manual.

## TROUBLESHOOTING GUIDE

PROBLEMS (SYMPTOMS)	POSSIBLE AREAS OF MISADJUSTMENT(S)	RECOMMENDED COURSE OF ACTION
<b>OUTPUT PROBLEMS</b>		
<p>Machine input contactor operates but machine has no weld output. Fan runs and pilot light glows.</p>	<ol style="list-style-type: none"> <li>1. Install a jumper from #2 to #4 on machine terminal strip. If machine weld output is restored the problem is in the wire feeder or control cable.</li> <li>2. If remote control is not being used make certain the OUTPUT CONTROL SWITCH (SW3) is in the "Panel" position.</li> <li>3. Check 8AMP fuse in the front panel. Replace if blown.</li> <li>4. Check for loose or faulty weld cable connections.</li> </ol>	<p>If all recommended possible areas of misadjustment have been checked and the problem persists, <b>Contact your local Lincoln Authorized Field Service Facility.</b></p>

### CAUTION

If for any reason you do not understand the test procedures or are unable to perform the tests/repairs safely, contact your **Local Lincoln Authorized Field Service Facility** for technical troubleshooting assistance before you proceed.

IDEALARC DC-600



## TROUBLESHOOTING GUIDE

Observe Safety Guidelines detailed in the beginning of this manual.

PROBLEMS (SYMPTOMS)	POSSIBLE AREAS OF MISADJUSTMENT(S)	RECOMMENDED COURSE OF ACTION
<b>OUTPUT PROBLEMS</b>		
Machine has maximum weld output and no control.	<ol style="list-style-type: none"> <li>1. If remote control is being used set OUTPUT CONTROL SWITCH (SW3) in "Panel" position and control weld output with the OUTPUT CONTROL POTENTIOMETER (R1) at DC600. If the problem is solved check the remote control unit (or wire feeder) and associated control cable.</li> </ol>	<p>If all recommended possible areas of misadjustment have been checked and the problem persists, <b>Contact your local Lincoln Authorized Field Service Facility.</b></p>

**⚠ CAUTION**

If for any reason you do not understand the test procedures or are unable to perform the tests/repairs safely, contact your **Local Lincoln Authorized Field Service Facility** for technical troubleshooting assistance before you proceed.

IDEALARC DC-600





Observe Safety Guidelines  
detailed in the beginning of this manual.

## TROUBLESHOOTING GUIDE

PROBLEMS (SYMPTOMS)	POSSIBLE AREAS OF MISADJUSTMENT(S)	RECOMMENDED COURSE OF ACTION
<b>OUTPUT PROBLEMS</b>		
Machine has minimum output and no control.	<ol style="list-style-type: none"> <li>1. If a remote control unit is NOT connected to the terminal strip #75, #76, and #77 terminals, the OUTPUT CONTROL SWITCH must be in the "Panel" position.</li> <li>2. If a remote control cable is connected to terminals #75, #76 and #77 the leads may be "shorted" to the positive weld output.</li> <li>3. Make certain the Three Phase input voltage is correct and matches the machine rating and the reconnect panel.</li> </ol>	<p>If all recommended possible areas of misadjustment have been checked and the problem persists, <b>Contact your local Lincoln Authorized Field Service Facility.</b></p>
The machine does not have maximum weld output.	<ol style="list-style-type: none"> <li>1. Check all Three-Phase input lines at the DC600. Make sure input voltages match machine rating and reconnect panel.</li> <li>2. Put OUTPUT CONTROL SWITCH (SW3) in "Panel" position. If problem is solved then check remote control unit or wire feeder.</li> </ol>	

### CAUTION

If for any reason you do not understand the test procedures or are unable to perform the tests/repairs safely, contact your **Local Lincoln Authorized Field Service Facility** for technical troubleshooting assistance before you proceed.

IDEALARC DC-600



## TROUBLESHOOTING GUIDE

Observe Safety Guidelines detailed in the beginning of this manual.

PROBLEMS (SYMPTOMS)	POSSIBLE AREAS OF MISADJUSTMENT(S)	RECOMMENDED COURSE OF ACTION
<b>OUTPUT PROBLEMS</b>		
<p>Machine shuts off (input contactor drops out) when the welder output terminals are made electrically "hot". (#2 to #4 closure at terminal strip.)</p>	<ol style="list-style-type: none"> <li>1. Remove all welding cables and control cables from the DC 600. Jumper #2 to #4 at the terminal strip. If the machine does NOT shut off and normal open circuit voltage is present at the welder output terminals the problem is external to the DC600. Either the remote leads #75, #76 or #77 are grounded to the negative output cable or there is a short on the welding output terminals.</li> <li>2. If the machine still shuts off when all control and welding cables are removed then the problem is internal to the DC600.</li> </ol>	<p>If all recommended possible areas of misadjustment have been checked and the problem persists, <b>Contact your local Lincoln Authorized Field Service Facility.</b></p>
<p>The DC600 will NOT shut off when the Stop button is pushed.</p>	<ol style="list-style-type: none"> <li>1. Contact your local Lincoln Authorized Field Service Facility.</li> </ol>	

**⚠ CAUTION**

If for any reason you do not understand the test procedures or are unable to perform the tests/repairs safely, contact your **Local Lincoln Authorized Field Service Facility** for technical troubleshooting assistance before you proceed.

IDEALARC DC-600



Observe Safety Guidelines  
detailed in the beginning of this manual.

## TROUBLESHOOTING GUIDE

PROBLEMS (SYMPTOMS)	POSSIBLE AREAS OF MISADJUSTMENT(S)	RECOMMENDED COURSE OF ACTION
<b>OUTPUT PROBLEMS</b>		
<p>The weld output terminals are always electrically "hot".</p>	<ol style="list-style-type: none"> <li>1. Remove any external leads hooked to #2 and #4 on the terminal strip. If the problem disappears the fault is in the control cable or wire feeder.</li> <li>2. If some open circuit voltage is present (over 3VDC.) after performing Step #1. then the problem is within the DC600.</li> </ol>	<p>If all recommended possible areas of misadjustment have been checked and the problem persists, <b>Contact your local Lincoln Authorized Field Service Facility.</b></p>

### CAUTION

If for any reason you do not understand the test procedures or are unable to perform the tests/repairs safely, contact your **Local Lincoln Authorized Field Service Facility** for technical troubleshooting assistance before you proceed.

IDEALARC DC-600



## TROUBLESHOOTING GUIDE

Observe Safety Guidelines  
detailed in the beginning of this manual.

PROBLEMS (SYMPTOMS)	POSSIBLE AREAS OF MISADJUSTMENT(S)	RECOMMENDED COURSE OF ACTION
<b>WELDING PROBLEMS</b>		
<p>Poor arc starting when the DC600 is in the CV Sub-Arc or CV Innershield Modes.</p>	<ol style="list-style-type: none"> <li>1. Make sure the proper welding procedures are being used. (wire feed speed , arc voltage and wire size)</li> <li>2. Check weld cables for loose or faulty connections.</li> </ol>	<p>If all recommended possible areas of misadjustment have been checked and the problem persists, <b>Contact your local Lincoln Authorized Field Service Facility.</b></p>

 **CAUTION**

If for any reason you do not understand the test procedures or are unable to perform the tests/repairs safely, contact your **Local Lincoln Authorized Field Service Facility** for technical troubleshooting assistance before you proceed.

IDEALARC DC-600



Observe Safety Guidelines  
detailed in the beginning of this manual.

## TROUBLESHOOTING GUIDE

PROBLEMS (SYMPTOMS)	POSSIBLE AREAS OF MISADJUSTMENT(S)	RECOMMENDED COURSE OF ACTION
<b>WELDING PROBLEMS</b>		
<p>Poor arc characteristics in all processes.</p>	<ol style="list-style-type: none"> <li>1. Check for the correct input voltages on the three- phase input lines at the DC600.</li> <li>2. Make sure the proper welding procedures are being used.(wire feed speed, arc voltage and wire size).</li> <li>3. Check the welding cables for loose or faulty connections.</li> </ol>	<p>If all recommended possible areas of misadjustment have been checked and the problem persists, <b>Contact your local Lincoln Authorized Field Service Facility.</b></p>

### CAUTION

If for any reason you do not understand the test procedures or are unable to perform the tests/repairs safely, contact your **Local Lincoln Authorized Field Service Facility** for technical troubleshooting assistance before you proceed.

IDEALARC DC-600



WIRING DIAGRAM (Various Single, Dual and Triple Voltage Machines)

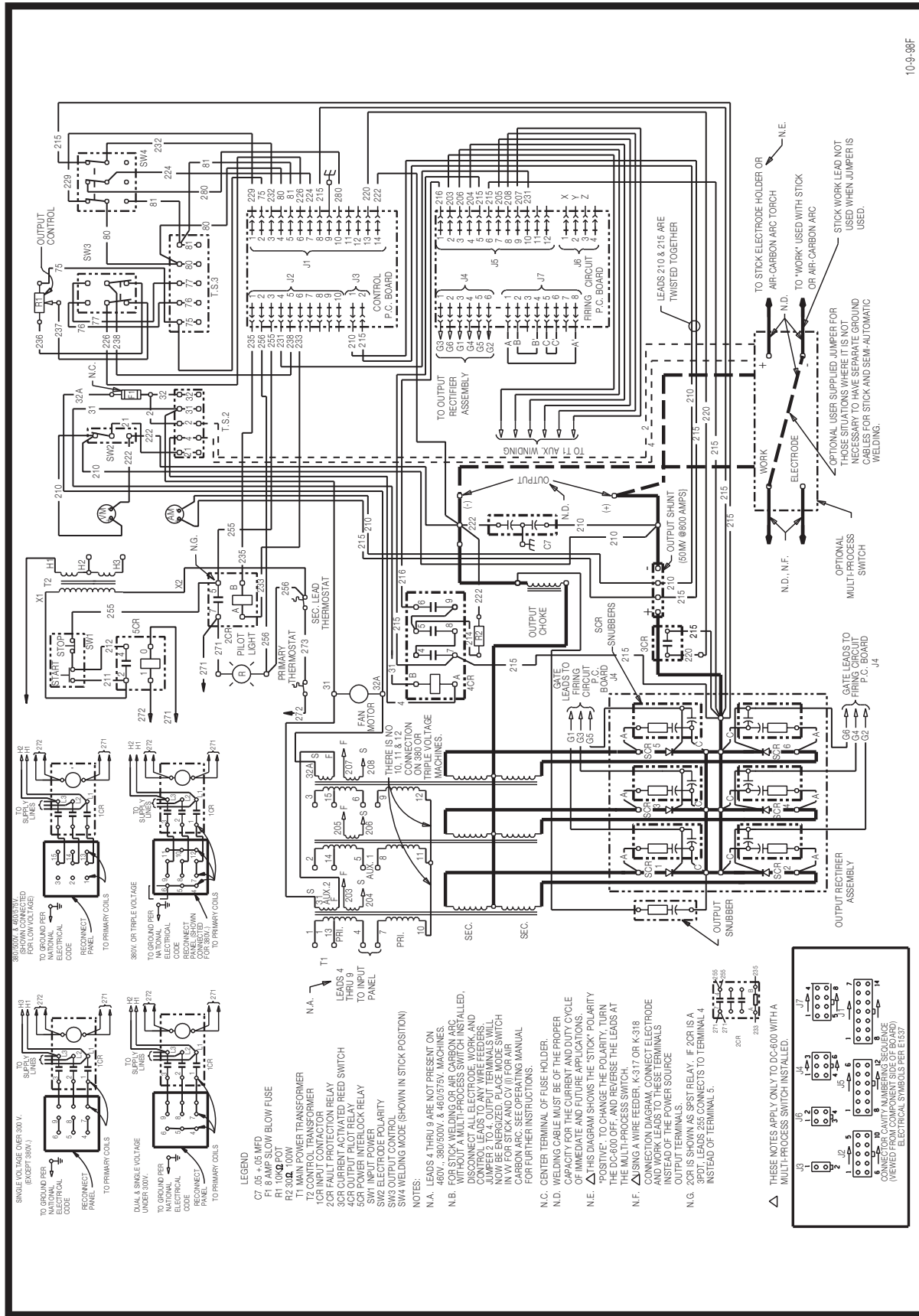

10-9-98F

L10675

NOTE: This diagram is for reference only. It may not be accurate for all machines covered by this manual. The specific diagram for a particular code is pasted inside the machine on one of the enclosure panels. If the diagram is illegible, write to the Service Department for a replacement. Give the equipment code number.

IDEALARC DC-600



WIRING DIAGRAM (Single Voltage 440 & 460)

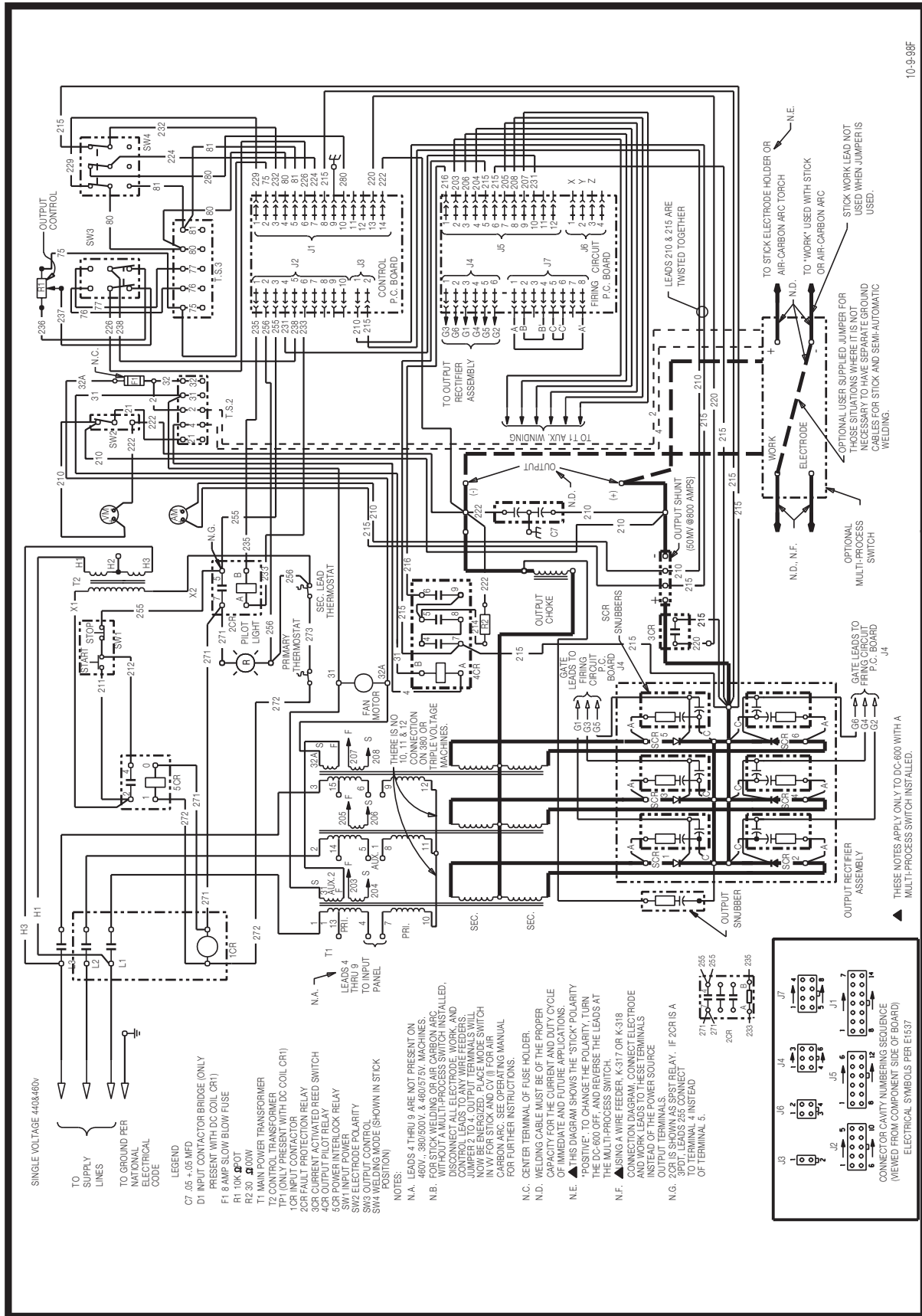

SINGLE VOLTAGE 440X460V

TO SUPPLY LINES

TO GROUND PER NATIONAL ELECTRICAL CODE

LEGEND

C7 .05 + .05 MFD

D1 INPUT CONTACTOR BRIDGE (ONLY PRESENT WITH DC COIL CR1)

F1 8 AMP SLOW BLOW FUSE

R1 10K Ω POT

R2 30 Ω POT

T1 MAIN POWER TRANSFORMER

T2 CONTROL TRANSFORMER

TCR THERMOSTAT

1CR INPUT CONTACTOR

2CR CURRENT ACTIVATED REED SWITCH

3CR CURRENT ACTIVATED REED SWITCH

5CR POWER INTERLOCK RELAY

SW1 INPUT POWER

SW2 ELECTRODE POLARITY

SW3 OUTPUT CONTROL

SW4 WELDING MODE (SHOWN IN STICK POSITION)

NOTES:

N.A. LEADS 4 THRU 9 ARE NOT PRESENT ON 440V, 380/200V, & 460/575V MACHINES.

N.B. FOR STICK WELDING OR AIR CARBON ARC DISCONNECT ALL ELECTRODE, WORK, AND JUMPER 2 TO ALL OUTPUT TERMINALS. ALL NOW BE ENERGIZED. PLACE MODE SWITCH IN W FOR STICK AND CV (I) FOR AIR CARBON ARC. SEE OPERATING MANUAL FOR FURTHER INSTRUCTIONS.

N.C. CENTER TERMINAL OF FUSE HOLDER.

N.D. WELDING CABLE MUST BE OF THE PROPER CAPACITY FOR THE CURRENT AND DUTY CYCLE OF IMMEDIATE AND FUTURE APPLICATIONS.

N.E. ▲ THIS DIAGRAM SHOWS THE 'STICK' POLARITY 'POSITIVE'. TO CHANGE THE POLARITY, TURN THE DC-600 POWER PACK TO REVERSE THE LEADS AT THE DC-600 POWER PACK.

N.F. ▲ USING A WIRE FEEDER, K-317 OR K-318 CONNECTION DIAGRAM, CONNECT ELECTRODE AND WORK LEADS TO THESE TERMINALS INSTEAD OF THE POWER SOURCE OUTPUT TERMINALS.

N.G. ZCR IS SHOWN AS SPST RELAY. IF ZCR IS A SPDT RELAY, CONNECT THE COMMON TERMINAL TO TERMINAL 4 INSTEAD OF TERMINAL 5.

▲ THESE NOTES APPLY ONLY TO DC-600 WITH A MULTI-PROCESS SWITCH INSTALLED.

TO OUTPUT RECTIFIER ASSEMBLY

TO OUTPUT CHOKER

TO OUTPUT SNUBBERS

TO OUTPUT

TO STICK ELECTRODE HOLDER OR AIR-CARBON ARC TORCH

TO 'WORK' USED WITH STICK OR AIR-CARBON ARC

STICK WORK LEAD NOT USED WHEN JUMPER IS USED.

OPTIONAL USER SUPPLIED JUMPER FOR THOSE SITUATIONS (IS) WHERE SEPARATE CABLES FOR STICK AND SEMI-AUTOMATIC WELDING.

OPTIONAL MULTI-PROCESS SWITCH

OPTIONAL DC-600 POWER PACK

TO DC-600 POWER PACK

TO GATE LEADS TO P.C. BOARD

TO AUXILIARY WINDING

TO FIRING CIRCUIT P.C. BOARD

LEADS 210 & 215 ARE TWISTED TOGETHER

TO OUTPUT RECTIFIER ASSEMBLY

TO OUTPUT CHOKER

TO OUTPUT SNUBBERS

TO OUTPUT

TO STICK ELECTRODE HOLDER OR AIR-CARBON ARC TORCH

TO 'WORK' USED WITH STICK OR AIR-CARBON ARC

STICK WORK LEAD NOT USED WHEN JUMPER IS USED.

OPTIONAL USER SUPPLIED JUMPER FOR THOSE SITUATIONS (IS) WHERE SEPARATE CABLES FOR STICK AND SEMI-AUTOMATIC WELDING.

OPTIONAL MULTI-PROCESS SWITCH

OPTIONAL DC-600 POWER PACK

TO DC-600 POWER PACK

TO GATE LEADS TO P.C. BOARD

TO AUXILIARY WINDING

TO FIRING CIRCUIT P.C. BOARD

LEADS 210 & 215 ARE TWISTED TOGETHER

TO OUTPUT RECTIFIER ASSEMBLY

TO OUTPUT CHOKER

TO OUTPUT SNUBBERS

TO OUTPUT

TO STICK ELECTRODE HOLDER OR AIR-CARBON ARC TORCH

TO 'WORK' USED WITH STICK OR AIR-CARBON ARC

STICK WORK LEAD NOT USED WHEN JUMPER IS USED.

OPTIONAL USER SUPPLIED JUMPER FOR THOSE SITUATIONS (IS) WHERE SEPARATE CABLES FOR STICK AND SEMI-AUTOMATIC WELDING.

OPTIONAL MULTI-PROCESS SWITCH

OPTIONAL DC-600 POWER PACK

TO DC-600 POWER PACK

TO GATE LEADS TO P.C. BOARD

TO AUXILIARY WINDING

TO FIRING CIRCUIT P.C. BOARD

LEADS 210 & 215 ARE TWISTED TOGETHER

TO OUTPUT RECTIFIER ASSEMBLY

TO OUTPUT CHOKER

TO OUTPUT SNUBBERS

TO OUTPUT

TO STICK ELECTRODE HOLDER OR AIR-CARBON ARC TORCH

TO 'WORK' USED WITH STICK OR AIR-CARBON ARC

STICK WORK LEAD NOT USED WHEN JUMPER IS USED.

OPTIONAL USER SUPPLIED JUMPER FOR THOSE SITUATIONS (IS) WHERE SEPARATE CABLES FOR STICK AND SEMI-AUTOMATIC WELDING.

OPTIONAL MULTI-PROCESS SWITCH

OPTIONAL DC-600 POWER PACK

TO DC-600 POWER PACK

TO GATE LEADS TO P.C. BOARD

TO AUXILIARY WINDING

TO FIRING CIRCUIT P.C. BOARD

LEADS 210 & 215 ARE TWISTED TOGETHER

TO OUTPUT RECTIFIER ASSEMBLY

TO OUTPUT CHOKER

TO OUTPUT SNUBBERS

TO OUTPUT

TO STICK ELECTRODE HOLDER OR AIR-CARBON ARC TORCH

TO 'WORK' USED WITH STICK OR AIR-CARBON ARC

STICK WORK LEAD NOT USED WHEN JUMPER IS USED.

OPTIONAL USER SUPPLIED JUMPER FOR THOSE SITUATIONS (IS) WHERE SEPARATE CABLES FOR STICK AND SEMI-AUTOMATIC WELDING.

OPTIONAL MULTI-PROCESS SWITCH

OPTIONAL DC-600 POWER PACK

TO DC-600 POWER PACK

TO GATE LEADS TO P.C. BOARD

TO AUXILIARY WINDING

TO FIRING CIRCUIT P.C. BOARD

LEADS 210 & 215 ARE TWISTED TOGETHER

TO OUTPUT RECTIFIER ASSEMBLY

TO OUTPUT CHOKER

TO OUTPUT SNUBBERS

TO OUTPUT

TO STICK ELECTRODE HOLDER OR AIR-CARBON ARC TORCH

TO 'WORK' USED WITH STICK OR AIR-CARBON ARC

STICK WORK LEAD NOT USED WHEN JUMPER IS USED.

OPTIONAL USER SUPPLIED JUMPER FOR THOSE SITUATIONS (IS) WHERE SEPARATE CABLES FOR STICK AND SEMI-AUTOMATIC WELDING.

OPTIONAL MULTI-PROCESS SWITCH

OPTIONAL DC-600 POWER PACK

TO DC-600 POWER PACK

TO GATE LEADS TO P.C. BOARD

TO AUXILIARY WINDING

TO FIRING CIRCUIT P.C. BOARD

LEADS 210 & 215 ARE TWISTED TOGETHER

TO OUTPUT RECTIFIER ASSEMBLY

TO OUTPUT CHOKER

TO OUTPUT SNUBBERS

TO OUTPUT

TO STICK ELECTRODE HOLDER OR AIR-CARBON ARC TORCH

TO 'WORK' USED WITH STICK OR AIR-CARBON ARC

STICK WORK LEAD NOT USED WHEN JUMPER IS USED.

OPTIONAL USER SUPPLIED JUMPER FOR THOSE SITUATIONS (IS) WHERE SEPARATE CABLES FOR STICK AND SEMI-AUTOMATIC WELDING.

OPTIONAL MULTI-PROCESS SWITCH

OPTIONAL DC-600 POWER PACK

TO DC-600 POWER PACK

TO GATE LEADS TO P.C. BOARD

TO AUXILIARY WINDING

TO FIRING CIRCUIT P.C. BOARD

LEADS 210 & 215 ARE TWISTED TOGETHER

TO OUTPUT RECTIFIER ASSEMBLY

TO OUTPUT CHOKER

TO OUTPUT SNUBBERS

TO OUTPUT

TO STICK ELECTRODE HOLDER OR AIR-CARBON ARC TORCH

TO 'WORK' USED WITH STICK OR AIR-CARBON ARC

STICK WORK LEAD NOT USED WHEN JUMPER IS USED.

OPTIONAL USER SUPPLIED JUMPER FOR THOSE SITUATIONS (IS) WHERE SEPARATE CABLES FOR STICK AND SEMI-AUTOMATIC WELDING.

OPTIONAL MULTI-PROCESS SWITCH

OPTIONAL DC-600 POWER PACK

TO DC-600 POWER PACK

TO GATE LEADS TO P.C. BOARD

TO AUXILIARY WINDING

TO FIRING CIRCUIT P.C. BOARD

LEADS 210 & 215 ARE TWISTED TOGETHER

NOTE: This diagram is for reference only. It may not be accurate for all machines covered by this manual. The specific diagram for a particular code is pasted inside the machine on one of the enclosure panels. If the diagram is illegible, write to the Service Department for a replacement. Give the equipment code number.

10-9-98E

L10576

IDEALARC DC-600



WIRING DIAGRAM (230/460/575)

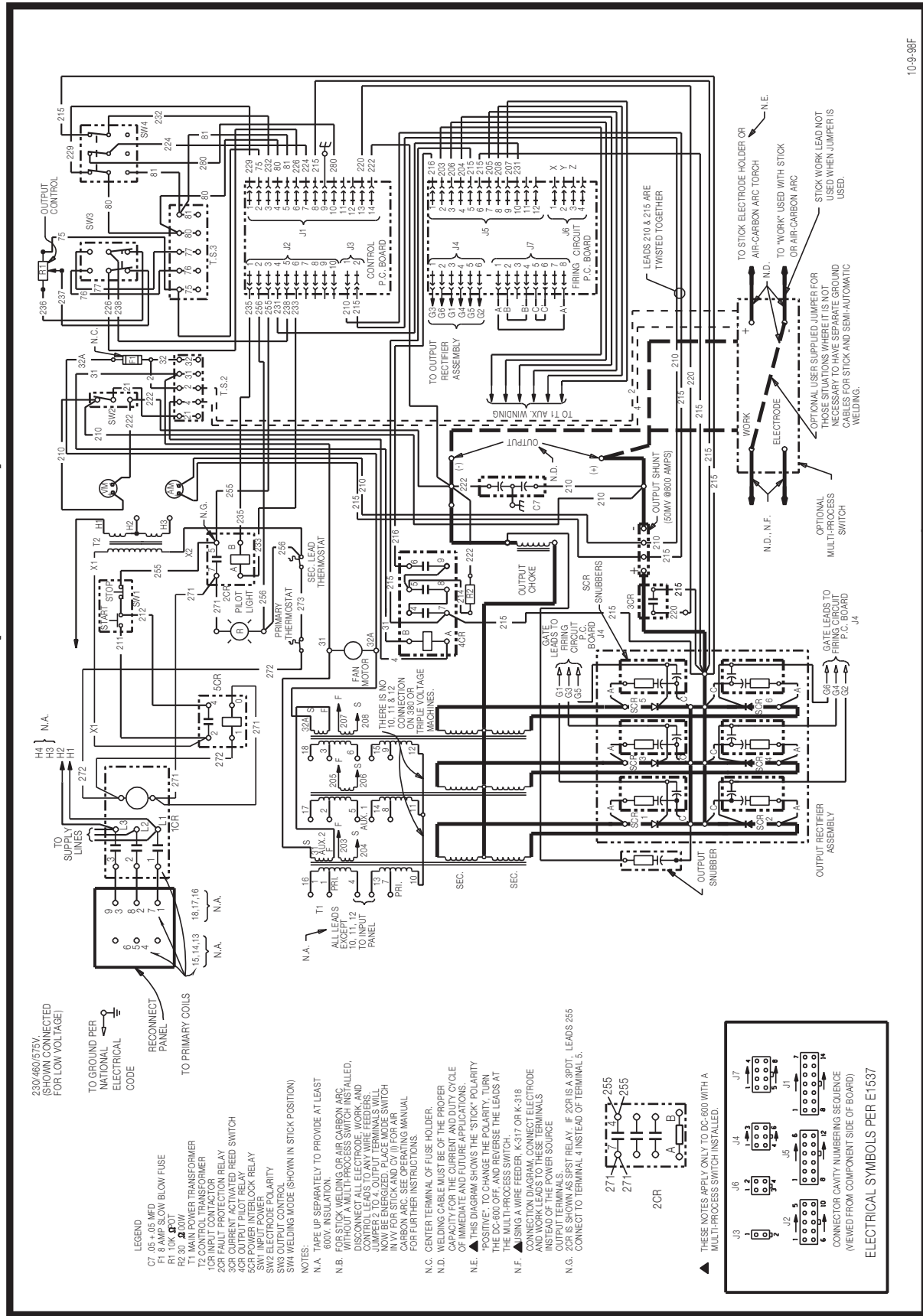

10-9-98F  
L10577

NOTE: This diagram is for reference only. It may not be accurate for all machines covered by this manual. The specific diagram for a particular code is pasted inside the machine on one of the enclosure panels. If the diagram is illegible, write to the Service Department for a replacement. Give the equipment code number.

IDEALARC DC-600





# NOTES

---

IDEALARC DC-600



# NOTES

---

IDEALARC DC-600





<b>WARNING</b>	<ul style="list-style-type: none"> <li>● Do not touch electrically live parts or electrode with skin or wet clothing.</li> <li>● Insulate yourself from work and ground.</li> </ul>	<ul style="list-style-type: none"> <li>● Keep flammable materials away.</li> </ul>	<ul style="list-style-type: none"> <li>● Wear eye, ear and body protection.</li> </ul>
Spanish <b>AVISO DE PRECAUCION</b>	<ul style="list-style-type: none"> <li>● No toque las partes o los electrodos bajo carga con la piel o ropa mojada.</li> <li>● Aíslese del trabajo y de la tierra.</li> </ul>	<ul style="list-style-type: none"> <li>● Mantenga el material combustible fuera del área de trabajo.</li> </ul>	<ul style="list-style-type: none"> <li>● Protéjase los ojos, los oídos y el cuerpo.</li> </ul>
French <b>ATTENTION</b>	<ul style="list-style-type: none"> <li>● Ne laissez ni la peau ni des vêtements mouillés entrer en contact avec des pièces sous tension.</li> <li>● Isolez-vous du travail et de la terre.</li> </ul>	<ul style="list-style-type: none"> <li>● Gardez à l'écart de tout matériel inflammable.</li> </ul>	<ul style="list-style-type: none"> <li>● Protégez vos yeux, vos oreilles et votre corps.</li> </ul>
German <b>WARNUNG</b>	<ul style="list-style-type: none"> <li>● Berühren Sie keine stromführenden Teile oder Elektroden mit Ihrem Körper oder feuchter Kleidung!</li> <li>● Isolieren Sie sich von den Elektroden und dem Erdboden!</li> </ul>	<ul style="list-style-type: none"> <li>● Entfernen Sie brennbares Material!</li> </ul>	<ul style="list-style-type: none"> <li>● Tragen Sie Augen-, Ohren- und Körperschutz!</li> </ul>
Portuguese <b>ATENÇÃO</b>	<ul style="list-style-type: none"> <li>● Não toque partes elétricas e electrodos com a pele ou roupa molhada.</li> <li>● Isole-se da peça e terra.</li> </ul>	<ul style="list-style-type: none"> <li>● Mantenha inflamáveis bem guardados.</li> </ul>	<ul style="list-style-type: none"> <li>● Use proteção para a vista, ouvido e corpo.</li> </ul>
Japanese <b>注意事項</b>	<ul style="list-style-type: none"> <li>● 通電中の電気部品、又は溶材にヒフやぬれた布で触れないこと。</li> <li>● 施工物やアースから身体が絶縁されている様にして下さい。</li> </ul>	<ul style="list-style-type: none"> <li>● 燃えやすいものの側での溶接作業は絶対にしてはなりません。</li> </ul>	<ul style="list-style-type: none"> <li>● 目、耳及び身体に保護具をして下さい。</li> </ul>
Chinese <b>警告</b>	<ul style="list-style-type: none"> <li>● 皮膚或濕衣物切勿接觸帶電部件及鎢條。</li> <li>● 使你自已與地面和工件絕緣。</li> </ul>	<ul style="list-style-type: none"> <li>● 把一切易燃物品移離工作場所。</li> </ul>	<ul style="list-style-type: none"> <li>● 佩戴眼、耳及身體勞動保護用具。</li> </ul>
Korean <b>위험</b>	<ul style="list-style-type: none"> <li>● 전도체나 용접봉을 젖은 형갑 또는 피부로 절대 접촉치 마십시오.</li> <li>● 모재와 접지를 접촉치 마십시오.</li> </ul>	<ul style="list-style-type: none"> <li>● 인화성 물질을 접근시키지 마십시오.</li> </ul>	<ul style="list-style-type: none"> <li>● 눈, 귀와 몸에 보호장구를 착용하십시오.</li> </ul>
Arabic <b>تحذير</b>	<ul style="list-style-type: none"> <li>● لا تلمس الاجزاء التي يسري فيها التيار الكهربائي أو الألكترود بجسدك أو بالملابس المبللة بالماء.</li> <li>● ضع عازلا على جسمك خلال العمل.</li> </ul>	<ul style="list-style-type: none"> <li>● ضع المواد القابلة للاشتعال في مكان بعيد.</li> </ul>	<ul style="list-style-type: none"> <li>● ضع أدوات وملابس واقية على عينيك وأذنيك وجسمك.</li> </ul>

READ AND UNDERSTAND THE MANUFACTURER'S INSTRUCTION FOR THIS EQUIPMENT AND THE CONSUMABLES TO BE USED AND FOLLOW YOUR EMPLOYER'S SAFETY PRACTICES.

SE RECOMIENDA LEER Y ENTENDER LAS INSTRUCCIONES DEL FABRICANTE PARA EL USO DE ESTE EQUIPO Y LOS CONSUMIBLES QUE VA A UTILIZAR, SIGA LAS MEDIDAS DE SEGURIDAD DE SU SUPERVISOR.

LISEZ ET COMPRENEZ LES INSTRUCTIONS DU FABRICANT EN CE QUI REGARDE CET EQUIPMENT ET LES PRODUITS A ETRE EMPLOYES ET SUIVEZ LES PROCEDURES DE SECURITE DE VOTRE EMPLOYEUR.

LESEN SIE UND BEFOLGEN SIE DIE BETRIEBSANLEITUNG DER ANLAGE UND DEN ELEKTRODENEINSATZ DES HERSTELLERS. DIE UNFALLVERHÜTUNGSVORSCHRIFTEN DES ARBEITGEBERS SIND EBENFALLS ZU BEACHTEN.

			
<ul style="list-style-type: none"> <li>● Keep your head out of fumes.</li> <li>● Use ventilation or exhaust to remove fumes from breathing zone.</li> </ul>	<ul style="list-style-type: none"> <li>● Turn power off before servicing.</li> </ul>	<ul style="list-style-type: none"> <li>● Do not operate with panel open or guards off.</li> </ul>	<b>WARNING</b>
<ul style="list-style-type: none"> <li>● Los humos fuera de la zona de respiración.</li> <li>● Mantenga la cabeza fuera de los humos. Utilice ventilación o aspiración para gases.</li> </ul>	<ul style="list-style-type: none"> <li>● Desconectar el cable de alimentación de poder de la máquina antes de iniciar cualquier servicio.</li> </ul>	<ul style="list-style-type: none"> <li>● No operar con panel abierto o guardas quitadas.</li> </ul>	Spanish <b>AVISO DE PRECAUCION</b>
<ul style="list-style-type: none"> <li>● Gardez la tête à l'écart des fumées.</li> <li>● Utilisez un ventilateur ou un aspirateur pour ôter les fumées des zones de travail.</li> </ul>	<ul style="list-style-type: none"> <li>● Débranchez le courant avant l'entretien.</li> </ul>	<ul style="list-style-type: none"> <li>● N'opérez pas avec les panneaux ouverts ou avec les dispositifs de protection enlevés.</li> </ul>	French <b>ATTENTION</b>
<ul style="list-style-type: none"> <li>● Vermeiden Sie das Einatmen von Schweißrauch!</li> <li>● Sorgen Sie für gute Be- und Entlüftung des Arbeitsplatzes!</li> </ul>	<ul style="list-style-type: none"> <li>● Strom vor Wartungsarbeiten abschalten! (Netzstrom völlig öffnen; Maschine anhalten!)</li> </ul>	<ul style="list-style-type: none"> <li>● Anlage nie ohne Schutzgehäuse oder Innenschutzverkleidung in Betrieb setzen!</li> </ul>	German <b>WARNUNG</b>
<ul style="list-style-type: none"> <li>● Mantenha seu rosto da fumaça.</li> <li>● Use ventilação e exaustão para remover fumo da zona respiratória.</li> </ul>	<ul style="list-style-type: none"> <li>● Não opere com as tampas removidas.</li> <li>● Desligue a corrente antes de fazer serviço.</li> <li>● Não toque as partes elétricas nuas.</li> </ul>	<ul style="list-style-type: none"> <li>● Mantenha-se afastado das partes moventes.</li> <li>● Não opere com os painéis abertos ou guardas removidas.</li> </ul>	Portuguese <b>ATENÇÃO</b>
<ul style="list-style-type: none"> <li>● ヒュームから頭を離すようにして下さい。</li> <li>● 換気や排煙に十分留意して下さい。</li> </ul>	<ul style="list-style-type: none"> <li>● メンテナンス・サービスに取りかかる際には、まず電源スイッチを必ず切って下さい。</li> </ul>	<ul style="list-style-type: none"> <li>● パネルやカバーを取り外したままで機械操作をしないで下さい。</li> </ul>	Japanese <b>注意事項</b>
<ul style="list-style-type: none"> <li>● 頭部遠離煙霧。</li> <li>● 在呼吸區使用通風或排風器除煙。</li> </ul>	<ul style="list-style-type: none"> <li>● 維修前切斷電源。</li> </ul>	<ul style="list-style-type: none"> <li>● 儀表板打開或沒有安全罩時不準作業。</li> </ul>	Chinese <b>警告</b>
<ul style="list-style-type: none"> <li>● 얼굴로부터 용접가스를 멀리하십시오.</li> <li>● 호흡지역으로부터 용접가스를 제거하기 위해 가스제거기나 통풍기를 사용하십시오.</li> </ul>	<ul style="list-style-type: none"> <li>● 보수전에 전원을 차단하십시오.</li> </ul>	<ul style="list-style-type: none"> <li>● 판넬이 열린 상태로 작동치 마십시오.</li> </ul>	Korean <b>위험</b>
<ul style="list-style-type: none"> <li>● ابعد رأسك بعيداً عن الدخان.</li> <li>● استعمل التهوية أو جهاز ضغط الدخان للخارج لكي تبعد الدخان عن المنطقة التي تتنفس فيها.</li> </ul>	<ul style="list-style-type: none"> <li>● أقطع التيار الكهربائي قبل القيام بأية صيانة.</li> </ul>	<ul style="list-style-type: none"> <li>● لا تشغيل هذا الجهاز اذا كانت الاغطية الحديدية الواقية ليست عليه.</li> </ul>	Arabic <b>تحذير</b>

LEIA E COMPREENDA AS INSTRUÇÕES DO FABRICANTE PARA ESTE EQUIPAMENTO E AS PARTES DE USO, E SIGA AS PRÁTICAS DE SEGURANÇA DO EMPREGADOR.

使う機械や溶材のメーカーの指示書をよく読み、まず理解して下さい。そして貴社の安全規定に従って下さい。

請詳細閱讀並理解製造廠提供的說明以及應該使用的銀焊材料，並請遵守貴方的有閣勞動保護規定。

이 제품에 동봉된 작업지침서를 숙지하시고 귀사의 작업자 안전수칙을 준수하시기 바랍니다.

اقرأ بتمعن وافهم تعليمات المصنع المنتج لهذه المعدات والمواد قبل استعمالها واتبع تعليمات الوقاية لصاحب العمل.

# LIMITED WARRANTY

## STATEMENT OF LIMITED WARRANTY

The Lincoln Electric Company (Lincoln) warrants to the end user (purchaser) of all new welding and cutting equipment, electrode and flux (collectively called the "Goods") that it will be free of defects in workmanship and material.

This warranty is void if Lincoln or its Authorized Service Facility finds that the equipment has been subjected to improper installation, improper care or abnormal operations.

## WARRANTY PERIOD <sup>(1)</sup> <sup>(2)</sup> <sup>(3)</sup>

Lincoln will assume both the parts and labor expense of correcting defects during the full warranty period. All warranty periods date from the date of purchase to the original end user or from the date of manufacture if the original invoice cannot be provided and are as follows:

### 7 Years

- Main power rectifiers on all non-inverter low frequency (50 and 60 Hz) type welders.

### 3 Years

- All Lincoln welding machines, wirefeeders and plasma cutting machines unless listed below.

### 2 Years

- Power Arc 4000, Power Arc 5000  
Weldanpower 125

### 1 Year

- AC-100  
Invertec V100-S, Invertec V130-S, Invertec V200-T  
Pro-Cut 25, Handy MIG 101, Handy Core 100
- All water coolers (internal or external models)
- All stick electrode, welding wire and flux.
- Arc welding and cutting robots and robotic controllers
- All Environmental Systems equipment, including portable units, central units and accessories. (Does not include consumable items listed under 30 day warranty.)
- All welding and cutting accessories including wire feed modules, undercarriages, field installed options that are sold separately, unattached options, welding supplies, standard accessory sets, replacement parts, and Magnum products. (Does not include expendable parts and guns/torches listed under 90 and 30 day warranties)

### 90 Days

- All gun and cable assemblies, TIG and plasma torches and spool guns.

### 30 Days

- All consumable items that may be used with the environmental systems described above. This includes hoses, filters, belts and hose adapters.
- Expendable Parts - Lincoln is not responsible for the replacement of any expendable part that is required due to normal wear.

## CONDITIONS OF WARRANTY

### TO OBTAIN WARRANTY COVERAGE:

The purchaser must contact Lincoln or Lincoln's Authorized Service Facility about any defect claimed under Lincoln's warranty.

Determination of warranty on welding and cutting equipment will be made by Lincoln or Lincoln's Authorized Service Facility.

### WARRANTY REPAIR:

If Lincoln or Lincoln's Authorized Service Facility confirms the existence of a defect covered by this warranty, the defect will be corrected by repair or replacement at Lincoln's option.

At Lincoln's request, the purchaser must return, to Lincoln or its Authorized Service Facility, any "Goods" claimed defective under Lincoln's warranty.

### FREIGHT COSTS:

The purchaser is responsible for shipment to and from the Lincoln Authorized Service Facility.

### WARRANTY LIMITATIONS

Lincoln will not accept responsibility or liability for repairs made outside of a Lincoln Authorized Service Facility.

Lincoln's liability under this warranty shall not exceed the cost of correcting the defect of the Lincoln product.

Lincoln will not be liable for incidental or consequential damages (such as loss of business, etc.) caused by the defect or the time involved to correct the defect.

This written warranty is the only express warranty provided by Lincoln with respect to its products. Warranties implied by law such as the warranty of merchantability are limited to the duration of this limited warranty for the equipment involved.

This warranty gives the purchaser specific legal rights. The purchaser may also have other rights which vary from state to state.

<sup>(1)</sup> Equipment manufactured for the Lincoln Electric Company is subject to the warranty period of the original manufacturer.

<sup>(2)</sup> All engines and engine accessories are warranted by the engine or engine accessory manufacturer and are not covered by this warranty.

<sup>(3)</sup> SAE400 WELD N' AIR compressor is warranted by the compressor manufacturer and not covered by this warranty.



March, '99

World's Leader in Welding and Cutting Products

Premier Manufacturer of Industrial Motors

• Sales and Service through Subsidiaries and Distributors Worldwide •

Cleveland, Ohio 44117-1199 U.S.A. TEL: 216.481.8100 FAX: 216.486.1751 WEB SITE: www.lincolnelectric.com