

# Robotic blast finishing

automated blast finishing

## Guyson robotically controlled blasting and shot peening



# The case for robotically controlled blasting and peening

## Removal of hand processing variations

Guyson have been successfully selling manual blast cabinets for the surface treatment of components since way back in 1938. Manual blast cabinets provide a cost effective and flexible solution to providing a surface finish on a varied mix of component sizes and shapes. Similarly the human operator is versatile and adaptable and adjusts accordingly to the varied mix of component, shape, size and complexity to deliver a perfectly acceptable result most of the time.

For almost as long, Guyson has also been selling automated blast machines, which have traditionally been introduced when high volumes of components are to be processed or when a higher degree of surface consistency and quality has been required.

Automated blasting improves on all those areas that are weak in manual blasting and brings key process parameters under control and provides a high degree of repeatability, so long as the geometry of the components is relatively simple. However, due to the linear nature (x-y axis) of traditional automated process control, when the shapes and contours of the components are complex, and the blasted surface finish is critical, a conventional automated blast system may not be able to meet all the precision component manufacturer's quality requirements.

For complex precision components and shot peening, robotically controlled blasting delivers an outstanding range of benefits. It delivers a precise blast stand off distance around the surface contour of the most complex shapes coupled with the minimum of overspray and the maximum of blast efficiency.

### Benefits include:

- Precise blast profile
- Repeatable surface treatment
- Simplified blast validation capabilities
- Fast set-up and recall of blast profiles to match components
- Lower running costs compared to multiple blast gun systems
  - Elimination of RSI and VWF operator injuries
  - Lights out blast procedure possible
  - Frees up operator personnel



# Benefits of robotic blasting

## Improved consistency in quality

Robotic blasting and advanced motion programming is having a dramatic impact on surface quality. Even when blasting components of the most complex shape, the correct angle, offset and surface speed are constantly maintained. Operator errors in blast gun and part manipulation can be eliminated, and the limitations of conventional automatic blast machines can be overcome, resulting in a major improvement in the degree of consistency in quality.

There are several other advantages of robotic blasting. One of the foremost is that, once a complete process recipe is established for a particular component, it can be stored and recalled at will, and the need for major blast machine set-up and adjustment procedures is eliminated, no matter if a short or long run of a particular part is required.

Automated and robotic blast machines that use PLC control to synchronize system functions may be equipped with a variety of electronic sensors and enhanced control features that support compliance with stringent surface roughness or shot peening almen intensity requirement standards. For example, in addition to monitoring and display of conditions such as media level, blast pressure, spindle rpm, media flow rate and nozzle motion, advanced systems can be designed with sieves and roundness classifiers, component recognition, data acquisition and logging capability to assist with the documentation of critical SPC (Statistical Process Control) process parameters.

Distribution Chart for Automatic Grit Blast Equipment

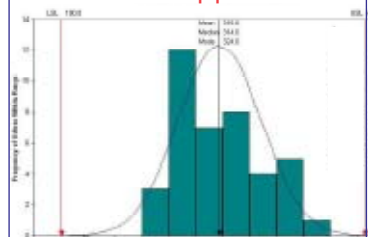

Surface Roughness

Distribution Chart for Robotic Grit Blast Equipment

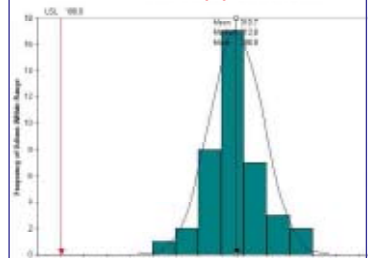

Surface Roughness





# Cost benefits

## Lower on-going running costs

Replacement of the human element in blast finishing brings benefits for the labour force with the elimination of Repetitive Strain Injuries (RSI) and Vibration White Finger (VWF) from operators of manual cabinets, where repetitive blasting tasks are undertaken.

Robots also enable the repeated handling of heavy components, blasting of hazardous substances or working in unpleasant environments. Other obvious benefits of the conversion to robotic blasting are labour and re-work savings, and the fact that human operators are freed for other work that demands their intelligence and judgement. By the elimination of wasted motion, process cycles can usually be reduced to a fraction of the time required for manual blasting. For a repeatable surface treatment, a single robotic blast system can out-produce several hand blast cabinets.

Adoption of these sophisticated new precision robotic blasting techniques reduces daily running cost savings. Lower compressed air consumption and blast media usage costs are achieved by the use of fewer blast guns owing to the more accurate blast profile. Additionally robotically controlled blast systems can often be specified with smaller dust collectors, reducing initial capital costs as well as reducing on-going waste disposal issues.



# Robotic blast finishing

## Two main types of robotic blast system

Robots have been used for some time in technological advanced component manufacturing, especially for operations such as grinding, buffing and polishing, and passive robotic pick and place systems may be used to load and unload one or more automated blast systems in a finishing or coating work cell. The integration of robots into the blast finishing and shot peening process is a more recent development, but it is one that is having far-reaching benefits for critical surface finishing and shot peening operators.

There are two main types of active robotic blast systems. In one type, the articulated robot arm manipulates the suction-blast gun, pressure-blast nozzle or an elongated lance nozzle. The end-of-arm tooling that actually holds the blast nozzle is designed to complement the robot's motions in coverage of target surfaces, and it is robustly fabricated to withstand the action of blast media. The component may be fixtured on a rotating spindle or table that can be controlled as an additional axis of robotic motion or the part may be mounted in fixed position that enables the nozzle manipulator to closely follow its contours.

In the second type of robotic blast machine, the robot grasps and manipulates the component, presenting the part to a blast nozzle that is locked in a fixed position. This type of system normally requires custom designed end-of-arm tooling in the form of a gripper that will accommodate the full range of components to be blasted, and it utilizes what is called remote tool point motion programming. The gripper assembly typically incorporates a deflector plate to shield the end-of-arm tooling from media over-spray.

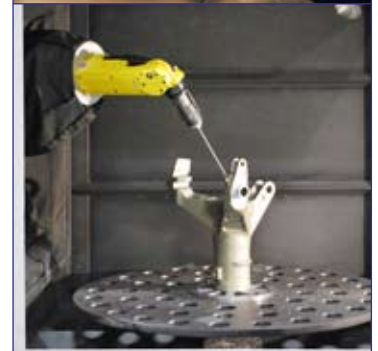



# Robot technology partners

## Guyson work with the leading robotic suppliers

Guyson recognises that many of its customers have existing relationships and preferences to their own robotic handling supplier. To facilitate this, Guyson will and does already does support and supply makes of robot and will be willing to undertake blast projects with any of the leading robotic suppliers. To assist with this customer integration, the Guyson group of industrial finishing equipment manufacturers, already has in place partnership agreements with leading robotics suppliers, ABB Robotics, Fanuc and Motoman.

By working with a range of robotic equipment suppliers Guyson can also offer a wider range of solutions, tailored to our specific customer requirements. Also providing reassurance to our customers that they will be provided with access to advanced technical support direct from the manufacturer, whoever their preferred choice is.



## Advanced robotic programming

While industrial robots are supplied with a teach pendant for development of motion programs, there is now a faster and more precise method available based on machine tool CAD/CAM technology. This is a significant breakthrough, since the many hours that a robotic blast system is tied-up during trial-and-error programming would be time that it is out of production.

The current state-of-the-art method of robot motion programming utilizes 3D modelling software, beginning with the creation of a parametric 3D model of the component that accurately represents all features of the part, as well as the end-of-arm tooling and structural features of the blast cabinet. The programming process is performed off-line, or even remotely, so production continues uninterrupted.

Parameters such as the distance from the nozzle to the part, the angle of the nozzle in relation to the target surface, and the speed at which the surface is traversed are set as rules of the CAD/CAM motion program. Unlike teach-pendant programming, the tool paths of the blast gun are not based on the care and best reckoning of the programmer, but upon the most efficient execution of all the required nozzle movements. An added benefit is that the computer simulation of the blasting process yields an extremely dependable calculation of the blast cycle time.

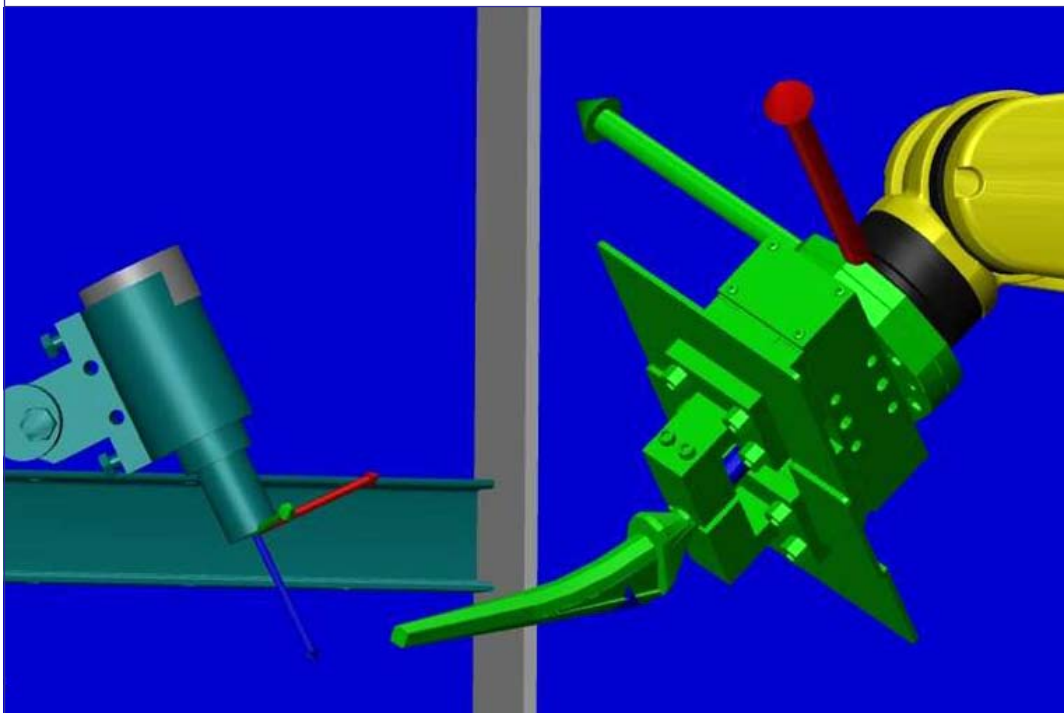



# Contacts

## UK

Sales, Design and  
Manufacturing Centre  
Guyson International Ltd.  
Snaygill Industrial Estate  
Keighley Road, Skipton  
North Yorkshire, BD23 2QR  
Tel: +44 (0)1756 799911  
Fax: +44 (0)1756 790213  
email: info@guyson.co.uk  
www.guyson.co.uk

## France

Sales and Service Centre  
Guyson SA  
1 Rue Du Gué  
77990 Le Mesnil Amelot  
France  
Tel: +33 (0)1 60 27 25 00  
Fax: +33 (0)1 60 27 25 09  
email: contact@guyson.fr  
www.guyson.fr

## USA

Design and Manufacturing Centre  
Guyson Corporation of USA  
W.J. Grande Industrial Park  
13 Grande Blvd.  
Saratoga Springs  
NY 12866-9090  
Tel: +1 518 587 7894  
Fax: +1 518 587 7840  
email: info@guyson.com  
www.guyson.com

## Malaysia

Sales and Service Centre  
Guyson SDN BHD  
Shoplot 10, G/F Hotel Equatorial  
1 Jalan Bukit Jambul  
11900 Penang  
Tel: +60 46 41 49 95  
Fax: +60 46 41 50 03  
email: kernypg@guyson.co.uk

## China

Sales and Service Centre  
Guyson SDN BHD -  
Wuxi Representative Office  
RM1206, East Yunding Building  
Xianqiandong Road  
Wuxi  
Jiangsu Province  
P.R. China  
Postal code: 214002  
Tel: +86 510 82790120  
Fax: +86 510 82790120  
email: zzlzhly@guyson.co.uk



FM 38758  
ISO 9001:2008

# Guyson International



Guyson International Limited is the largest independent manufacturer of blast finishing, spray washing and ultrasonic cleaning equipment in Europe and supplies a worldwide customer base. Guyson offer automated handling solutions, where suitable, including both robot load & unload and also pick & place options.

Comprehensive ranges of automatic and manual blast cabinet systems are available to suit all production situations. Specialist applications include surface treatment of medical implants, shot peening of turbine blades and surface preparation of components such as cutting tools, to improve coating adhesion, prior to PVD coating.

Ultrasonic equipment includes bench top baths for laboratory, medical and light industrial use and ultrasonic cleaning tanks for industrial use. Microsolve systems for precision cleaning in wide range of sectors including electronics, optics, aerospace and defence, as well as multi-stage aqueous ultrasonic systems for specialised cleaning of components such as medical implants, hard disk drives, diamonds, optics etc.

Also available are a range of aqueous spray wash equipment including conveyerised tunnel washers, rotary basket washers, rotary drum washer for small parts, a PCB stencil cleaner and a compact high impact hot aqueous spray washer designed for the workshop. Full product and application information for all equipment is available on the Guyson website.

