

RCACR-SA4C

Cleanroom ROBO Cylinder, Slider Type, Coupled, Actuator Width 40mm, 24V Servo Motor, Aluminum Base

Model Specification Items	RCACR — SA4C	— Encoder type —	20	— Motor type —	— Lead —	— Stroke —	— Applicable controller —	— Cable length —	— Options —
	Series — Type	— Encoder type —	Motor type	Lead	Stroke	Applicable controller	Cable length	Options	See Options below.
	I: Incremental A: Absolute	20: 20W Servo motor	10: 10mm 5: 5mm 2.5: 2.5mm	50: 50mm { 400: 400mm (50mm pitch increments)	A1: ACON ASEL A3: AMEC ASEP MSEP	N: None P: 1m S: 3m M: 5m X□□: Custom length R□□: Robot cable			

* See page Pre-47 for details on the model descriptions.
* Absolute encoder models can only use ASEL. When the actuator is used with the simple absolute encoder, the model is considered an incremental model.



Power-saving



Technical References Appendix P.5



- (1) When the stroke increases, the maximum will drop to prevent the ball screw from reaching the critical rotational speed. Use the actuator specification table below to check the maximum speed at the stroke you desire.
- (2) The load capacity is based on operation at an acceleration of 0.3G (0.2G for the 2.5mm-lead model). These values are the upper limits for the acceleration.
- (3) See page A-71 for details on push motion.

*This product is equipped with a position adjusting screw at the A area shown above. (See dimensional drawing on the page to the right.)

Actuator Specifications

Lead and Payload

Model number	Motor output (W)	Lead (mm)	Max. Load Capacity		Rated thrust (N)	Stroke (mm)
			Horizontal (kg)	Vertical (kg)		
RCACR-SA4C-①-20-10-②-③-④-⑤	20	10	4	1	19.6	50~400 (every 50mm)
RCACR-SA4C-①-20-5-②-③-④-⑤		5	6	2.5	39.2	
RCACR-SA4C-①-20-2.5-②-③-④-⑤		2.5	8	4.5	78.4	

Stroke and Max. Speed/Suction Volume by Lead

Stroke Lead	50~400 (every 50mm)	Suction Volume (Nℓ/min)
10	665	50
5	330	30
2.5	165	15

Code explanation ① Encoder ② Stroke ③ Applicable Controller ④ Cable length ⑤ Options *See page A-71 for details on push motion. (Unit: mm/s)

① Encoder type/② Stroke

② Stroke (mm)	Standard price	
	① Encoder Type	
	Incremental	Absolute
	I	A
50	—	—
100	—	—
150	—	—
200	—	—
250	—	—
300	—	—
350	—	—
400	—	—

④ Cable Length

Type	Cable symbol	Standard price
Standard	P (1m)	—
	S (3m)	—
	M (5m)	—
Special length	X06 (6m) ~ X10 (10m)	—
	X11 (11m) ~ X15 (15m)	—
	X16 (16m) ~ X20 (20m)	—
	R01 (1m) ~ R03 (3m)	—
Robot Cable	R04 (4m) ~ R05 (5m)	—
	R06 (6m) ~ R10 (10m)	—
	R11 (11m) ~ R15 (15m)	—
	R16 (16m) ~ R20 (20m)	—
	R16 (16m) ~ R20 (20m)	—

* See page A-59 for cables for maintenance.

⑤ Options

Name	Option code	See page	Standard price
Brake	B	→ A-42	—
Foot bracket	FT	→ A-48	—
Home sensor	HS	→ A-50	—
Power-saving	LA	→ A-52	—
Non-motor end specification	NM	→ A-52	—
Slider spacer	SS	→ A-55	—
Vacuum port on opposite side	VR	→ A-58	—

Actuator Specifications

Item	Description
Drive System	Ball screw, ø8mm, rolled C10
Positioning repeatability	±0.02mm
Lost Motion	0.1mm or less
Base	Material: Aluminum, white alumite treated
Allowable static moment	Ma: 6.9 N·m, Mb: 9.9 N·m, Mc: 17.0 N·m
Allowable dynamic moment (*)	Ma: 2.7 N·m, Mb: 3.9 N·m, Mc: 6.8 N·m
Allowable overhang	120mm or less in Ma, Mb and Mc directions
Grease Type	Low dust generation grease (both ball screw and guide)
Cleanliness	Class 10 (0.1µm)
Ambient operating temperature, humidity	0 to 40°C, 85% RH or less (Non-condensing)

(*) Based on 5,000km of traveling life

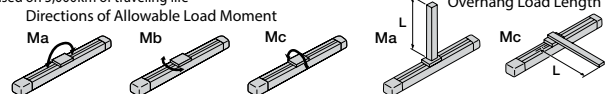

Dimensional Drawings

CAD drawings can be downloaded from the website.

www.intelligentactuator.com

For Special Orders

Appendix P.15



- (*1) Connect the motor and encoder cables here. See page A-59 for details on cables.
- (*2) After homing, the slider moves to the ME, therefore, please watch for any interference with surrounding objects.
ME: Mechanical end SE: Stroke end
- (*3) Reference position for calculating the moment Ma.

(*4) If the actuator is secured using only the mounting holes provided on the top surface of the base, the base may twist to cause abnormal sliding of the slider, or may produce abnormal noise. Therefore, when using the mounting holes on the top surface of the base, keep the stroke at 200mm or less.

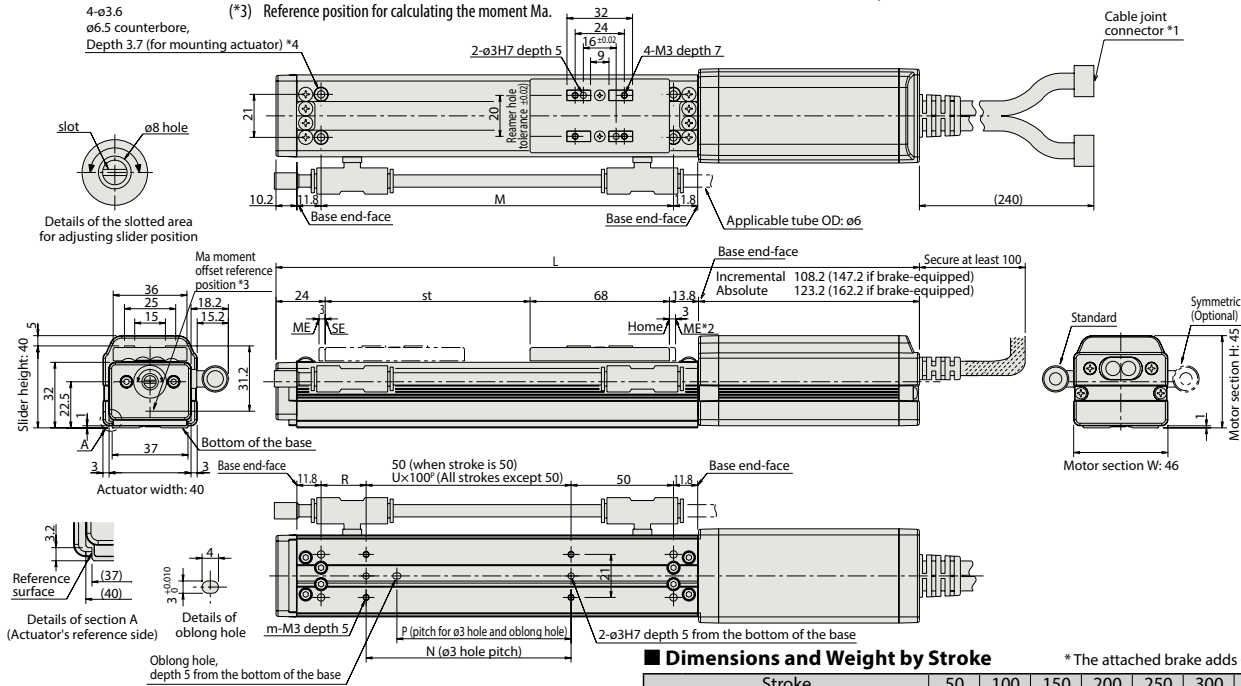

Dimensions and Weight by Stroke

* The attached brake adds 0.3kg of mass.

Stroke		50	100	150	200	250	300	350	400	
L	Incremental	Without brake	264	314	364	414	464	514	564	614
		With brake	303	353	403	453	503	553	603	653
	Absolute	Without brake	279	329	379	429	479	529	579	629
		With brake	318	368	418	468	518	568	618	668
M		122	172	222	272	322	372	422	472	
N		50	100	100	200	200	300	300	400	
P		35	85	85	185	185	285	285	385	
R		22	22	72	22	72	22	72	22	
U		-	1	1	2	2	3	3	4	
m		4	4	4	6	6	8	8	10	
Weight (kg)		0.7	0.8	0.9	1	1.1	1.2	1.3	1.4	

Applicable Controllers

RCACR series actuators can be operated with the controllers indicated below. Select the type according to your intended application.

Name	External view	Model number	Features	Maximum number of positioning points	Input power	Power-supply capacity	Standard price	Reference page
Solenoid Valve Type		AMEC-C-20I-①-②-2-1	Easy-to-use controller, even for beginners	3 points	AC100V	2.4A rated	—	→ P537
		ASEP-C-20I-①-②-2-0	Simple controller operable with the same signal as a solenoid valve					→ P547
Solenoid valve multi-axis type PIO specification		MSEP-C-④-⑤-⑥-2-0	Positioner type based on PIO control, allowing up to 8 axes to be connected	256 points	DC24V	(Standard) 1.3A rated 4.4A max. (Power-saving) 1.3A rated 2.5A max.	—	→ P563
Solenoid valve multi-axis type Network specification		MSEP-C-④-⑤-⑥-0-0	Field network-ready positioner type, allowing up to 8 axes to be connected					
Positioner type		ACON-C-20I-①-②-2-0	Positioning is possible for up to 512 points	512 points	DC24V	(Standard) 1.3A rated 4.4A max. (Power-saving) 1.3A rated 2.5A max.	—	—
Safety-Compliant Positioner Type		ACON-CG-20I-①-②-2-0						
Pulse Train Input Type (Differential Line Driver)		ACON-PL-20I-①-②-2-0	Pulse train input type with differential line driver support	(—)	DC24V	(Standard) 1.3A rated 4.4A max. (Power-saving) 1.3A rated 2.5A max.	—	→ P631
Pulse Train Input Type (Open Collector)		ACON-PO-20I-①-②-2-0						
Serial Communication Type		ACON-SE-20I-①-N-0-0	Dedicated Serial Communication	64 points	DC24V	(Standard) 1.3A rated 4.4A max. (Power-saving) 1.3A rated 2.5A max.	—	—
Program Control Type		ASEL-CS-1-20I-①-②-2-0	Programmed operation is possible. Can operate up to 2 axes	1,500 points	DC24V	(Standard) 1.3A rated 4.4A max. (Power-saving) 1.3A rated 2.5A max.	—	→ P675

* This is for the single-axis ASEL.
* ① indicates I/O type (NP/PN).

* ① indicates encoder type (I: incremental, A: absolute)
* ④ indicates number of axes (1 to 8).

* Enter the code "LA" in ① when the power-saving option is specified.
* ⑤ indicates field network specification symbol.

Slider Type

Mini

Standard

Controllers Integrated

Rod Type

Mini

Standard

Controllers Integrated

Table/Arm/Flat Type

Mini

Standard

Gripper/Rotary Type

Linear Servo Type

Clean-room Type

Splash-Proof Type

Pulse Motor

Servo Motor (24V)

Servo Motor (200V)

Linear Servo Motor