

50W Single Output Switching Power Supply

HF50W-SML M1 Series



FEATURES

- Universal AC input / full range
- Compact size, high reliability
- Japanese brand components for key parts
- Electrolytic capacitors all 105°C
- 100% full load burn-in test
- Protections: overload/ over voltage/ short circuit
- 5 years limited warranty
- F603 129 x 98 x 40mm

SPECIFICATIONS

Input Voltage	85~264VAC (120~370VDC)
Input Current	1.5A
Input Frequency	47~63Hz
Inrush Current	cold start, 20A/115V, 40A/230V
Input Leakage Current	< 0.7mA/230VAC
Line Regulation (full load)	± 0.5%
Voltage Adjust Range	± 10%
Output Overload Protection	105~150%, hiccup mode, auto recovery
Short Circuit Protection	hiccup mode, auto recovery
Rise Time	50ms @full load (typical)
Hold up Time	20ms @full load (typical)
Mechanical Feature	enclosed
Dimensions	129 x 98 x 40mm (L x W x H)
Connection	5P/9.5mm screw terminal Block

Operating Temperature	-20°C ~+70°C(ref. derating curve)
Storage Temperature	-20°C ~+85°C
Operating Humidity	20%~93%RH(non condensing)
Storage Humidity	20%~95%RH(non condensing)
MTBF	>100,000 hours
Cooling	convection
Safety Standards	design meet GB4943, UL60950, EN60950
EMC Standards	design meet GB9254, EN55022 Class A, EN61000-3-2,3 EN61000-4-2,3,4,5,6,8,11
Withstand Voltage	I/P -O/P: 1.5KVAC/1min I/P - PE: 1.5KVAC/1min O/P-PE: 0.5KVAC/1min
Vibration	10~150Hz, 2G 10min/1cycle, 30min each along X, Y, Z axes
Packing	0.36kgs, 42pcs/17kgs/0.035CBM per carton

Model No.	DC Output	Rated Power	Load Regulation	Voltage Tolerance	Ripple & Noise (max.)	Efficiency
HF50W-SML-5	5V 10.0A	50.0W	0.5%	± 2%	80mVp-p	77%
HF50W-SML-12	12V 4.2A	50.4W	0.5%	± 1%	120mVp-p	83%
HF50W-SML-15	15V 3.4A	51.0W	0.5%	± 1%	120mVp-p	83%
HF50W-SML-24	24V 2.1A	50.4W	0.5%	± 1%	150mVp-p	84%
HF50W-SML-48	48V 1.0A	48.0W	0.5%	± 1%	150mVp-p	84%

* 3~48VDC output all available

NOTE

1. All parameters are measured at 230VAC input, rated load and 25°C of ambient temperature.
2. Line regulation is measured from low line to high line at rated load.
3. Load regulation is measured from 0% to 100% of rated load for single output models. For multi-output models, it is measured from 20% to 100% of rated load, and other output at 60% rated load.
4. Ripple & noise are measured at 20MHz of bandwidth by using a 12" twisted pair-wire terminated with a 0.1uF & 47uF parallel capacitor.
5. The power supply is regarded as a component which will be installed into a final equipment. The final equipment must be re-confirmed that it still meets EMC directives.

Drawing

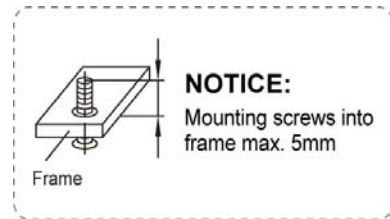
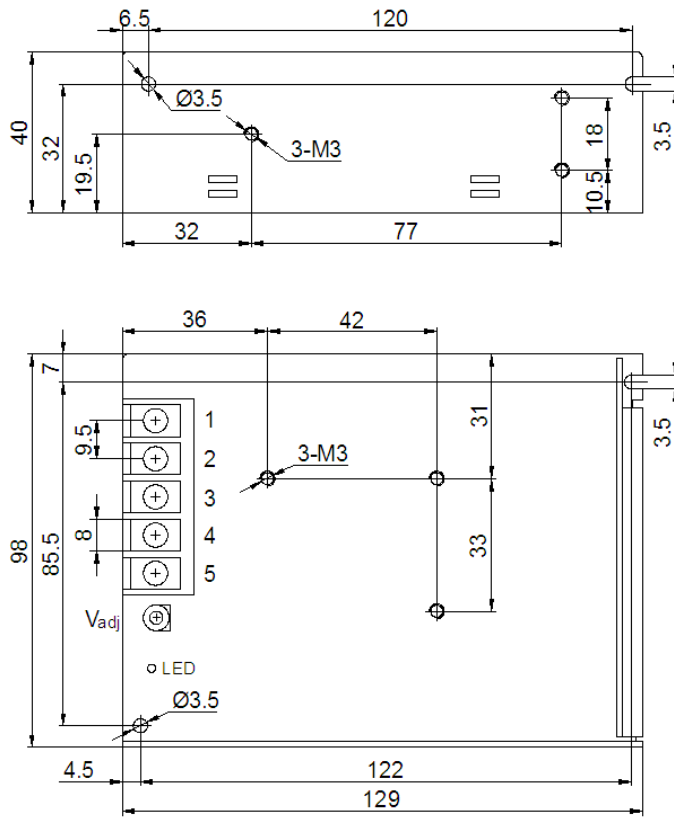

Terminal Pin No. Assignment

Pin No.	Assignment	Pin No.	Assignment
1	AC/L	4	DC OUTPUT -V
2	AC/N	5	DC OUTPUT +V
3	PE		

Derating Curve

