

200W DC/DC Switching Power Supply

HF200W-SD Series



FEATURES

- Full DC input range
- High reliability
- Japanese brand components for key parts
- Electrolytic capacitors all 105°C
- 100% full load burn-in test
- Protections: overload/ short circuit
- 5 years limited warranty
- F620 200 x 110 x 50mm

SPECIFICATIONS

DC Input Voltage	24V(18~36), 48V(36~72) 110V(72~144)VDC
Line Regulation (full load)	± 0.5%
Voltage Adjust Range	± 10%
Output Overload Protection	105~150%
Short Circuit Protection	hiccup mode, auto recovery
Rise Time	50ms @full load (typical)
Mechanical Feature	enclosed
Dimensions	200 x 110 x 50mm (L x W x H)
Operating Temperature	-20°C ~+50°C
Storage Temperature	-20°C ~+85°C
Operating Humidity	20%~93%RH(non condensing)
Storage Humidity	20%~95%RH(non condensing)

MTBF	>100,000 hours
Cooling	convection
Safety Standards	design refer to GB4943, UL60950, EN60950
EMC Standards	design refer to GB9254, EN55022 Class A
Withstand Voltage	I/P -O/P: 1.5KVAC/1min I/P - PE: 1.5KVAC/1min O/P-PE: 0.5KVAC/1min
Isolation Resistance	>100MΩ@500VDC
Vibration	10~150Hz, 2G 10min/1cycle, 30min each along X, Y, Z axes
Connection	7P/9.5mm screw terminal block
Packing	0.83kgs, 20pcs/18.5kgs/0.045CBM per carton

Model No.	DC Output	Rated Power	Load Regulation	Voltage Tolerance	Ripple & Noise (max.)	Efficiency
HF200W-SD24-5	5V 30.0A	175.0W	0.5%	± 2%	100mVp-p	79%
HF200W-SD48-5	5V 30.0A	175.0W	0.5%	± 2%	100mVp-p	81%
HF200W-SD110-5	5V 30.0A	175.0W	0.5%	± 2%	100mVp-p	81%
HF200W-SD24-12	12V 16.7A	200.4W	0.5%	± 1%	120mVp-p	82%
HF200W-SD48-12	12V 16.7A	200.4W	0.5%	± 1%	120mVp-p	86%
HF200W-SD110-12	12V 16.7A	200.4W	0.5%	± 1%	120mVp-p	87%
HF200W-SD24-24	24V 8.4A	201.6W	0.5%	± 1%	150mVp-p	85%
HF200W-SD48-24	24V 8.4A	201.6W	0.5%	± 1%	150mVp-p	88%
HF200W-SD110-24	24V 8.4A	201.6W	0.5%	± 1%	150mVp-p	91%
HF240W-SD24-24	24V 10.0A	240.0W	0.5%	± 1%	150mVp-p	83%
HF240W-SD48-24	24V 10.0A	240.0W	0.5%	± 1%	150mVp-p	85%
HF240W-SD110-24	24V 10.0A	240.0W	0.5%	± 1%	150mVp-p	88%
HF200W-SD24-48	48V 4.2A	201.6W	0.5%	± 1%	150mVp-p	84%
HF200W-SD48-48	48V 4.2A	201.6W	0.5%	± 1%	150mVp-p	90%
HF200W-SD110-48	48V 4.2A	201.6W	0.5%	± 1%	150mVp-p	90%

NOTE

1. All parameters are measured at rated input voltage, rated load and 25°C of ambient temperature.
2. Line regulation is measured from low line to high line at rated load.
3. Load regulation is measured from 0% to 100% of rated load for single output models. For multi-output models, it is measured from 20% to 100% of rated load, and other output at 60% rated load.

4. Ripple & noise are measured at 20MHz of bandwidth by using a 12" twisted pair-wire terminated with a 0.1uF & 47uF parallel capacitor.
5. The power supply is regarded as a component which will be installed into a final equipment. The final equipment must be re-confirmed that it still meets EMC directives.

Drawing

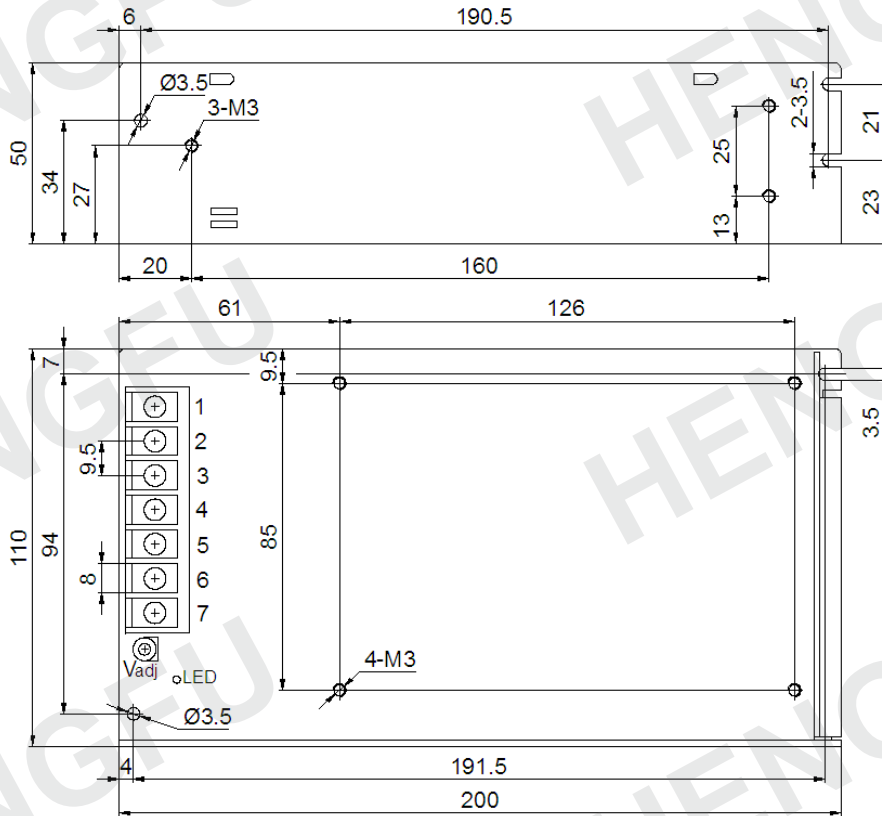

Length of assembly screw: max. 6mm

Terminal Pin No. Assignment

Pin No.	Assignment	Pin No.	Assignment
1	DC INPUT -V	4,5	DC OUTPUT -V
2	DC INPUT +V	6,7	DC OUTPUT +V
3	PE		