

"Y"形孔管材

Milling Cutter Blanks with Center Coolant Duct and 2、3、4、5 Lateral Exits

- **适用范围 /Application Area:**
前端带多个内冷孔刀具/ Milling Cutter with Center Coolant Duct and Many Lateral Exits
- **产品规格/Type:**
直径/Diameter $\varnothing 6\text{-}\varnothing 25$ mm、长度/Length 50-200 mm, 其它尺寸根据图纸定制/ Customized.
- **尺寸精度/Production Category:**
外径 (H6/H5) ; 内孔径D2参照单直孔管材精度; 斜孔径D3 ± 0.15 mm; 长度L1 $\pm 1.0/0$ mm; 斜孔与管材外圆柱面相贯圆的圆心到管材端面的距离L2 ± 0.3 mm; 倒角尺寸参照公制精磨倒角棒标准

单位:mm

金鹭产品类别 H2/H7 : ISO h6/ ISO h5 GESAC Production Category H2/H7					
规格 Type	D1	L	L2	D2	D3
GN32060058	6	58	55	1.75 \pm 0.15	1.0 \pm 0.15
GN32060065	6	65	62	1.75 \pm 0.15	1.0 \pm 0.15
GN32060076	6	76.5	73	1.75 \pm 0.15	1.0 \pm 0.15
GN32080064	8	64.2	60	1.75 \pm 0.15	1.2 \pm 0.15
GN32080079	8	79	74.8	1.75 \pm 0.15	1.2 \pm 0.15
GN32080101	8	101.2	97	1.75 \pm 0.15	1.2 \pm 0.15
GN32100067	10	67.2	62	2 \pm 0.20	1.2 \pm 0.15
GN32100073	10	73.2	68	2 \pm 0.20	1.2 \pm 0.15
GN32100101	10	101.2	96	2 \pm 0.20	1.2 \pm 0.15
GN32120074	12	74.2	68	2 \pm 0.20	1.5 \pm 0.15
GN32120084	12	84.2	78	2 \pm 0.20	1.5 \pm 0.15
GN32120101	12	101.1	95	2 \pm 0.20	1.5 \pm 0.15
GN32140084	14	84.2	77	2 \pm 0.20	1.5 \pm 0.15
GN32140101	14	101.2	94	2 \pm 0.20	1.5 \pm 0.15

金鹭产品类别 H2/H7 : ISO h6/ ISO h5 GESAC Production Category H2/H7					
规格 Type	D1	L	L2	D2	D3
GN32160083	16	83.2	75	4 \pm 0.25	1.5 \pm 0.15
GN32160093	16	93.2	85	4 \pm 0.25	1.5 \pm 0.15
GN32160101	16	101.2	93	4 \pm 0.25	1.5 \pm 0.15
GN32160128	16	128	119.8	4 \pm 0.25	1.5 \pm 0.15
GN32180093	18	93	84	4 \pm 0.25	2.0 \pm 0.15
GN32180102	18	102	93	4 \pm 0.25	2.0 \pm 0.15
GN32180151	18	151.3	142	4 \pm 0.25	2.0 \pm 0.15
GN32200093	20	93.2	83	4 \pm 0.25	2.0 \pm 0.15
GN32200105	20	105	95	4 \pm 0.25	2.0 \pm 0.15
GN32200110	20	110	99.8	4 \pm 0.25	2.0 \pm 0.15
GN32200152	20	151.2	141	4 \pm 0.25	2.0 \pm 0.15
GN32250122	25	122	109.5	4 \pm 0.25	2.0 \pm 0.15
GN32250130	25	130	117.5	4 \pm 0.25	2.0 \pm 0.15
GN32250152	25	152	139.5	4 \pm 0.25	2.0 \pm 0.15
GN32250185	25	185	172.5	4 \pm 0.25	2.0 \pm 0.15

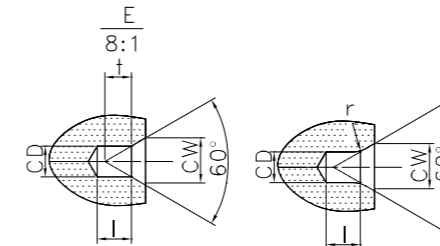
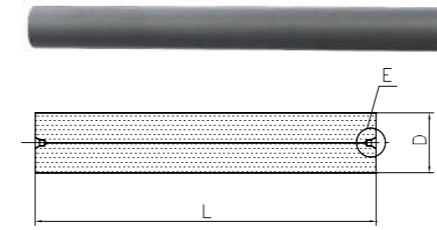
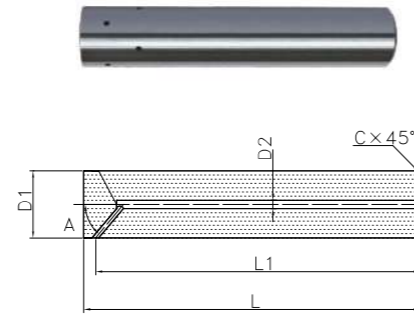

A型中心定位孔

R型中心定位孔

带中心定位孔棒

Rods with Center Holes

- **适用范围 /Application Area:**
大长径比刀具/Tools of Large aspect ratio
- **加工范围/Range:**
直径/Diameter $\varnothing 4\text{-}\varnothing 40$ mm、长度/Length 30-330 mm
- **尺寸精度/Production Category:**
其它尺寸根据图纸定制/ Customized.

产品类别 H0: 毛坯 Production Category H0: Blanks		
A型60° 中心孔		R型60° 中心孔
0.8 \times 1.70		—
1.0 \times 2.12		1.0 \times 2.12
1.25 \times 2.65		1.25 \times 2.65
1.6 \times 3.35		1.6 \times 3.35
2.0 \times 4.25		2.0 \times 4.25

- (1) 三斜孔系列型号为GN32 The code for series with 3 lateral exits is GN32
- (2) 双斜孔系列型号为GN22 The code for series with 2 lateral exits is GN22
- (3) 四斜孔系列型号为GN42 The code for series with 4 lateral exits is GN42

■ **订货示例 Ordering Example:**

(橙色背景为订货范例规格 The type is for ordering example, whose bottom is orange.)

订货需求表 Ordering Table						
序号 NO.	牌号 Grade	订货规格 Ordering Type	产品类别-规格 Production Category & Type	公差 Tol.	数量 Amounts	备注 Remark
1	GU20	H2-GN32060058		GESAC 标准	5000	
2						

○ 不注明公差, 则默认GESAC 标准 It will be taken as GESAC standard, if no tolerance is offered.