

# Starrett®

Precision, **Quality**, Innovation

## PRECISION TOOLS

**Slide** Calipers

Height **Gauges**

**Micrometers**

**Bore** Gauges

**Indicators**

Indicator **Stands**

**Fixed** Gauges

**Precision** Tools

**Metrology**

Optical **Profile Projectors**



# PRECISION, QUALITY, INNOVATION

Welcome to our new edition, Catalogue 33E. We remain as dedicated today to the making of great tools for our customers as we were when L.S. Starrett founded the company in 1880. He created a business and a brand that has become synonymous with precision, quality and innovation, backed by unmatched service and support.

We accomplish this by offering application-designed precision tools, saws, and custom solutions that optimise job and process performance. Our confidence hinges on over 130 years of experience focusing on your needs and your success. We take great pride in manufacturing long-lasting, easy-to-use tools that provide consistent and reliable performance.

Today, Starrett offers five product categories: Precision Measurement Tools, Metrology Equipment, Granite-based Engineered Solutions, Saw Blades, and Jobsite and Shop Tools.

Whether you need to modify a standard tool, require assistance in selecting the best saw blade for your cutting application, or desire a custom solution for your business, we have the breadth of knowledge to assist you.

We are committed to providing you with complete solutions created for your exact needs. Problem solving is part of what we do every day. If the right tool for your application does not exist, contact us – we would appreciate the opportunity to build it.

*D.A. Starrett*

President and CEO



## SLIDE CALIPERS

Vernier Calipers	6
Dial Calipers	6
Electronic Calipers	7
Carbon Fibre Calipers	8-9

## 06 - 09



## INDICATOR STANDS

Indicator Holders / Stands	38
----------------------------	----

## 38



## DEPTH AND HEIGHT GAUGES

Electronic Depth Gauges	10-11
Dial Height Gauge	11
Electronic Height Gauges	12-14

## 10 - 14



## FIXED GAUGES

Taper Gauges	39
Thickness Gauges	39
Screw Pitch Gauges	40
Thickness Gauges / Feeler Stock	41

## 39 - 41



## MICROMETERS

Outside Micrometers	15
Electronic Outside Micrometers	16-17
Anvil Micrometers	18
Can Seam Micrometers	18
Blade Micrometers	19
Disc Micrometers	20
Inside Micrometer Sets	21
Depth Micrometers	22
Bench Micrometers	22

## 15 - 22



## PRECISION SHOP TOOLS

Instrument Oil and Layout Dye	42
Edge Finders	42
Centre Punches	43
Punches and Punch Sets	44
Levels	45
Combination Sets	46
Squares and Parallels	46
Gauge Block Sets	47-49

## 42 - 49



## BORE GAUGES

Hole Gauges	23
Telescoping Gauges	23
Dial Bore Gauges	24
Mechanical Bore Gauges	25
Electronic Bore Gauges	26
Bore Gauge Heads	27-28
Bore Gauge Systems	29-30

## 23 - 30



## METROLOGY

Video Borescopes	50
Bench Hardness Testers	51
Test Blocks and Accessories	52-53
Portable Hardness Testers	54-55
Durometer	56
Ultrasonic Thickness Gauges	56
Roughness Testers	57-59
Roundness Testers	60-62

## 50 - 62



## INDICATORS

Dial Indicators	31
Mechanical Test Indicators	32
Electronic Indicators	33-34
Back Plunger Indicators	35
Special Function Indicators	36-37

## 31 - 37



## OPTICAL PROFILE PROJECTORS

HE400 Horizontal Bench Top Optical Profile Projector	63
VB400 Vertical Bench Top Optical Profile Projector	64
Accessories for Optical Profile Projectors	65
Digital Readouts for Optical Profile Projectors	66

## 63 - 66



# FACTORIES AROUND THE WORLD



1-Athol, Massachusetts, USA



2-Laguna Hills, California, USA



3-Waite Park, Minnesota, USA



4-Cleveland, Ohio, USA



● Starrett Manufacturing Factories

● Starrett Distribution Centres and Offices



5-Mount Airy, North Carolina, USA



6-Itu, São Paulo, Brazil



7-Jedburgh, Scotland



8-Suzhou, China



## VERNIER CALIPERS

### 125 & 1251

#### VERNIER CALIPERS

High quality, basic vernier caliper that offers inch and metric measurement

- Standard: DIN 862
- Measure outside diameter, inside diameter, depth and step
- Stainless steel hardened, ground and lapped measuring surfaces
- Lock screw for sliding jaw
- Fine adjustment thumbwheel for 1251 series

Cat No	Range	Graduation
125MEB-6/150	150mm / 6"	0.05mm / 1/128"
125MEB-8/200	200mm / 8"	0.05mm / 1/128"
125MEB-12/300	300mm / 12"	0.05mm / 1/128"
125MEA-6/150	150mm / 6"	0.02mm / 0.001"
125MEA-8/200	200mm / 8"	0.02mm / 0.001"
125MEA-12/300	300mm / 12"	0.02mm / 0.001"
1251MEA-12/300	300mm / 12"	0.02mm / 0.001"
1251MEA-20/500	500mm / 20"	0.02mm / 0.001"
1251MEA-24/600	600mm / 24"	0.02mm / 0.001"
1251MEA-40/1000	1000mm / 40"	0.02mm / 0.001"



## DIAL CALIPERS

### 3202

#### DIAL CALIPERS

With the ability to provide quick, accurate measurement of outside diameter, inside diameter, thickness and depth, the dial caliper is the most versatile precision measuring tool used in industry today.

- Standard: DIN 862
- Smooth sliding, anti shock new design dial movement
- Hardened stainless steel bar, measuring surfaces, rack, gears and depth bar
- Lock screws for dial bezel and for holding the sliding jaw in position.
- Thumb-operated fine adjustment roll
- Positive split gear anti-backlash control

Cat No	Range	Resolution
3202M-150	150mm	0.02mm
3202M-200	200mm	0.02mm
3202M-300	300mm	0.02mm
3202-6	6"	0.001"
3202-8	8"	0.001"
3202-12	12"	0.001"



# ELECTRONIC CALIPERS

## EC799 & 799 ELECTRONIC CALIPERS



The 799 Electronic Caliper is light, comfortable and easy-to-use, with a slim, streamlined profile and a large, LCD display.

- Standard: DIN 862
- High quality guide surfaces for smooth slider movement
- Hardened stainless steel measuring surfaces
- Fine adjustment thumb wheel
- Lock screw for sliding jaw
- Metric / inch conversion
- Zero set at any position
- Manual / auto off after 30 minutes of non use

Cat No	Range	Resolution
EC799A-6/150	150mm / 6"	0.01mm / 0.0005"
EC799A-8/200	200mm / 8"	0.01mm / 0.0005"
EC799A-12/300	300mm / 12"	0.01mm / 0.0005"
799AZ-24/600	600mm / 24"	0.01mm / 0.0005"
799AZ-40/1000	1000mm / 40"	0.01mm / 0.0005"
PT99492	3 Volt Battery, CR2032	

## 798 IP67 ELECTRONIC CALIPERS

The 798 Electronic Caliper features a large, easy-to-read, high contrast LCD readout. Its induction type linear encoder system includes IP67 protection against coolants, water, chips, dust and dirt often found in machine shop environments.

- Standard: DIN 862
- High quality guide surfaces for smooth slider movement
- Hardened stainless steel measuring surfaces
- Fine adjustment thumb wheel
- Lock screw for sliding jaw
- Metric / inch conversion
- Zero set at any position
- Memory retention of last display setting
- Data output on 798B series
- Manual / auto off after 30 minutes of non use

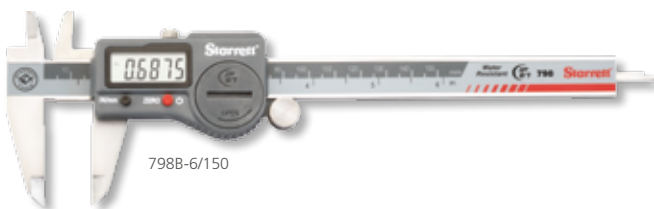

Cat No.	Range	Resolution
798A-6/150	150mm / 6"	0.01mm / 0.0005"
798A-8/200	200mm / 8"	0.01mm / 0.0005"
798A-12/300	300mm / 12"	0.01mm / 0.0005"
Data Output	798B-6/150	150mm / 6"
	798B-8/200	200mm / 8"
	798B-12/300	300mm / 12"
PT99492	3 Volt Battery, CR2032, (2 Required)	



### IP PROTECTION

An IP number is composed of two numbers, the first referring to protection against solid objects and the second against liquids.

**First number 6:** Totally protected against dust

**Second number 7:** Protection against submersion in water under standardised conditions of pressure for 30 minutes.

# CARBON FIBRE CALIPERS

## 5000 & 5002

### ELECTRONIC CARBON FIBRE CALIPERS

Starrett carbon fibre calipers are extremely light, comfortable and easy to use. IP67 protection makes these calipers suitable for use in workshop conditions exposed to coolant, water, dust or oil.

- Standard: DIN 862
- Titanium coated stainless steel outside measurement jaws for long life and superior flatness
- Two preset modes, REF I and REF II, allowing the set of one mode to a setting master and the second mode to a zero setting
- Metric / inch conversion
- Zero setting at any point
- Data output on 5000 and 5002 series
- Manual / auto off after 30 minutes of non use
- Hold feature will freeze the display when in REF I or REF II mode

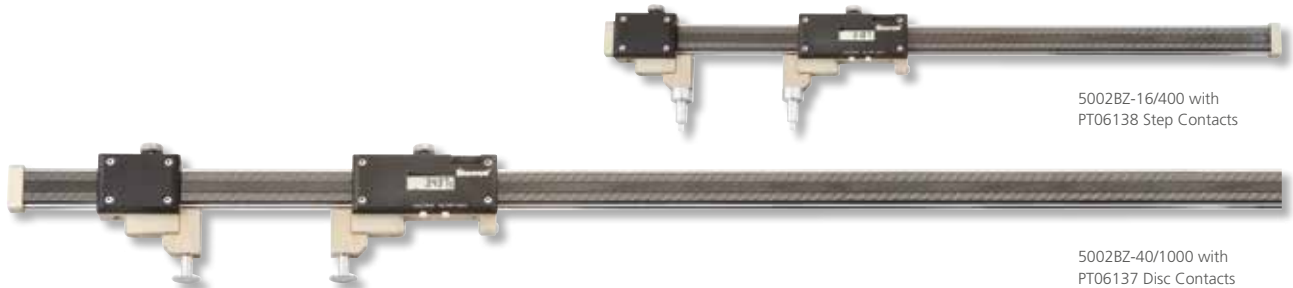

Cat No	Range			Resolution	Jaw Depth	Weight
	Outside	Inside (w/Jaws)	Inside (w/Top pins)			
B5000BZ-20/500	0-500mm / 0-20"	20-500mm	10-500mm	0.01mm / 0.0005"	125mm	1.10kg
B5000BZ-24/600	0-600mm / 0-24"	20-600mm	10-600mm	0.01mm / 0.0005"	125mm	1.16kg
B5000BZ-40/1000	0-1000mm / 0-40"	20-1000mm	10-1000mm	0.01mm / 0.0005"	125mm	2.40kg

Cat No	Range	Resolution	Weight
5002BZ-16/400	400mm / 16"	0.01mm / 0.0005"	0.75kg
50002BZ-24/600	600mm / 24"	0.01mm / 0.0005"	0.90kg
5002BZ-40/1000	1000mm / 40"	0.01mm / 0.0005"	1.50kg

Cat No	Description
PT06137	Disc contact for 5002
PT06138	Step contacts for 5002
PT06139	Cone contacts for 5002
PT99492	3 Volt Battery CR2032

5002BZ-24/600 with PT06139 Conical Contacts





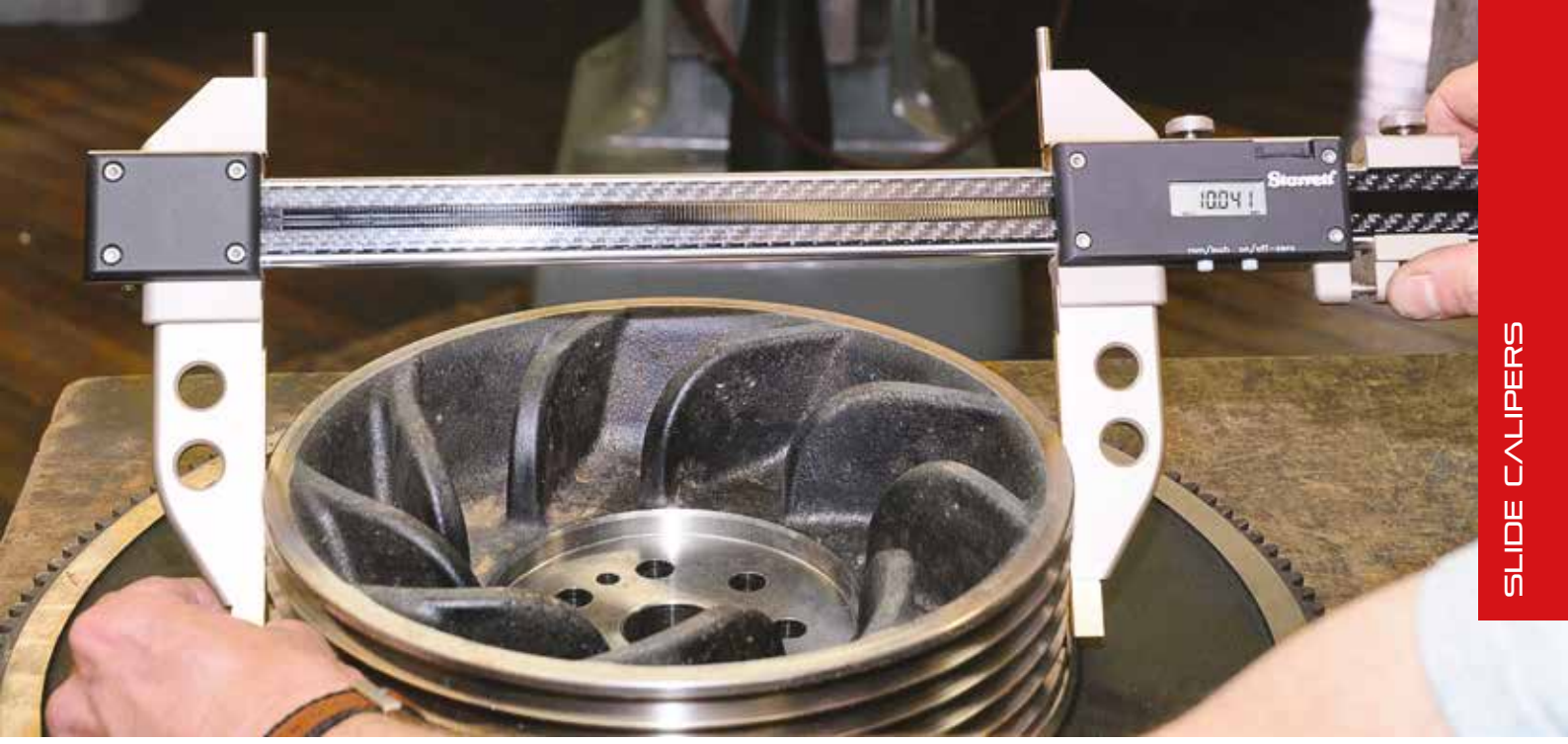

# CARBON FIBRE CALIPERS

## 5001 ELECTRONIC CARBON FIBRE CALIPERS

Starrett carbon fibre calipers are extremely light, comfortable and easy to use. IP67 protection makes these calipers suitable for use in workshop conditions exposed to coolant, water, dust or oil.

- Standard: DIN 862
- Titanium coated stainless steel outside measurement jaws for long life and superior flatness
- Two preset modes, REF I and REF II, allowing the set of one mode to a setting master and the second mode to a zero setting
- Metric / inch conversion
- Zero setting at any point
- Data output on 5001 series
- Manual / auto off after 30 minutes of non use
- Hold feature will freeze the display when in REF I or REF II mode
- Min/Max mode displays values referenced from the preset value of the REF mode the tool is in when entering MIN/MAX
- Tolerance mode to set upper and lower measurement tolerances



Cat No	Range	Resolution	Jaw Depth	Weight
C5001BZ-40/1000	0-1000mm / 0-40"	0.01mm / 0.0005"	150mm	2.5kg
D5001BZ-60/1500	0-1500mm / 0-60"	0.01mm / 0.0005"	2000mm	3.3kg
PT99492	3 Volt Battery CR2032			

## ELECTRONIC DEPTH GAUGES

### 3753A

#### ELECTRONIC DEPTH GAUGES

The 3753A Electronic depth gauge is a versatile, easy to use tool for measuring depth, slot widths and positions and lengths.

- Standard: Starrett factory specification
- Hardened stainless steel measuring surfaces
- Fine adjustment thumb wheel
- Lock screw for sliding base
- Hardened base measures 100mm (3-15/16"), with optional base extensions of 180mm (7-1/8"), 260mm (10-1/4") and 320mm (12-5/8")
- A hook attachment is supplied with the gauge, making it possible to take readings from the edge of slots, grooves and shoulders. The hook is removable if required
- Metric / inch conversion
- Zero set at any position
- Manual / auto off after 15 minutes of non use



3753A-6/150

3648-180 base extension

Cat No	Range	Resolution	Accuracy
3753A-6/150	150mm / 6"	0.01mm / 0.0005"	±0.03mm
3753A-8/200	200mm / 8"	0.01mm / 0.0005"	±0.03mm
3753A-12/300	300mm / 12"	0.01mm / 0.0005"	±0.03mm
3648-180	180mm base extension for 3753A and 3753B		
3648-260	260mm base extension for 3753A and 3753B		
3648-320	320mm base extension for 3753A and 3753B		
PT99492	3 Volts battery CR2032		

### 3753B

#### IP67 ELECTRONIC DEPTH GAUGES

The 3753B Electronic Depth Gauge features a large, easy-to-read, high contrast LCD readout. Its induction type linear encoder system includes IP67 protection against coolants, water, chips, dust and dirt often found in machine shop environments.

- Standard: Starrett factory specification
- Hardened stainless steel measuring surfaces
- Fine adjustment thumb wheel
- Lock screw for sliding base.
- Hardened base measures 100mm (3-15/16"), with optional base extensions of 180mm (7-1/8"), 260mm (10-1/4") and 320mm (12-5/8")
- A hook attachment is supplied with the gauge, making it possible to take readings from the edge of slots, grooves and shoulders. The hook is removable if required.
- Metric / inch conversion
- Zero set at any position
- Data output on 3753B series
- Manual / auto off after 30 minutes of non use



3753B-6/150

Cat No	Range	Resolution	Accuracy
3753B-6/150	150mm / 6"	0.01mm / 0.0005"	±0.03mm
3753B-8/200	200mm / 8"	0.01mm / 0.0005"	±0.03mm
3753B-12/300	300mm / 12"	0.01mm / 0.0005"	±0.03mm
PT99492	3 Volt battery CR2032		

# ELECTRONIC DEPTH GAUGES

## 5004 IP67 ELECTRONIC DEPTH GAUGES

The 5004 Long Range Electronic Depth Gauge features a large, easy-to-read, high contrast LCD readout. Its induction type linear encoder system includes IP67 protection against coolants, water, chips, dust and dirt often found in machine shop environments.

- Standard: Starrett factory specification
- Hardened stainless steel measuring surfaces
- Lock screw for sliding base
- Offset attachment available making it possible to take readings from the edge of slots, grooves, and shoulders.
- Optional movable base / bridge extensions available
- Metric / inch conversion
- Zero set any position
- Data output on 5004 series

Cat No	Range	Resolution	Accuracy
5004BZ-16/400	400mm / 16"	0.01mm / 0.0005"	±0.03mm
5004BZ-20/500	500mm / 20"	0.01mm / 0.0005"	±0.03mm
5004BZ-24/600	600mm / 24"	0.01mm / 0.0005"	±0.03mm

Cat No	Description
PT06133	400mm movable bridge attachment for use with 5004
PT06134	500mm movable bridge attachment for use with 5004
PT06135	600mm movable bridge attachment for use with 5004
PT99492	3 Volts battery CR2032

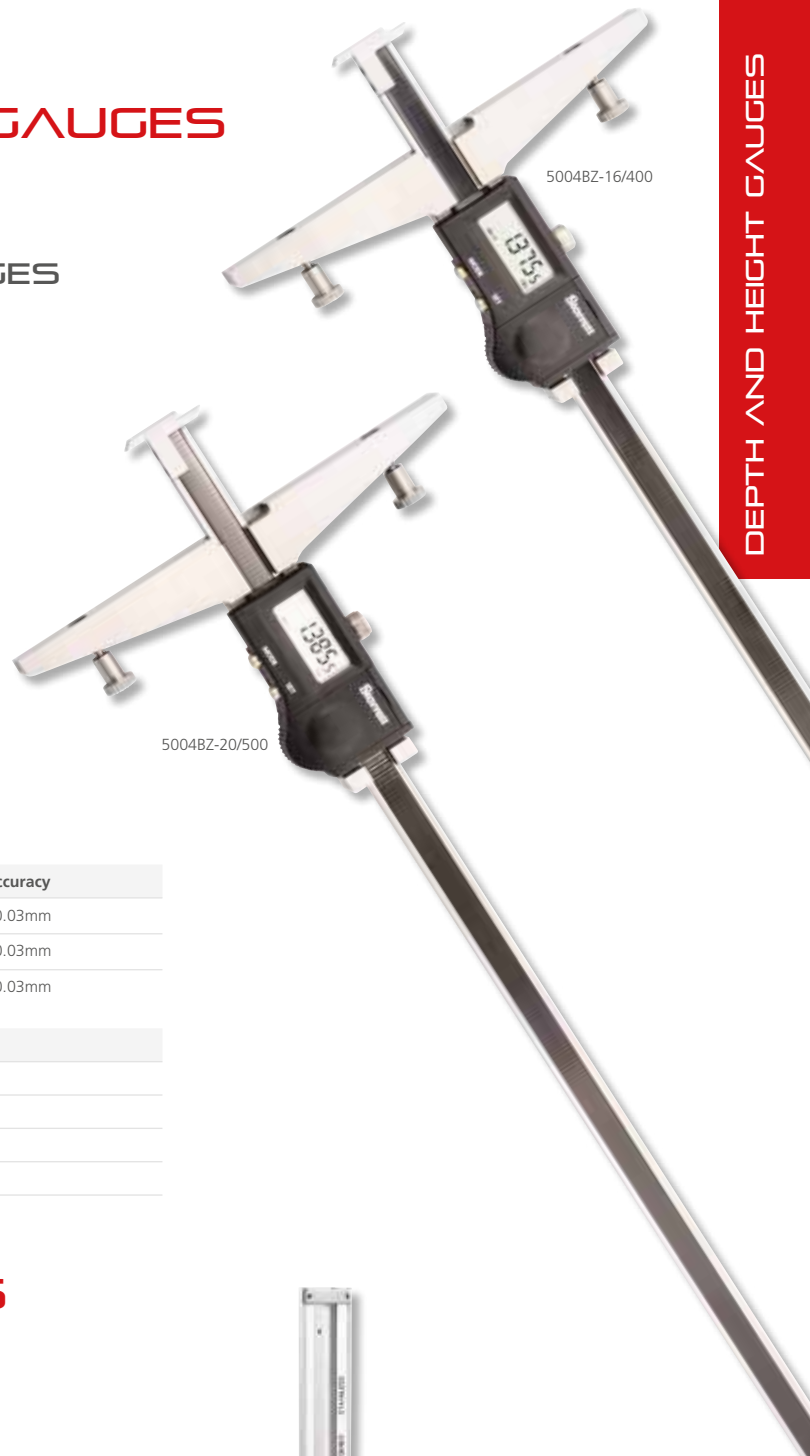

# DIAL HEIGHT GAUGES

## 3250 DIAL HEIGHT GAUGES

The compact 3250 Dial Height Gauge is a very useful tool for machinists and inspectors. Applications include scribing lines for layout, height and depth measurement (with optional attachment). It is simple to use, reliable, and accurate.

- Standard: Starrett factory specification
- Fine adjustment thumb roll for precision measurement
- Dial graduation 0.020mm or 0.001" (2mm or 0.100" movement per revolution)
- The auxiliary scribe has a rounded nose for cutting clean, sharp lines with smoothness and less pressure
- Hardened, stainless steel bar, rack, gears, scribe and scribe carrier
- Positive spring-loaded double pinion anti backlash control

Cat No	Range	Resolution	Accuracy
3250MZ-150	0-150mm	0.02mm	±0.03mm
3250Z-6	0-6"	0.002"	±0.001"
PT08680A	Depth attachment for 150mm height gauge		



## ELECTRONIC HEIGHT GAUGES

### 3751 ELECTRONIC HEIGHT GAUGE

This height gauge is light, portable and easy to use for vertical measurements within its range.

- Standard: Starrett factory specification
- Hardened stainless steel measuring surfaces
- Fine adjustment thumb roll for precision measurement
- Lock screw for setting fixed height position
- Hardened, ground, and lapped base with finger grooves provides ease of movement
- Scriber can reference zero from the bottom of the base to get full 150mm usable range
- Depth attachment (PT08680A) available for measuring of depth of holes, slots and recesses
- Metric / inch conversion
- Zero set at any position
- Manual / auto off after 5 mins of non use

Cat No	Range	Resolution	Accuracy
3751AZ-6/150	150mm/6"	0.01mm/0.0005"	±0.02mm
PT08680A	Depth attachment for 150mm height gauge		
PT99492	3 Volt battery CR2032		



3752-12/300

### 3752 ELECTRONIC HEIGHT GAUGES

The 3752 Electronic Height Gauge is a full featured, versatile and economic solution for most height measurement applications.

- Standard: Starrett factory specification
- Large positive action key pad
- Hardened stainless steel measuring surfaces
- Carrier and scriber designed to read from zero
- Metric / Inch conversion
- Zero set at any position
- Ability to retain and return to the true zero position
- Preset button to install any reading at any position
- "Hold" control feature retains a reading
- Plus or minus button to toggle polarity direction
- Minimum and maximum tolerance limits presetable
- Data output for 3752 series
- Manual / auto off after 30 mins of non use

Cat No	Range	Resolution	Accuracy
3752-12/300	0-300mm / 0-12"	0.01mm / 0.0005"	±0.04mm – 0-450mm
3752-24/600	0-600mm / 0-24"	0.01mm / 0.0005"	±0.05mm – 450mm-600mm
PT61120	3 Volt Battery CR2450 (2 required)		

# ELECTRONIC HEIGHT GAUGES

## 2000

### ALTISSIMO ELECTRONIC HEIGHT GAUGES



Altissimo® Electronic Height Gauges are innovative, easy-to-use, and loaded with Starrett exclusive functions for easy-to-program measuring routines that run smoothly and reliably.

- A unique, ergonomically shaped base, hardened and ground, that fits your grip just right to easily move the gauge and press the hot key
- Hot key allows you to select measuring results on the fly
- 0-600mm / 24" Measuring Range
- Smart probe that can measure I.D. or O.D. without attachments
- Electronically adjusted probe force
- Large, easy-to-read interactive LCD with unique scanning meter for monitoring probe position
- Electronically adjustable beeper volume
- Bold screen icons indicate the current routine
- Three electronically adjustable resolutions
- Retains the last calibrated diameter of the measuring probe, even after the gauge is shut down
- Dynamic bi-directional probing with point and scan modes
- Easy operation with speed wheel, which also has fine-adjust feature
- Locking mechanism for scribing
- Five measurement modes: (ID/OD, Centre, TIR, Max/Min, Continuous Display)
- Instant metric / inch conversion
- Two selectable Datums and Presets
- Auto Power Off after two hours with retention of probe calibration
- Automatic calculation of eight measurement routines:
  - Centre
  - Diameter
  - Height
  - Max
  - Min
  - TIR
  - Distance to last feature
  - Distance between last two points
- Rechargeable NiMH batteries with 100 hours of continuous life
- Seven setup functions:
  - Probe Calibration (2)
  - Beeper Volume
  - Display Resolution
  - Probe Force Adjustment
  - Printer On/Off
  - Force Calibration
- Optional probe kit features a variety of probes for many applications
- Gauges include carbide probe, probe holder and probe calibration block
- RS232 data output port
- Starrett capacitive measurement system ensures the accuracy and reliability you expect
- Excellent value – loaded with features and competitively priced

#### Specifications

Measuring Range	600mm / 24" (Extendible to 750mm/30" by rotating the probe holder 180°)
Resolution	0.001mm / .0001", 0.01mm / .0005", 0.02mm / .001"
Accuracy	±0.008mm / .0003"
Repeatability	±0.002mm / .0002"
Power Source	NiMH Rechargeable Batteries (120V AC/60Hz Charger/Adaptor included). Operation time: 100+ hours, Recharging time: 10 hours
Included	4.8mm / .1875" Dia. Carbide Probe, Probe Holder
Accessories	AC Charger / Adaptor, Probe Calibration Block
Dimensions	Length 279mm (11"), Width 197mm (7-3/4"), Height 927mm (36-1/2")
Weight	18kg (40 lb)
Perpendicularity	.0004" (0.010mm)

# ELECTRONIC HEIGHT GAUGES

## 2000

### ALTISSIMO ELECTRONIC HEIGHT GAUGES

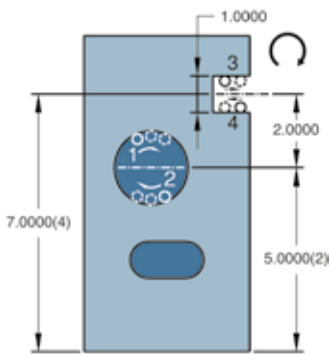

Altissimo includes many routines including diameter of a bore (1 and 2), width of a slot or a rib (3 and 4), distance from datum to centre of a hole or slot and distance between features

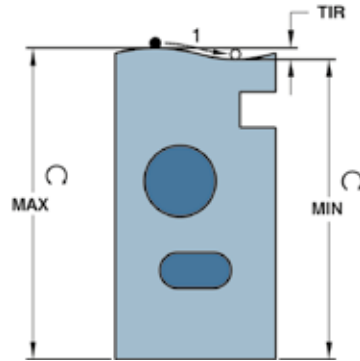

TIR mode can measure the high or low point of a diameter or other surface. The datum can then be set to the max or min value.

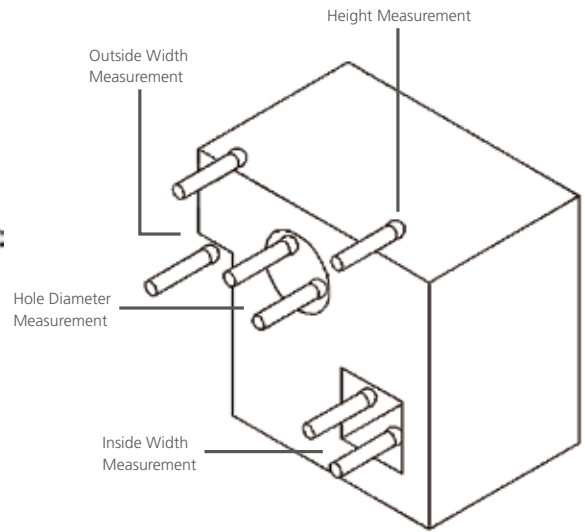

### ALTISSIMO ELECTRONIC HEIGHT GAUGES WITH STANDARD COMPONENTS

Description	Cat. No.
Height Gauge	2000-24
Carbide Probe 4.8mm (.1875") Dia. (Standard)	PT27937
Probe Holder (Standard)	PT27940
Probe Calibration Block (Standard)	PT27944



Large, easy-to-view /understand display shows the diameter of a hole or boss

### ACCESSORIES FOR ALTISSIMO ELECTRONIC HEIGHT GAUGES

Description	Part No.
Accessory Set Includes:	S2000AZ
Probe Tip, 5-Way Adaptor	PT27948
1mm (.040") Carbide Contact Point	PT23942
2mm (.078") Carbide Contact Point	PT23914
3mm (.120") Carbide Contact Point	PT23943
Contact Wrench	PT27952
10.2mm (.400") Cylindrical Probe	PT27945
Circular Carbide Scriber	PT27950
Depth Gauge Attachment	PT27949
Holder for Dovetail Indicators	PT27946
Replacement Battery Pack, NiMH 6V	PT62011
Power Supply Charger for USA and Canadian Configuration	PT62015
Power Supply Charger for United Kingdom Configuration	PT62130
Power Supply Charger for European Configuration	PT62131



Display showing TIR



Interactive LCD with unique scanning meter for easy probe position viewing

# OUTSIDE MICROMETERS

## 436

### OUTSIDE MICROMETERS

Precision micrometers used by skilled workmen worldwide. They are accurate, rugged and easy to use

- Standard: DIN 863
- Tungsten carbide measuring faces
- Starrett satin chrome finish for reduced glare and increased resistance to rust
- Advanced sleeve design with staggered lines and distinct figures for easy readability
- Balanced frame and thimble design ensure easy handling
- Ratchet controller giving uniform pressure and consistent measurements.
- Ring type lock nut for quick and sure locking
- Hardened one-piece spindle
- Spindle diameter of 6.35mm / .250" for micrometers up to 150mm and 7.62mm / .300" for micrometers above 150mm / 6"
- Complete with standard for 0-150mm / 0-6" individual micrometers



Cat No	Range	Resolution
436.2MXRL-25	0-25mm	0.01mm
436.1MXRL-50	25-50mm	0.01mm
436.1MXRL-75	50-75mm	0.01mm
436.1MXRL-100	75-100mm	0.01mm
436.1MXRL-125	100-125mm	0.01mm
436.1MXRL-150	125-150mm	0.01mm
436MXRL-175*	150-175mm	0.01mm
436MXRL-200*	175-200mm	0.01mm
436MXRL-225*	200-225mm	0.01mm
436MXRL-250*	225-250mm	0.01mm
436MXRL-275*	250-275mm	0.01mm
436MXRL-300*	275-300mm	0.01mm
234MB-150	150mm Setting Standard	
234MB-175	175mm Setting Standard	
234MB-200	200mm Setting Standard	
234MB-225	225mm Setting Standard	
234MB-250	250mm Setting Standard	
234MB-275	275mm Setting Standard	
V436.2MXRL-25	0-25mm	0.001mm
V436.1MXRL-50	25-50mm	0.001mm
V436.1MXRL-75	50-75mm	0.001mm
V436.1MXRL-100	75-100mm	0.001mm

Cat No	Range	Resolution
436.1XRL-1	0-1"	0.001"
436.1XRL-2	1-2"	0.001"
436.1XRL-3	2-3"	0.001"
436.1XRL-4	3-4"	0.001"
436.1XRL-5	4-5"	0.001"
436.1XRL-6	5-6"	0.001"
436XRL-7*	6-7"	0.001"
436XRL-8*	7-8"	0.001"
436XRL-9*	8-9"	0.001"
436XRL-10*	9-10"	0.001"
436XRL-11*	10-11"	0.001"
436XRL-12*	11-12"	0.001"
234B-6	6" Setting Standard	
234B-7	7" Setting Standard	
234B-8	8" Setting Standard	
234B-9	9" Setting Standard	
234B-10	10" Setting Standard	
234B-11	11" Setting Standard	
T436.1XRL-1	0-1"	0.0001"
T436.1XRL-2	1-2"	0.0001"
T436.1XRL-3	2-3"	0.0001"
T436.1XRL-4	3-4"	0.0001"

## 436

### OUTSIDE MICROMETER SETS WITH STANDARDS

Recommended for mechanics, automotive service and machine shops, toolrooms, inspection departments and wherever gauging involves a wide range of measurements. All sets come with attractive, protective cases which keep micrometers and setting standards together, and readily accessible

Cat No	Range	Resolution
S436.2MCXRLZ	0-150mm	0.01mm
S436MDXRLZ	150-300mm	0.01mm
S436MEXRLZ	0-300mm	0.01mm

Cat No	Range	Resolution
S436.1CXRLZ-1	0-6"	0.001"
S436DXRLZ	6-12"	0.001"
S436EXRLZ	0-12"	0.001"



S436.2MCXRLZ

# ELECTRONIC MICROMETERS

## 3732 & 733

### ELECTRONIC OUTSIDE MICROMETERS

The 3732 and 733 Electronic Outside Micrometers are built with customary Starrett quality and workmanship, including a large, easy to read, high contrast LCD digital display.

- Standard: DIN 863
- Tungsten carbide measuring faces
- Starrett satin chrome finish for reduced glare and increased resistance to rust
- Ratchet controller giving uniform pressure and consistent measurements
- mm graduation on shell and thimble with 6.35mm spindle diameter
- Ring type locking nut for quick and sure locking
- Hardened one-piece spindle
- Measurement HOLD button
- PRESET button to install any reading at any position
- Metric / Inch conversion
- Zero set at any position
- Data output for 733 series
- Manual / Auto off after 30 minutes of non-use
- Complete with setting standard



3732MEXFL-150



733MEXFLZ-100

Cat No	Range	Resolution
3732MEXRL-25	0-25mm / 0-1"	0.001mm / 0.00005"
3732MEXRL-50	25-50mm / 1-2"	0.001mm / 0.00005"
3732MEXRL-75	50-75mm / 2-3"	0.001mm / 0.00005"
3732MEXRL-100	75-100mm / 3-4"	0.001mm / 0.00005"
3732MEXRL-125	100-125mm / 4-5"	0.001mm / 0.00005"
3732MEXRL-150	125-150mm / 5-6"	0.001mm / 0.00005"
PT99492	3 Volt battery, CR2032	
Data Output	733-MEXRL-25	0-25mm / 0-1"
	733-MEXRL-50	25-50mm / 1-2"
	733-MEXRL-75	50-75mm / 2-3"
	733-MEXRL-100	75-100mm / 3-4"
	733-MEXRL-125	100-125mm / 4-5"
	733-MEXRL-150	125-150mm / 5-6"
PT61120	3 Volt Battery, CR2450	



733MEXFL-25



3732MEXFL-25



# ELECTRONIC OUTSIDE MICROMETERS

## 795 & 796

### IP67 ELECTRONIC OUTSIDE MICROMETERS

Starrett 796 and 795 IP67 Electronic Outside Micrometers feature a large, easy to read, high contrast LCD digital display. IP67 protection makes them suitable for use in workshop conditions exposed to coolant, water, dust, or oil.

- Standard: DIN 863
- Tungsten carbide measuring faces
- Starrett satin chrome finish for reduced glare and increased resistance to rust
- Ratchet controller giving uniform pressure and consistent measurements
- mm graduation on shell and thimble, 6.35mm spindle diameter
- Ring type locking nut for quick and sure locking
- Hardened one-piece spindle
- Measurement HOLD button
- PRESET button to install any reading at any position
- Metric / Inch conversion
- Zero set at any position
- Data output for 795 series
- Manual / Auto off after 30 minutes of non-use
- Complete with setting standard

Cat No	Range	Resolution
796XRL-1	0-25mm / 0-1"	0.001mm / 0.00005"
796XRL-2	25-50mm / 1-2"	0.001mm / 0.00005"
796XRL-3	50-75mm / 2-3"	0.001mm / 0.00005"
796XRL-4	75-100mm / 3-4"	0.001mm / 0.00005"
Data Output	795XRL-1	0-25mm / 0-1"
	795XRL-2	25-50mm / 1-2"
	795XRL-3	50-75mm / 2-3"
	795XRL-4	75-100mm / 3-4"
PT99492	3 Volt battery, CR2032	



### IP PROTECTION

An IP number is composed of two numbers, the first referring to protection against solid objects and the second against liquids.

**First number 6:** Totally protected against dust

**Second number 7:** Protection against submersion in water under standardised conditions of pressure for 30 minutes.

All 795 and 796 Micrometers include IP67 protection

# ANVIL MICROMETERS

## 224

### INTERCHANGEABLE ANVIL MICROMETERS

Each micrometer is equipped with a series of easily interchangeable anvils, thus providing the full range in steps of 25mm (1"). This makes 224 series micrometers very popular in machine or automotive repair shops.

- Standard: DIN 863
- Starrett satin chrome finish for reduced glare and increased resistance to rust
- Advanced sleeve design with staggered lines and distinct figures for easy readability
- Balanced frame and thimble design ensure easy handling
- Ratchet controller giving uniform pressure and consistent measurements
- Ring type lock nut for quick and sure locking
- Hardened one-piece spindle
- Rigid and stable special cast iron frame with appropriate perforations for lightness and ribbed for strength and stability
- Spindle diameter of 7.62mm / .30"
- Complete with setting standard

Cat No	Range	Resolution	Standards
224MAARLZ	0-100mm	0.01mm	25,50,75mm
224MARLZ	50-150mm	0.01mm	50,75,100,125mm
224MGRLZ	150-300mm	0.01mm	150,175,200,225,250,275mm
224MDRLZ	300-400mm	0.01mm	300,325, 350,375mm
224MERLZ	400-500mm	0.01mm	400,425,450,475mm
224MJRLZ	500-600mm	0.01mm	500,525,550,575mm
224AARLZ	0-4"	0.001"	1",2",3"
224ARLZ	2-6"	0.001"	2",3",4",5"
224BRLZ	6-9"	0.001"	6",7",8"
224GRLZ	6-12"	0.001"	6",7",8",9",10",11"
224CRLZ	9-12"	0.001"	9",10",11"
224DRLZ	12-16"	0.001"	12",13",14",15"
224ERLZ	16-20"	0.001"	16",17",18",19"
224JRLZ	20-24"	0.001"	20",21",22",23"



224MAARLZ

# CAN SEAM MICROMETERS

## 207 & 208

### CAN SEAM MICROMETERS

The 207 and 208 can seam micrometers are made of stainless steel and designed to measure the thickness and depth of can seams

- Standard: Starrett factory specification
- Balanced frame and thimble design ensure easy handling and better readability
- Friction thimble for uniform pressure and consistent measurements.
- Hardened one piece spindle
- Quick and easy adjustment

Cat No	Range	Resolution	Accuracy	Description
207MZ	0-9.5mm	0.01mm	±0.002mm	Snub nose for aerosol cans
208MZ	0-9.5mm	0.01mm	±0.002mm	Without depth gauge
208MDZ	0-9.5mm	0.01mm	±0.002mm	With depth gauge (5mm range)
207Z	0-0.375"	0.001"	±0.0001"	Snub nose for aerosol cans
208Z	0-0.375"	0.001"	±0.0001"	Without depth gauge
208DZ	0-0.375"	0.001"	±0.0001"	With depth gauge (0.2" range)



208MDZ

207MZ

# BLADE MICROMETERS

## 486

### BLADE MICROMETERS

The blade micrometer is designed for fast and accurate measurements of circular form tools, diameter and depth of narrow grooves, slots, keyways and recesses, and the depth between lands and fins

- Standard: DIN 863
- Starrett satin chrome finish for reduced glare and resistance to rust
- Advanced sleeve design with staggered line and distinct figures for easy readability
- Balanced frame and thimble design ensure easy handling
- Ratchet controller giving uniform pressure and consistent measurements.
- Hardened one-piece spindle
- Non rotating spindle
- The blade is 0.8mm / .030" thick and will measure to 8mm / 5/16" deep



486MP-25

Cat No	Range	Resolution
486MP-25	0-25mm	0.01mm
486MP-50	25-50mm	0.01mm
486MP-75	50-75mm	0.01mm
486MP-100	75-100mm	0.01mm
486P-1	0-1"	0.001"
486P-2	1-2"	0.001"
486P-3	2-3"	0.001"
486P-4	3-4"	0.001"

## 786

### ELECTRONIC BLADE MICROMETERS

786 Electronic blade micrometers feature a large, easy to read, high contrast LCD digital display, and are designed for fast and accurate measurements of circular form tools, diameter and depth of narrow grooves, slots, keyways and recesses, and the depth between lands and fins

- Standard: DIN 863
- Starrett satin chrome finish for reduced glare and increased resistance to rust
- Ratchet controller giving uniform pressure and consistent measurements.
- Hardened one-piece spindle
- Non rotating spindle
- Measurement HOLD button
- PRESET button to install any reading at any position
- Metric / Inch conversion
- Zero set at any position
- Data output for 786 series
- Manual / auto off after 30 minutes of non use



786MEP-100

Cat No	Range	Resolution
786MEP-25	0-25mm / 0-1"	0.001mm / 0.00005"
786MEP-50	25-50mm / 1-2"	0.001mm / 0.00005"
786MEP-75	50-75mm / 2-3"	0.001mm / 0.00005"
786MEP-100	75-100mm / 3-4"	0.001mm / 0.00005"
PT61120	3 Volt Battery, CR2450	

## DISC MICROMETERS

### 256

#### DISC MICROMETERS

256 disc micrometers are used to measure the thickness of work sections such as ribs, lands, fins, cutting edges on form tools, and chordal thickness of gear tool teeth.

- Standard: DIN 863
- Combination ratchet and speeder for uniform pressure and accurate measurements
- Anvil and spindle disc are 12.7mm / 1/2" diameter tapering to 0.4mm / .015" edge thickness making it possible to enter narrow grooves and recesses
- Hardened one piece spindle



256MRL-75

Cat No	Range	Resolution
256MRL-25	0-25mm	0.01mm
256MRL-50	25-50mm	0.01mm
256MRL-75	50-75mm	0.01mm
256RL-1	1-2"	0.001"
256RL-2	2-3"	0.001"
256RL-3	3-4"	0.001"

### 756

#### ELECTRONIC DISC MICROMETERS

The 756 electronic disc micrometer with a large, easy to read, high contrast LCD digital display is designed for fast and accurate measurements of thickness of work sections such as ribs, lands, fins, cutting edges on form tools, and chordal thickness of gear tool teeth.

- Standard: DIN 863
- Friction thimble for uniform pressure and accurate measurements
- Anvil and spindle disc are 12.7mm / 1/2" diameter tapering to 0.4mm / .015" edge thickness making it possible to enter narrow grooves and recesses
- Hardened one piece spindle
- Measurement HOLD button
- Metric / Inch conversion
- Zero set at any position
- Manual / auto off after 30 minutes of non use
- Data output on 756 Series



756MEFL-25

Cat No	Range	Resolution
756MEFL-25	0-25mm / 0-1"	0.001mm / 0.00005"
PT61120	3 Volt Battery, CR2450	

# INSIDE MICROMETER SETS

## 124

### SOLID-ROD INSIDE MICROMETER SETS

124 series are the most popular solid rod inside micrometer sets because of their lightness, ease of use, and range. They are useful for measuring inside diameters of cylinders and rings, measuring parallel surface, etc.

- Standard: DIN 863
- The desired range is obtained by assembling rods and spacing collars to the micrometer head
- Rod diameters are approx. 6mm / 1/4" on the A and B sizes, and approx. 8.5mm / 11/32" on the C size
- Measuring rods are solid and assembled on one side of the micrometer head
- Insulated rods marked with length
- Convenient handle is available to provide reach for use in deep holes. Handle screws into the micrometer head in place of the dummy screw, which is opposite a rod lock screw. Distance from the end of the handle to the centre line is 158mm / 6-1/4"



124MAZ

Cat No	Range	Resolution	Screw Movement	Measuring Rod	Spacing Collars
124MAZ	50-200mm	0.01mm	13mm	6	1 x 12mm
124MBZ	50-300mm	0.01mm	13mm	10	1 x 12mm
124MCZ	200-800mm	0.01mm	25mm	4	1 x 25mm and 2x50mm
124MDZ	50-800mm	0.01mm	Comprised of 124MA and 124MC		
124AZ	2-8"	0.001"	1/2"	6	1 x 1/2"
124BZ	2-12"	0.001"	1/2"	10	1 x 1/2"
124CZ	8-32"	0.001"	1"	4	1 x 1" and 2 x 2"
124DZ	2-32"	0.001"	Comprised of 124A and 124C		
124H	158mm length handle for 124 series				



## 823

### TUBULAR INSIDE MICROMETER SETS

The 823 micrometer is a highly useful tool for internal linear measurements such as measuring cylinders, rings, setting calipers, comparing gauges and measuring parallel surfaces.

- Standard: DIN 863
- Rod diameter is approx. 9.5mm / 3/8"
- Each rod is marked with length
- Interchangeable anvils on both 13mm and 25mm heads
- Lock nut furnished on 25mm heads
- 140mm length, convenient handle furnished on A,B,F micrometers may be clamped where it will provide correct balance and reach.



823w-2rods

Rods attachable as shown to either one or both ends of the head, ensuring the best balance, feel, and ease of reading.

Cat No	Range	Resolution	Screw Movement	Measuring Rod	Handle
823MAZ	40-200mm	0.01mm	13mm	6	Yes
823MBZ	40-300mm	0.01mm	13mm	8	Yes
823MEZ	100-1000mm	0.01mm	25mm	10	-
823AZ	1.1/2-8"	0.001"	1/2"	5	Yes
823BZ	1.1/2-12"	0.001"	1/2"	8	Yes
823CZ	4-24"	0.001"	1"	7	-
823DZ	4-32"	0.001"	1"	8	-
823EZ	4-40"	0.001"	1"	10	-
823FZ	1.1/2-32"	0.001"	1/2" and 1" (2 heads)	10	Yes



## DEPTH MICROMETERS

### 440 DEPTH MICROMETERS

440 depth micrometers for measuring the depth of holes, slots, shoulders and projections

- Standard: DIN 863
- Combination ratchet and speeder for uniform pressure and quicker adjustment
- Ring type locking nut for quick and sure locking

Cat No	Range	Resolution	Base	Rod	Rod Dia
440MZ-75RL	0-75mm	0.01mm	63.5mm	3	3.2mm
440MZ-150RL	0-150mm	0.01mm	63.5mm	6	3.2mm
440MZ-225RL	0-225mm	0.01mm	63.5mm	9	3.2mm
440Z-3L	0-3"	0.001"	2.1/2"	3	1/8"
440Z-6L	0-6"	0.001"	2.1/2"	6	1/8"
440Z-9L	0-9"	0.001"	2.1/2"	9	1/8"



440MZ-75RL



440MZ-75RL

## BENCH MICROMETER

### 777 ELECTRONIC BENCH MICROMETER

The 777 electronic bench micrometer is especially suited for precision measurement where the work must be brought to the gauge. Work is staged between the anvil and spindle on an adjustable table, which can be raised to a selected height and locked in position.

- Standard: DIN 863
- Hardened and ground and lapped one-piece spindle
- Tungsten carbide measuring faces
- Smooth friction thimble for uniform pressure and accurate readings
- Ring type locking nut for quick and sure locking
- Metric / Inch conversion
- Zero at any position and the ability to retain and return to the true zero reading of the micrometer
- PRESET button to install any set value at any position
- Ability to install minimum and maximum limits
- Manual / auto off after 30 minutes of non use
- Data output for 777 series



777MEXFLZ

Cat No	Range	Resolution
777MEXFLZ	0-25mm / 0-1"	0.001mm / 0.00005"
PT61120	3 Volt Battery, CR2450	

## HOLE GAUGES

### 829 & 831 SMALL HOLE GAUGES

- Hardened ball measuring surface with two point contact
- Radius on each gauge is less than the minimum diameter to be measured, which provides the two point contact necessary for maximum accuracy
- Accurate measurements are obtained by slightly "rocking" the gauge in the hole to be measured. This will guarantee contact at the true diameter. The final size is then obtained by measuring over the ball contacts with a micrometer
- 831 gauges can be used to check small shallow diameters

Cat No	Range	Approx. Length
829A	3.2-5.1mm/0.125-0.20"	75mm
829B	5.1-7.6mm/0.20-0.30"	80mm
829C	7.6-10.2mm/0.30-0.40"	85mm
829D	10.2-12.7mm/0.40-0.50"	90mm
S829EZ	Consisting of all 4, Range from 3.2-12.7mm/0.125-0.5"	
831A	3.2-5.1mm/0.125-0.20"	75mm
831B	5.1-7.6mm/0.20-0.30"	80mm
831C	7.6-10.2mm/0.30-0.40"	85mm
831D	10.2-12.7mm/0.40-0.50"	90mm
S831EZ	Consisting of all 4, range from 3.2-12.7mm/0.125-0.5"	



831  
Half ball  
gauging  
surface

829  
Full ball  
gauging  
surface



## TELESCOPING GAUGES

### 579 TELESCOPING GAUGES

- Handles are rigidly attached to the contact plungers and are automatically self-centring
- Constant spring tension gives uniform contact pressure
- The gauges must be slightly "rocked" in the hole to be measured to ensure that the gauge is on the proper diameter before it is locked. The final size is then obtained by measuring over the gauge contacts with a micrometer
- Handles longer than 60mm are available upon request

Cat No	Range	Handle Length
579A	8-13mm/ 5/16-1/2"	60mm
579B	13-19mm/ 1/2-3/4"	60mm
579C	19-32mm/ 3/4-1.1/4"	60mm
579D	32-54mm/ 1.1/4-2.1/8"	60mm
579E	54-89mm/ 2.1/8-3.1/2"	60mm
579F	89-150mm/ 3.1/2-6"	82mm
S579GZ	Consisting of 4 - A,B,C,D, range from 8-54mm/ 5/16-2.1/8"	
S579HZ	Consisting of 6 - A,B,C,D,E,F, range from 8-150mm/ 5/16-6"	



S579GZ

# DIAL BORE GAUGES

## 3089

### DIAL BORE GAUGES

- Standard: Starrett factory specification
- Ergonomic design, non slip grip and dial gauge protection shroud
- Tungsten carbide measuring faces
- Two point contact able to measure diameter, ovality and taper
- All anvils laser marked for easy selection



3089Z-131-26J



Cat No	Range	Resolution	Repeatability	Contacts	Spacers	Extension
3089M-181-10J	6-10mm	0.01mm	±0.01mm	9	-	-
3089M-181-18J	10-18mm	0.01mm	±0.01mm	9	1	-
3089M-181-35J	18-35mm	0.01mm	±0.01mm	9	2	-
3089M-181-50J	35-50mm	0.01mm	±0.01mm	4	4	-
3089M-181-160J	50-160mm	0.01mm	±0.01mm	12	4	1 x 55mm
S3089MZ-181-160J	18-160mm	0.01mm	Consisting of 3089M-181-35J,50J,160J			
3089M-181-250J	160-250mm	0.01mm	±0.01mm	5	5	1 x 50mm
3089M-181-450J	250-450mm	0.01mm	±0.01mm	5	5	1 x 50mm, 1 x 100mm
3089Z-131-715J	0.7-1.5"	0.0005"	±0.0005"	10	2	-
3089Z-131-1424J	1.4-2.4"	0.0005"	±0.0005"	6	4	-
3089Z-131-26J	2-6"	0.0005"	±0.0005"	11	4	1 x 2"
S3089Z-131-6J	0.7-6"	0.0005"	Consisting of 3089Z-131-715J,1424J,26J			

Extensions are available for bore gauges with range greater than 35mm.

Extension sizes: 250mm / 10", 500mm / 20", 1000mm / 40", 1500mm / 60" and 2000mm / 80"





# MECHANICAL BORE GAUGES

## 78

### MECHANICAL BORE GAUGES

- Standard: Starrett factory specification
- Precision ratchet controller giving uniform pressure and accurate measurements
- The gauges feature extended travel, reducing the need to exchange anvils
- The ground contact points seat the internal micrometer faster and more accurately than the spherical contacts found in other gauges
- 2-point contact for range up to 6mm / 1/4" only. 3-point contact from 6mm / 1/4" onward
- Tungsten carbide measuring faces above 12.5 mm diameter
- Blind bore measuring capability above 12.5mm / 1/2" diameter
- Extensions available from 63mm to 150mm / 2-1/2 - 6"
- Setting rings included, supplied with a calibration certificate
- Each mechanical bore gauge is supplied with a calibration certificate



BORE GAUGES

Cat No	Range	Resolution	Accuracy	Measuring Depth	Setting Ring Dia
78MXTZ-1.15	1-1.15mm	0.002mm	0.003mm	6mm	1mm
78MXTZ-1.3	1.15-1.3mm	0.002mm	0.003mm	6mm	1.3mm
78MXTZ-1.5	1.3-1.5mm	0.002mm	0.003mm	6mm	1.3mm
78MXTZ-1.75	1.5-1.75mm	0.002mm	0.003mm	8mm	1.75mm
78MXTZ-2	1.75-2mm	0.002mm	0.003mm	8mm	1.75mm
78MXTZ-2.5	2-2.5mm	0.005mm	0.004mm	9mm	2.5mm
78MXTZ-3	2.5-3mm	0.005mm	0.004mm	9mm	2.5mm
78MXTZ-4	3-4mm	0.005mm	0.004mm	12mm	4mm
78MXTZ-5	4-5mm	0.005mm	0.004mm	18mm	4mm
78MXTZ-6	5-6mm	0.005mm	0.004mm	18mm	5mm
78MXTZ-8	6-8mm	0.005mm	0.004mm	58mm	8mm
78MXTZ-10	8-10mm	0.005mm	0.004mm	58mm	8mm
78MXTZ-12.5	10-12.5mm	0.005mm	0.004mm	58mm	12.5mm
78MXTZ-16	12.5-16mm	0.005mm	0.004mm	62mm	12.5mm
78MXTZ-20	16-20mm	0.005mm	0.004mm	62mm	20mm
78MXTZ-25	20-25mm	0.005mm	0.004mm	66mm	20mm
78MXTZ-35	25-35mm	0.005mm	0.004mm	66mm	35mm
78MXTZ-50	35-50mm	0.005mm	0.004mm	80mm	35mm
78MXTZ-65	50-65mm	0.005mm	0.005mm	80mm	65mm
78MXTZ-80	65-80mm	0.005mm	0.005mm	80mm	65mm
78MXTZ-100	80-100mm	0.005mm	0.005mm	100mm	80mm
78MXTZ-125	100-125mm	0.005mm	0.006mm	115mm	125mm
78MXTZ-150	125-150mm	0.005mm	0.006mm	115mm	125mm
78MXTZ-175	150-175mm	0.005mm	0.007mm	115mm	175mm
78MXTZ-200	175-200mm	0.005mm	0.007mm	115mm	175mm
78MXTZ-225	200-225mm	0.005mm	0.008mm	118mm	225mm
78MXTZ-250	225-250mm	0.005mm	0.008mm	118mm	225mm
78MXTZ-275	250-275mm	0.005mm	0.009mm	118mm	275mm
78MXTZ-300	275-300mm	0.005mm	0.009mm	118mm	275mm

Cat No	Range	Resolution	Accuracy	No of heads	No of rings
S78MXTAZ	2-3mm	0.002mm	0.003mm	2	1
S78MXTBZ	3-6mm	0.002mm	0.004mm	3	2
S78MXTCZ	6-10mm	0.005mm	0.004mm	2	1
S78MXTDZ	10-20mm	0.005mm	0.004mm	3	2
S78MXT EZ	20-50mm	0.005mm	0.004mm	3	2
S78MXTFZ	50-100mm	0.005mm	0.004mm	3	2

Cat No	Range	Resolution	Accuracy	Measuring Depth	Setting Ring Dia
78XTZ-100	.080-.100"	0.0001"	.00010"	3/8"	.100"
78XTZ-120	.100-.120"	0.0001"	.00010"	3/8"	.100"
78XTZ-160	.120-.160"	0.0001"	.00010"	15/32"	.160"
78XTZ-200	.160-.200"	0.0001"	.00010"	3/4"	.160"
78XTZ-250	.200-.250"	0.0001"	.00010"	3/4"	.200"
78XTZ-312	1/4-5/16"	0.00025"	.00015"	2-1/4"	.3125"
78XTZ-375	5/16-3/8"	0.00025"	.00015"	2-1/4"	.3125"
78XTZ-500	3/8-1/2"	0.00025"	.00015"	2-1/4"	.500"
78XTZ-625	1/2-5/8"	0.00025"	.00015"	2-7/16"	.500"
78XTZ-750	5/8-3/4"	0.00025"	.00015"	2-7/16"	.750"
78XTZ-1	3/4-1"	0.00025"	.00015"	2-5/8"	.750"
78XTZ-138	1-1-3/8"	0.00025"	.00015"	2-5/8"	1.375"
78XTZ-2	1-3/8-2"	0.00025"	.00015"	3-1/16"	1.375"
78XTZ-258	2-2-5/8"	0.00025"	.00020"	3-1/16"	2.625"
78XTZ-314	2-5/8-3-1/4"	0.00025"	.00020"	3-1/16"	2.625"
78XTZ-4	3-1/4-4"	0.00025"	.00020"	4"	3.250"
78XTZ-5	4-5"	0.00025"	.00025"	4"	5.0"
78XTZ-6	5-6"	0.00025"	.00025"	4-1/2"	5.0"
78XTZ-7	6-7"	0.00025"	.00030"	4-1/2"	7.0"
78XTZ-8	7-8"	0.00025"	.00030"	4-1/2"	7.0"
78XTZ-9	8-9"	0.00025"	.00030"	4-1/2"	9.0"
78XTZ-10	9-10"	0.00025"	.00030"	4-5/8"	9.0"
78XTZ-11	10-11"	0.00025"	.00035"	4-5/8"	11.0"
78XTZ-12	11-12"	0.00025"	.00035"	4-5/8"	11.0"

Cat No	Range	Resolution	Accuracy	No of heads	No of rings
S78XTBZ	0.12-0.25"	0.00025"	0.00025"	3	2
S78XTCZ	1/4-3/8"	0.00025"	0.00025"	2	1
S78XTDZ	3/8-3/4"	0.00025"	0.00025"	3	2
S78XTEZ	3/4-2"	0.00025"	0.00025"	3	2
S78XTFZ	2-4"	0.00025"	0.00025"	3	2



# ELECTRONIC BORE GAUGES

## 780 IP65

### ELECTRONIC INTERNAL MICROMETERS

780XT IP65 Electronic Internal Micrometers are supplied with a high contrast LCD display for easy viewing, and IP65 level of protection, making them suitable for use in workshop conditions exposed to coolant, water, dust, or oil. They offer extended travel without the need to change anvils.

- Standard: Starrett factory specification
- Precision ratchet controller giving uniform measuring pressure and accurate readings
- The ground contact points seat the internal micrometer faster and more accurately than the spherical contacts found in other gauges
- 2-point contact for range up to 6mm / 1/4" only. 3-point contact from 6mm / 1/4" onward
- Tungsten carbide measuring faces on all gauges above 12.5mm / 1/2" diameter
- Blind hole measurement capacity above 12.5mm / 1/2"
- Metric / Inch conversion
- Presetable to size of master setting ring
- Data output for 780 series
- Extensions available from 63mm to 150mm / 2-1/2 - 6"
- Setting rings included, supplied with a calibration certificate
- Each mechanical bore gauge is supplied with a calibration certificate



780XTZ-138



Cat No	Range		Accuracy		Approx. Meas. Depth		Ring Diameter	
	mm	Inch	mm	Inch	mm	Inch	mm	Inch
780XTZ-100	2-2.5mm	.080-.100"			9mm	3/8"	2.54mm	.100"
780XTZ-120	2.5-3mm	.100-.120"						
780XTZ-160	3-4mm	.120-.160"	.004mm	.00015"	12mm	15/32"	4.06mm	.160"
780XTZ-200	4-5mm	.160-.200"					4.06mm	.160"
780XTZ-250	5-6mm	.200-.250"			18mm	3/4"	5.08mm	.200"
780XTZ-312	6-8mm	1/4 - 5/16"						
780XTZ-375	8-10mm	5/16 - 3/8"			58mm	2-1/4"	7.94mm	.3125"
780XTZ-500	10-12.5mm	3/8 - 1/2"					12.7mm	.500"
780XTZ-625	12.5-16mm	1/2 - 5/8"	.004mm	.00015"			12.7mm	.500"
780XTZ-750	16-20mm	5/8 - 3/4"			62mm	2-3/8"	19.05mm	.750"
780XTZ-1	20-25mm	3/4 - 1"					19.05mm	.750"
780XTZ-138	25-35mm	1 - 1-3/8"			66mm	2-5/8"		
780XTZ-2	35-50mm	1-3/8 - 2"			80mm	3-1/16"	34.93mm	1.375"
780XTZ-258	50-65mm	2 - 2-5/8"	.005mm	.00020"				
780XTZ-314	65-80mm	2-5/8-3-1/4"			80mm	3-1/16"	65.68mm	2.625"
780XTZ-4	80-100mm	3-1/4 - 4"	.005mm	.00020"	100mm	4"	82.55mm	3.250"
780XTZ-5	100-125mm	4 - 5"	.006mm	.00025"				
780XTZ-6	125-150mm	5 - 6"			115mm	4-1/2"	127.00mm	5.0"
780XTZ-7	150-175mm	6 - 7"	.007mm	.00030"				
780XTZ-8	175-200mm	7 - 8"			115mm	4-1/2"	177.80mm	7.0"
780XTZ-9	200-225mm	8 - 9"	.007mm	.00030"				
780XTZ-10	225-250mm	9 - 10"			118mm	4-5/8"	228.60mm	9.0"
780XTZ-11	250-275mm	10 - 11"	.009mm	.00035"				
780XTZ-12	275-300mm	11 - 12"			118mm	4-5/8"	279.40mm	11.0"
PT99492	3-volt Battery, CR2032 - two required							

# ELECTRONIC BORE GAUGES

## 781

### ACCUBORE ELECTRONIC BORE GAUGES SINGLE HANDED GAUGING OPERATION

- Simply squeeze the trigger, insert the gauge into the bore and released the trigger for an instant reading from the display
- True alignment with mechanically driven parallel anvils giving consistent measuring pressure with accurate measurements.
- 2-point contact for range up to 6mm / 1/4" only, 3-point contact from 6mm / 1/4" onward
- Tungsten carbide measuring faces on all gauges above 12.5mm / 1/2" diameter
- Blind hole measurement capacity above 12.5mm / 1/2"
- Metric / Inch conversion
- Presetable to size of master setting ring
- Data output for 781 series
- Specialised heads available for thread, groove and other non-standard measurement on request
- Setting rings included, supplied with a calibration certificate
- Each mechanical bore gauge is supplied with a calibration certificate

Cat No	Range	Resolution	Accuracy	Measuring Depth	Setting Ring Dia
781XTZ-100	2-2.5mm / .080-.100"	0.001mm / 0.00005	.004mm / .00015"	9mm	2.54mm / .100"
781XTZ-120	2.5-3mm / .100-.120"	0.001mm / 0.00005	.004mm / .00015"	9mm	2.54mm / .100"
781XTZ-160	3-4mm / .120-.160"	0.001mm / 0.00005	.004mm / .00015"	12mm	4.06mm / .160"
781XTZ-200	4-5mm / .160-.200"	0.001mm / 0.00005	.004mm / .00015"	18mm	5.08mm / .200"
781XTZ-250	5-6mm / .200-.250"	0.001mm / 0.00005	.004mm / .00015"	18mm	5.08mm / .200"
781XTZ-312	6-8mm / 1/4-5/16"	0.001mm / 0.00005	.004mm / .00015"	58mm	7.94mm / .3125"
781XTZ-375	8-10mm / 5/16-3/8"	0.001mm / 0.00005	.004mm / .00015"	58mm	7.94mm / .3125"
781XTZ-500	10-12.5mm / 3/8-1/2"	0.001mm / 0.00005	.004mm / .00015"	62mm	12.7mm / .500"
781XTZ-625	12.5-16mm / 1/2-5/8"	0.001mm / 0.00005	.004mm / .00015"	62mm	12.7mm / .500"
781XTZ-750	16-20mm / 5/8-3/4"	0.001mm / 0.00005	.004mm / .00015"	66mm	19.05mm / .750"
781XTZ-1	20-25mm / 3/4-1"	0.001mm / 0.00005	.004mm / .00015"	66mm	19.05mm / .750"
781XTZ-138	25-35mm / 1-1-3/8"	0.001mm / 0.00005	.004mm / .00015"	80mm	34.93mm / 1.375"
781XTZ-2	35-50mm / 1-3/8-2"	0.001mm / 0.00005	.004mm / .00015"	80mm	34.93mm / 1.375"
781XTZ-258	50-65mm / 2-2-5/8"	0.001mm / 0.00005	.005mm / .0002"	80mm	65.68mm / 2.625"
781XTZ-314	65-80mm / 2-5/8-3-1/4"	0.001mm / 0.00005	.005mm / .0002"	85mm	82.55mm / 3.250"
781XTZ-4	80-100mm / 3-1/4-4"	0.001mm / 0.00005	.005mm / .0002"	85mm	82.55mm / 3.250"
781XTZ-5	100-125mm / 4-5"	0.001mm / 0.00005	.006mm / .00025"	100mm	127.00mm / 5.0"
781XTZ-6	125-150mm / 5-6"	0.001mm / 0.00005	.007mm / .0003"	100mm	177.80mm / 7.0"
781XTZ-7	150-175mm / 6-7"	0.001mm / 0.00005	.007mm / .0003"	100mm	177.80mm / 7.0"
781XTZ-8	175-200mm / 7-8"	0.001mm / 0.00005	.007mm / .0003"	100mm	177.80mm / 7.0"
Cat No	Range	Resolution	No of heads	No of rings	
S781XTBZ	2-6mm / .080-.250"	0.001mm / 0.00005	5	3	
S781XTCZ	6-10mm / .250-.375"	0.001mm / 0.00005	2	1	
S781XTHZ	6-20mm / .250-.750"	0.001mm / 0.00005	5	3	
S781XTDZ	10-20mm / .375-.750"	0.001mm / 0.00005	3	2	
S781XTEZ	20-50mm / .750-2.00"	0.001mm / 0.00005	3	3	
S781XTJZ	20-100mm / .750-4.00"	0.001mm / 0.00005	6	4	
S781XTFZ	50-100mm / 2.00-4.00"	0.001mm / 0.00005	3	2	
S781XTKZ	100-150mm / 4.00-6.00"	0.001mm / 0.00005	2	1	
S781XTGZ	100-200mm / 4.00-8.00"	0.001mm / 0.00005	4	4	
S781XTLZ	150-200mm / 6.00-8.00"	0.001mm / 0.00005	2	1	
PT99492	3 Volt Battery, CR2032				



Output jack enables collection of measurement data for SPC analysis

BORE GAUGES

#### 781 PISTOL GRIP GAUGE ONLY WITH INDICATOR

- Without measuring head and ring

Cat No	Range
781XTP-250	2-6mm / 0.08-0.25"
781XTP-750	6-20mm / 1/4-3/4"
781XTP-4	20-100mm / 3/4-4"
781XTP-12	100-300mm / 4-12"

#### EXTENSIONS FOR 78, 780 AND 781 BORE GAUGES

Cat No	Model Size	Extension Size
78/782F	6-8mm / 1/4-5/16"	63mm
78/782G	10-12.5mm / 3/8-1/2"	75mm
78/782H	12.5-20mm / 1/2-3/4"	100mm
78/782J	20-50mm / 3/4-2"	150mm
78/782K	50-300mm / 2-12"	150mm



780XTZ-138

# BORE GAUGE HEADS

## SPECIAL BORE GAUGE MEASURING HEADS

We offer several configurations of special purpose measuring heads for 780, and 781 Bore Gauges, available by special order. Some, but not all, of these will also work with the 78 Bore Gauges.

### GROOVE MEASURING HEADS

- Groove. Available as a 2-point system for ovality measurement
- Various 2-point anvil forms available with diameters from 2-300mm / 080-12"
- Grooves. Available as a 3-point system
- Various 3-point anvil forms available for diameters from 6-300mm / .250-12"

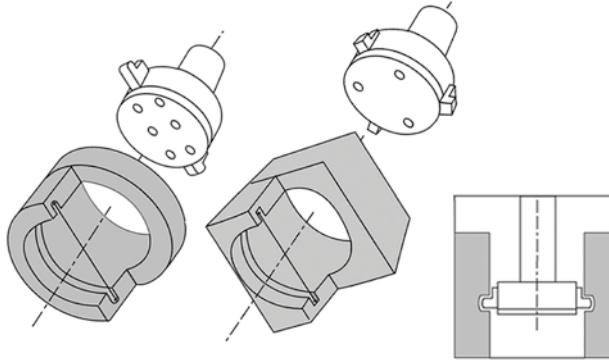

2-point and 3-point heads are available with various anvils to measure specialised internal grooves



### THREAD MEASURING HEADS

- Thread Measuring Heads are available as a two point system from M4-8mm / 8 to 5/16" and a three point system from 9.5-300mm / 3/8"-12". Most forms available including UNC, UNF, UNJ, UNS, Buttress, Acme, Multi-start, LH and RH
- Thread. Thread forms available as a 3-point system
- Internal. To measure effective (functional) diameter, pitch diameter
- Available as a two point system from M4-8mm / 8 to 5/16" Available as a three point system from 9.5-300mm / 3/8"-12"
- Most forms available including UNC, UNF, UNJ, UNS, Buttress, Acme, Multi-start, LH and RH

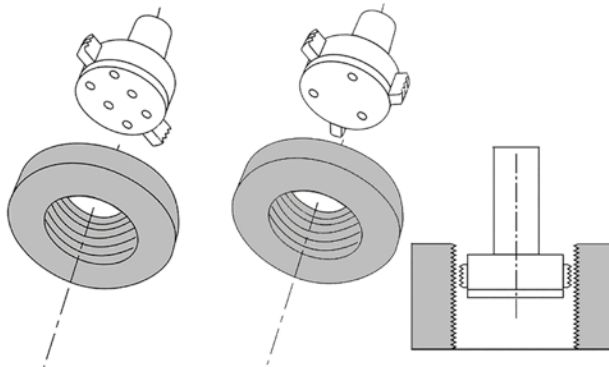

2-point and 3-point heads are available with various anvils to measure specialised internal grooves



### SPHERICAL RADIUS MEASURING HEADS

- Spherical Radius. Available as 2-point to measure ovality or with 3-point contact.
- Available with diameters from 6-100mm / .236-3.93"
- 3-Point Spherical. Available in 3-300mm / .118-12" range
- Gives good repeatability even when somewhat out of line with bore centre

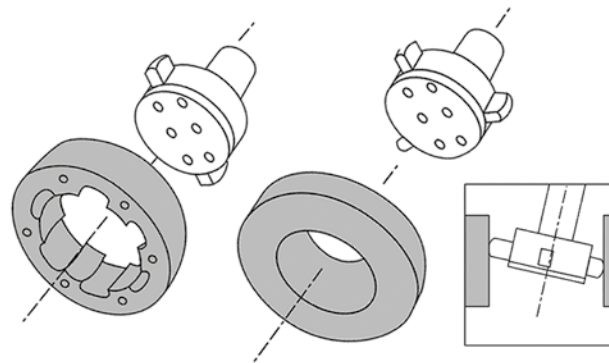

2-point and 3-point spherical radius heads are available



# BORE GAUGE SYSTEM

## ACCUPLUG BORE GAUGES

The Accuplug consists of interchangeable indicators, handles, plugs, extensions and depth stops for a custom bore gauge built specifically for your application needs.

- Ranges from 6-280mm / 0.2362-11.0236"
- M6 thread for 6-20mm / 0.2362-0.9843" plug. M10 thread for 15mm / 0.5906" onward
- 2 point measurement as standard for diameter ovality and taper measurements
- Repeatability  $\leq 0.001$ mm
- Setting by means of setting ring
- All setting rings supplied with UKAS calibration certificates
- Hard chrome plug body
- Tungsten carbide measuring contacts. Hard chrome, ruby or ceramic is available upon request.
- 802P plug as regular bore and 802BB plug for blind bore application



Accuplug	
Cat No	Range
802P-001	6-20mm / 0.2362-0.7874"
802P-002	15-25mm / 0.5906-0.9843"
802P-003	25-35mm / 0.9843-1.3780"
802P-004	35-45mm / 1.3780-1.7717"
802P-005	45-60mm / 1.7717-2.3622"
802P-006	60-80mm / 2.3622-3.1496"
802P-007	80-100mm / 3.1496-3.9370"
802P-008	100-125mm / 3.9370-4.9213"
802P-009	125-150mm / 4.9213-5.9055"
802P-010	150-175mm / 5.9055-6.8898"
802P-011	175-200mm / 6.8898-7.8740"
802P-012	200-225mm / 7.8740-8.8583"
802P-013	225-250mm / 8.8583-9.8425"
802P-014	250-280mm / 9.84-11.02"
Blind Bore	
802BB-001	6-20mm / 0.24"-0.79"
802BB-002	15-25mm / 0.5906-0.9843"
802BB-003	25-35mm / 0.9843-1.3780"
802BB-004	35-45mm / 1.3780-1.7717"
802BB-005	45-60mm / 1.7717-2.3622"
802BB-006	60-80mm / 2.3622-3.1496"
802BB-007	80-100mm / 3.1496-3.9370"
802BB-008	100-125mm / 3.9370-4.9213"
802BB-009	125-150mm / 4.92-5.91"

Setting Rings	
Cat No	Diameter Range
802RX-001	6-10mm / 0.236-0.394"
802RX-002	10-20mm / 0.394-0.787"
802RX-003	20-25mm / 0.7874-0.9843"
802RX-004	25-30mm / 0.9843-1.1811"
802RX-005	30-40mm / 1.1811-1.5748"
802RX-006	40-50mm / 1.5748-1.9685"
802RX-007	50-60mm / 1.9685-2.3622"
802RX-008	60-70mm / 2.3622-2.7559"
802RX-009	70-80mm / 2.7559-3.1496"
802RX-010	80-90mm / 3.1496-3.5433"
802RX-011	90-100mm / 3.5433-3.9370"
802RX-012	100-115mm / 3.9370-4.5276"
802RX-013	115-130mm / 4.5276-5.1181"
802RX-014	130-145mm / 5.1181-5.7087"
802RX-015	145-160mm / 5.7087-6.2992"
802RX-016	160-170mm / 6.2992-6.6929"
802RX-017	170-180mm / 6.6929-7.0866"
802RX-018	180-190mm / 7.0866-7.4803"
802RX-019	190-200mm / 7.4803-7.8740"
802RX-020	200-210mm / 7.8740-8.2677"
802RX-021	210-220mm / 8.2677-8.6614"
802RX-022	220-230mm / 8.6614-9.0551"
802RX-023	230-240mm / 9.0551-9.4488"
802RX-024	240-250mm / 9.4488-9.8425"
802RX-025	250-260mm / 9.8425-10.2362"
802RX-026	260-270mm / 10.2362-10.6299"
802RX-027	270-280mm / 10.63-11.02"



# BORE GAUGE SYSTEM

## ACCUPLUG BORE GAUGES

Depth Stop	
Cat No	Diameter Range
802DS-001	6-6.8mm / 0.236-0.335"
802DS-002	8.5-13mm / 0.335-0.512"
802DS-003	13-17.5mm / 0.5118-0.6890"
802DS-004	17.5-25mm / 0.6890-0.9843"
802DS-005	25-32.5mm / 0.9843-1.2795"
802DS-006	32.5-40mm / 1.2795-1.5748"
802DS-007	40-47.5mm / 1.5748-1.8701"
802DS-008	47.5-55mm / 1.8701-2.1654"
802DS-009	55-62.5mm / 2.1654-2.4606"
802DS-010	62.5-70mm / 2.4606-2.7559"
802DS-011	70-77.5mm / 2.7559-3.0512"
802DS-012	77.5-85mm / 3.0512-3.3465"
802DS-013	85-92.5mm / 3.3465-3.6417"
802DS-014	92.5-100mm / 3.642-3.937"

Holders	
Cat No	Description
802H6-001	M6 holder short 3/8" stem
802H6-002	M6 holder long 3/8" stem
802H6-003	M6 holder short 8mm stem
802H6-004	M6 holder long 8mm stem
802E6-001	M6 100mm extension
802H10-001	M10 holder short 3/8" stem
802H10-002	M10 holder long 3/8" stem
802H10-003	M10 holder short 8mm stem
802H10-004	M10 holder long 8mm stem
802E10-001	M10 100mm extension



Indicators						
Cat No	Range	Resolution	Repeatability	Hysteresis	Accuracy	Stem Dia
647M	0.1mm	0.001mm	±0.0002mm	±0.0033mm	± 1 Graduation	8mm
647	0.004"	0.00005"	±0.000008"	±0.00001"	± 1 Graduation	3/8"
F2720ADM	15mm/0.6"	0.001mm / 0.00005"	±0.002mm			8mm
2900-4ME	12mm/0.5"	0.001mm / 0.00005"	±0.003mm			8mm

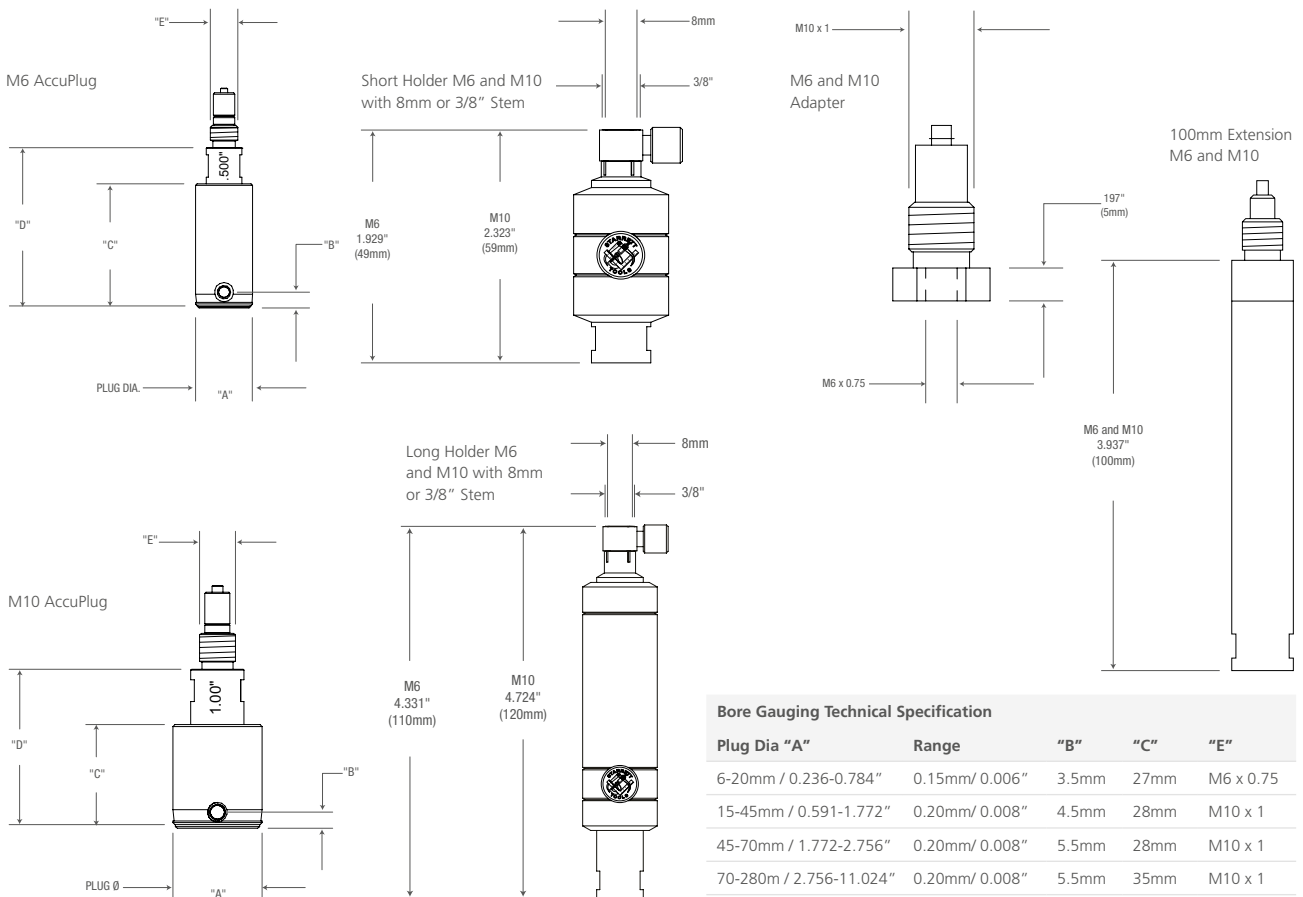

## INDICATORS

### 3081, 3025 & 3089 MECHANICAL DIAL INDICATORS

- Standard: DIN 878
- Precision gears and pinions
- Upper protective cap on measuring spindle
- Adjustable tolerance markers and bezel lock

Cat No	Range	Resolution	Stem Dia	Dial Reading	Dial Face
3081-481/5	5mm	0.01mm	8mm	0-100	43mm
3025-481/5	5mm	0.01mm	8mm	0-100	57mm
3025-481	10mm	0.01mm	8mm	0-100	57mm
3025-681	20mm	0.01mm	8mm	0-100	57mm
3025-257J	1mm	0.001mm	8mm	0-200	57mm
3089SEA	0.25"	0.0005"	3/8"	0-50	2.1/4"



### 647 MECHANICAL DIAL COMPARATORS

- Standard: Starrett factory specification
- Effective non-shock mechanism
- Pinions and shaft of the movement are jewelled
- Safety cap prevents unintentional turning of the fine adjustment screws

Cat No	Range	Resolution	Repeatability	Hysteresis	Accuracy	Dial Reading	Stem Dia
647M	0.1mm	0.001mm	±0.0002mm	±0.0033mm	±1 graduation	50-0-50	8mm
647	0.004"	0.00005"	±0.000008"	±0.00001"	±1 graduation	20-0-20	3/8"



# INDICATORS

## 3808, 3908, 3809 & 3909 MECHANICAL TEST INDICATORS

- Standard: DIN 2270
- Precision gear driven design with smooth, jewelled movement
- Frictionally adjustable contact point reverses automatically, always maintaining clockwise hand specification
- All items with cat no. ending 'A' are supplied with 9.5mm and 4mm dovetail clamps – 2 attachments
- All items with cat no ending 'AC' are supplied with 9.5mm and 4mm dovetail clamps, 4mm swivel post holder, tool post holder, universal snivel and post assembly – 6 attachments



3808MAC



3808MA

Cat No	Range	Resolution	Dial Reading	Dial Face
3809MA	0.8mm	0.01mm	0-40-0	40mm
3809MAC	0.8mm	0.01mm	0-40-0	40mm
3909MA	0.8mm	0.01mm	0-40-0	32mm
3909MAC	0.8mm	0.01mm	0-40-0	32mm
3808MA	0.2mm	0.002mm	0-100-0	40mm
3808MAC	0.2mm	0.002mm	0-100-0	40mm
3908MA	0.2mm	0.002mm	0-100-0	32mm
3908MAC	0.2mm	0.002mm	0-100-0	32mm
3809A	0.030"	0.0005"	0-15-0	1.1/4"
3809AC	0.030"	0.0005"	0-15-0	1.1/4"
3909A	0.030"	0.0005"	0-15-0	1.9/16"
3909AC	0.030"	0.0005"	0-15-0	1.9/16"
3808A	0.008"	0.0001"	0-4-0	1.1/4"
3808AC	0.008"	0.0001"	0-4-0	1.1/4"
3908A	0.008"	0.0001"	0-4-0	1.9/16"
3908AC	0.008"	0.0001"	0-4-0	1.9/16"





# ELECTRONIC INDICATORS

## 3600 ELECTRONIC INDICATOR

- Standard: Starrett factory specification
- Reverse travel ( $\pm$  control indicates direction)
- Metric / Inch conversion
- Zero at any spindle position
- Upper protective cap on measuring spindle
- 8mm / 5/16" diameter stem with M2.5 x 0.45 spindle thread

Cat No	Range	Resolution	Accuracy
3600M-5	12.5mm / 0.5"	0.01mm / 0.0005"	$\pm 0.03$ mm
PT61918	SR44 Battery		



## 2700 WISDOM ELECTRONIC INDICATORS

- Standard: Starrett factory specification
- Plus or minus travel direction
- Metric / Inch conversion
- Zero at any spindle position
- Rotating bezel
- 'IQM' models include 'programmable ratios' capability
- Data output for 2700 series
- Auto off after 10 minutes of non-use

Cat No	Range	Resolution	Accuracy
F2730IQM	25mm / 1"	0.001mm / 0.00005"	$\pm 0.002$ mm
F2740IQM	50mm / 2"	0.002mm / 0.0001"	$\pm 0.004$ mm
F2750IQM	100mm / 4"	0.002mm / 0.0001"	$\pm 0.004$ mm
F2720ADM	15mm / 0.6"	0.001mm / 0.00005"	$\pm 0.002$ mm
F2730ADM	25mm / 1"	0.001mm / 0.00005"	$\pm 0.002$ mm
F2740ADM	50mm / 2"	0.002mm / 0.0001"	$\pm 0.004$ mm
F2750ADM	100mm / 4"	0.002mm / 0.0001"	$\pm 0.004$ mm
PT61120	3 Volt Battery, CR2450 (2 required)		



## 2900 IP67 ELECTRONIC INDICATORS

- Standard: Starrett factory specification
- Plus or minus travel direction
- Metric / Inch conversion
- Zero at any spindle position
- Selectable resolution models available.
- Data output for 2900 series
- IP67 protection
- Manual / auto off after 10 minutes of non use

Cat No	Range	Resolution	Accuracy
2900-1ME	12mm / 0.5"	0.001mm / 0.00005"	$\pm 0.003$ mm
2900-4ME	12mm / 0.5"	0.001mm / 0.00005"	$\pm 0.003$ mm
2900-6ME	12mm / 0.5"	0.001mm / 0.00005"	$\pm 0.003$ mm
PT99492	3 Volt Battery, CR2032 (2 required)		



### FEATURES FOR 2700 AND 2900 ELECTRONIC INDICATORS

Functions	F2730IQM	F2730IQM	F2730IQM	F2720ADM	F2730ADM	F2740ADM	F2750ADM	2900-1ME	2900-4ME	2900-6ME
Resolution	0.001mm / 0.00005"							X		
	0.01mm / 0.001mm / 0.0005" / 0.0001" / 0.00005"							X X		
	0.02mm / 0.01mm / 0.0002mm / 0.0001mm / 0.001" / 0.0005" / 0.0001" / 0.00005"							X X X		
	0.02mm / 0.01mm / 0.002mm / 0.001" / 0.0005" / 0.0001"							X X X		
Origin set, Zero Set	X	X	X	X	X	X	X	X	X	X
Counting Direction Switching (±)	X	X	X	X	X	X	X	X	X	X
SPC Output	X	X	X	X	X	X	X	X	X	X
Limit Set	X	X	X	X	X	X	X		X	X
Value Preset	X	X	X	X	X	X	X		X	X
Reading Hold	X	X	X	X	X	X	X		X	X
Feature lock	X	X	X	X	X	X	X		X	X
Max/Min/Runout Value Holding	X	X	X	X	X	X	X		X	X
TIR Runout Value Holding	X	X	X	X	X	X	X			X
IP67 Protection								X	X	X
True Absolution Sensor Tech		X	X	X	X	X	X	X	X	X
Programmable Ratio	X	X	X							
Lug on Centre	X	X	X	X	X	X	X	X	X	X

# BACK PLUNGER INDICATORS

## 196

### UNIVERSAL BACK PLUNGER DIAL INDICATORS

- Standard: Starrett factory specification
- Smooth and accurate operation
- Shank diameter is 6.3mm / 1/4"
- \*196A6Z and 196B6 are anti-magnetic

Cat No	Range	Resolution	Accuracy	Dial Reading	Contents
196MA1Z	5mm	0.02mm		0-100	1,2,3,4,A,B,C,G in case
196MB1	5mm	0.02mm		0-100	1,2,3,4 only
196MA5Z	5mm	0.02mm		0-50-0	1,2,3,4,A,B,C,G in case
196MB5	5mm	0.02mm	±0.02mm/ ±0.001" (one graduation) any- where on dial	0-50-0	1,2,3,4 only
196A1Z	0.2"	0.001"		0-100	1,2,3,4,A,B,C,G in case
196B1	0.2"	0.001"		0-100	1,2,3,4 only
*196A6Z	0.2"	0.001"	Hysteresis-1 graduation	0-100	1,2,3,4,A,B,C,G in case
*196B6	0.2"	0.001"		0-100	1,2,3,4 only
194A5Z	0.2"	0.001"		0-50-0	1,2,3,4,A,B,C,G in case
196B5	0.2"	0.001"		0-50-0	1,2,3,4 only

Cat No	Description	Ref No	Cat No	Description	Ref No
196MR	Adapter (mm thread)	1	PT18718	Snug complete	C
196R	Adapter (4-48 thread)	2	PT18724	Snug complete - 1/4" and 3/8" hole	D
PT05471	Hardness steel contact point	3	57S	Universal snug	E
PT05472	Hardness steel contact point	4	58S	Universal snug	F
PT05473	Hardness steel contact point	5	196F	Hole attachment for 196 and 196M only	G
PT99437	Clamp	A	PT08726A	Shock absorbing anvil for 196 and 196M only	H
PT99438	Tool post holder	B	PT00764	Split bushing for 196 and 196M only	I



### ATTACHMENTS FOR 650, 651, 196 AND 196M BACK PLUNGER DIAL INDICATORS AND UNIVERSAL DIAL INDICATORS

- A. Clamp PT99437 With a 33mm / 1-5/16" flat or round capacity - 8mm / 5/16" post (PT03709-1/2) used with PT18718 Snug
- B. Tool Post Holder PT99438 9.5 x 19 x 150mm / 3/8" x 3/4" x 6" with upright spindle (PT03820-0) 8 dia. x 114mm length / 5/16" x 4-1/2". Use with PT18718 Snug
- C. Snug Complete PT18718. Post hole has an 8mm / 5/16" diameter and 2.4 - 6.3 mm / 3/32-1/4" holding capacity. Can be used on our 252 Height Transfer Gauge, 57 and 257A and B Surface Gauges, on 657A Magnetic Base and Swivel Post Assembly
- D. Snug Complete PT18724. Post hole has a 9.5mm / 3/8" diameter and 2.4-6.3mm / 3/32-1/4" holding capacity. Can be used with our 57 and 257C and D Surface Gauges or 657AA Magnetic Base with upright post

- E. Universal Snug 57S With spindle hole diameters 8, 9.5mm / 5/16", 3/8" and gripping hole diameters 3.5, 4, 4.8, 6.3mm / 9/64", 5/32", 3/16", 1/4"
- F. Universal Snug 58S. With spindle hole diameters 6.3, 8, 9.5mm / 1/4", 5/16", 3/8". Gripping hole diameters range from 2.4-6.3mm / 3/32-1/4" used on holders with smaller clamp hole

### ATTACHMENTS FOR 196 AND 196M ONLY

- G. Hole Attachment 196F. allows indicator to be used over obstructions and inside holes to a depth of approximately 40mm / 1-5/8"
- H. Shock Absorbing Anvil PT08726A
- I. Split Bushing PT00764. Allows attachment of 196 Indicator to 660 Magnetic Base

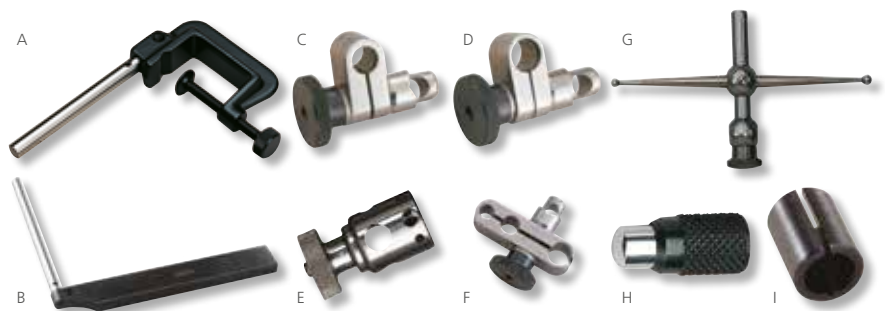

## SPECIAL FUNCTION INDICATORS

### 3015

#### PORTABLE DIAL THICKNESS GAUGES

- Standard: Starrett factory specification
- Lever to lift upper measuring spindle
- With flat measuring surface

Cat No	Range	Resolution	Accuracy	Dial Reading	Throat depth
3015MA	10mm	0.01mm	±0.03mm	0-100	63mm
3015A	0.5"	0.001"	+0.001"	0-50	2.5"



### 765A

#### ELECTRONIC SNAP GAUGE

- Standard: Starrett factory specification
- Single handed snap gauge measurements
- Metric / Inch conversion
- Zero at any position
- Manual / Auto off after 30mins non use

Cat No	Range	Resolution	Accuracy
765A	0-12.7mm/0-0.5"	0.01mm/0.0005"	±0.02mm / .001"
PT99492	3 Volt Battery, CR2032		



### 682EMZ

#### SAW TENSION GAUGE

- The Saw Tension Gauge will check for proper blade tension in metric or imperial, and is graduated in kilogrammes and pounds
- The tension gauge can be read directly on band saws of any type, or power hacksaws
- It is graduated to read up to 4,000kg per cm<sup>2</sup> or 60,000 PSI and is supplied with instructions, including suggested tensions

Cat No	Description
682EMZ	Saw tension gauge

682EMZ



# SPECIAL FUNCTION INDICATORS

## 696

### CRANKSHAFT DISTORTION DIAL/STRAIN GAUGES

An ideal gauge for checking bearing alignment or shaft deflection without dismantling the engine. Also useful as a strain gauge on engine frames. This inside measuring gauge checks the distortion of crankshaft webs and bears a direct relation to existing misalignment or excessive bearing wear. Used on all diesel engine shafts and centre crankshafts on any type of engine or compressor, the gauge can also be applied as a strain gauge on engine frames while the engine is operating. A comparison of readings taken at top and bottom positions indicates any misalignment of cylinder and frame which results in local over-stress and eventual cracking of the frame neck.

With a special spring tension in the dial indicator, the gauge is self-sustaining in any position without sacrificing necessary rigidity, leaving the operator's hands free. Hardened and ground to a sharp point, conical contact points have an approximate 60° included angle, and will stay in place on 45° surfaces.

FIG. 1

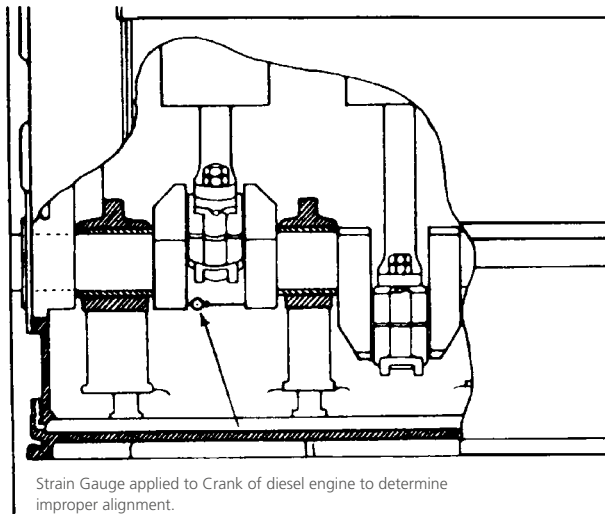
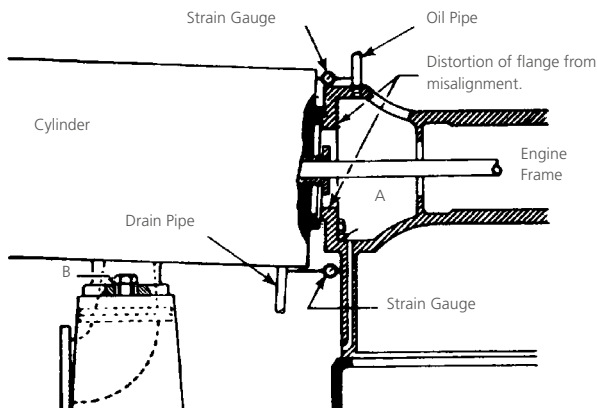

FIG. 3



Misalignment of cylinder and engine frame (shown exaggerated for purposes of illustration).



696MZ

Cat No	Range	Resolution	Dial Reading	Range One Rev
696MZ	61-458mm	0.02mm	0-50-0	1mm
696Z	2.3/8-18"	0.001"	0-20-0	0.040"
696B	Balancing attachment only			

FIG. 2

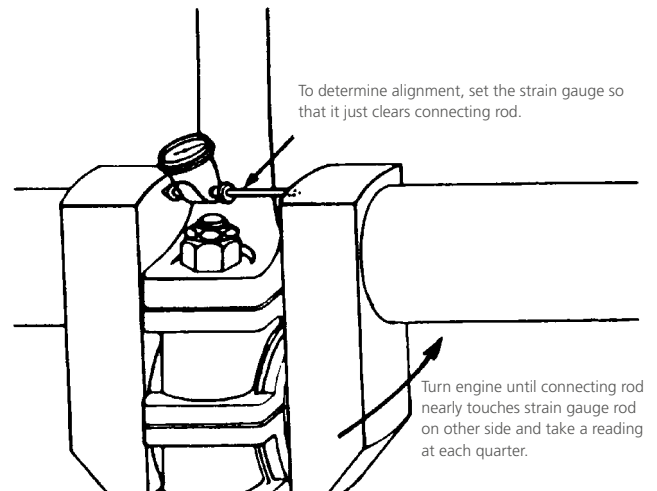
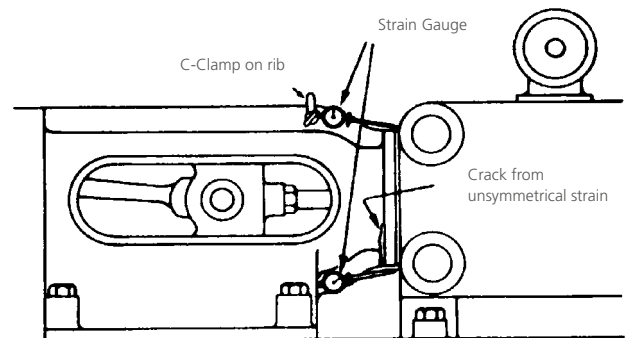

FIG. 4



Strain Gauge applied to engine frame (while operating), difference between top and bottom readings of the strain gauge indicates improper alignment, causing cracks.

## INDICATOR HOLDERS / STANDS

- The compact and versatile **660** magnetic base indicator holder has 3 adjustable pivots controlled by a single knob for fast, easy indicator positioning
- The **661** mini magnetic tool holder is a simple, versatile, effective and economical tool for a verity of indicator holder task
- The rigid design **3657AA** magnetic base indicator holder has a support arm with one joint and with fine adjustment
- The **3657MTW** flex-o-post indicator holder with magnetic base is an assembly of short tubular steel sections and precision ball joints, linked by an internal steel cable. It can be adjusted to any position and locked by turning a level near the magnetic base
- The versatile **3670** series dial gauge stands feature a strong and rigid parallel spring assembly, adjustable support arm for indicator and fine adjustment
- The **3206** outside micrometer stand converts an outside micrometer to a study bench gauge for batch inspection of small parts. The ball joint construction allows the head to be positioned as much as 30° off perpendicular in any direction.



Cat No	Description	Dimension
660M	Magnetic stand with articulating arm, 8mm stem hole. 320N holding force	36 x 30 x 35mm Base with overall height of 200mm
661M	Mini magnetic stand with 6mm and 8mm stem hole. 170N holding force	30mm dia. Base with overall height of 103mm
3657AA	Magnetic stand with find adjustment, 3/8" and 8mm stem hole. 800N holding force	63 x 55 x 50mm Base with overall height of 230mm
3657MTW	Flex O post magnetic stand with fine adjustment. 800N holding force	67 x 50 x 55mm base with overall height of 352mm
3671	Stand with 60mm dia. flat anvil 3/8" stem hole and 8mm bushing with fine adjustment. Flatness of 0.0013mm	184 x 126 x 50mm base with 190mm Column height
3672	Stand with 60mm dia. serrated anvil 3/8" stem hole and 8mm bushing with fine adjustment. Flatness of 0.0013mm	184 x 126 x 50mm base with 190mm Column height
3673	Stand with 90 x 90mm square anvil 3/8" stem hole and 8mm bushing with fine adjustment. Flatness of 0.0013mm	184 x 126 x 50mm base with 190mm Column height
3206	Outside micrometer stand	162 x 89 x 19mm base with tilting head capacity of 19mm thickness x 25mm throat depth

# FIXED GAUGES

## TAPER GAUGES

- Specification: Starrett factory standard
- 267 series for checking of inside diameters of tubing, general gauging of slot widths, hole sizes, etc.
- 270 series for bearing work and gauging slots
- 269 series for determining hole sizes in die and all kinds of other work



Cat No	Leaves	Range	Reading	Accuracy	Length
267	3	1/16" - 1.1/16"	64 <sup>th</sup>	±0.001"	1" x 5.1/4"
270	3	0.3-4mm/ 0.01"-0.15"	0.05mm/ 0.001"	±0.013mm/ ±0.0005"	11 x 160mm
269MA	10	2-12mm	0.02mm	±0.013mm	64mm
269MB	13	12-25mm	0.02mm	±0.013mm	70mm
269A	8	0.1-0.5"	0.001"	±0.0005"	2.1/2"
269B	10	0.5-1.0"	0.001"	-/0.0005"	2.3/4"

## THICKNESS GAUGES

These gauges are used in automotive, aviation, diesel and farm equipment manufacture and service and also in jig, fixture, gauge and experimental work.

- Specification: Starrett factory standard (available upon request)
- Leaves made of finest tempered-steel, marked with thickness
- Metric and Imperial thickness gauges range from 0.03mm to 5mm / 0.0015" to 0.2"
- Straight and tapered leaves









Cat No	Leaves	Range (leave thickness)	Accuracy	Size Leaves	Description
<b>Inch Reading Thickness Gauges with Straight Leaves</b>					
172A	9	.0015, .002, .003, .004, .006, .008, .010, .012, .015		1/2 x 3-1/32"	
66	26	.0015, .002, .0025, .003, .004, .005, .006, .007, .008, .009, .010, .011, .012, .013, .014, .015, .016, .017, .018, .019, .020, .021, .022, .023, .024, .025		1/2 x 3-1/32"	
66B	31	.0015, .002, .0025, .003, .004, .005, .006, .007, .008, .009, .010, .011, .012, .013, .014, .015, .016, .017, .018, .019, .020, .021, .022, .023, .024, .025, .026, .028, .030, .032, .035		1/2 x 3-1/32"	
467	13	.0015, .002, .003, .004, .006, .008, .010, .020, .030, .040, .075, .100, .200	.001-.007" ±.0002" .008-.009 ±.00025" .010-.012" ±.00035"	1/2 x 4-1/2"	Straight leaves with Locking Device
172E	8	.002, .003, .004, .005, .006, .008, .010, .015		1/2 x 12"	
572A	22	.0015, .002, .0025, .003, .004, .005, .006, .007, .008, .009, .010, .012, .013, .014, .015, .016, .018, .020, .022, .025, .030, .035 6 Spark Plug Wire Gauges: .025, .030, .034, .035, .040, .045	.013-.015" ±.00043" .016-.019 ±.00047" .020-.024" ±.00055"	1/2 x 3-1/32"	
572B	22	.0015, .002, .0025, .003, .004, .005, .006, .007, .008, .009, .010, .012, .013, .014, .015, .016, .018, .020, .022, .025, .030, .035	.025-.031" ±.00067" .032" and over ±.00075"	1/2 x 3-1/32"	
<b>Inch Reading Thickness Gauges with Tapered Leaves</b>					
66T	26	.0015, .002, .0025, .003, .004, .005, .006, .007, .008, .009, .010, .011, .012, .013, .014, .015, .016, .017, .018, .019, .020, .021, .022, .023, .024, .025		1/2-1/4 x 3-1/32"	Tapered leaves with Locking Device
172AT	9	.0015, .002, .003, .004, .006, .008, .010, .012, .015		1/2-1/4 x 3-1/32"	
172CT	8	.002, .003, .004, .006, .008, .010, .012, .015"		1/2 x 1/4 x 6"	
<b>Millimetre Reading Thickness Gauges with Straight Leaves</b>					
66MA	20	.05, .10, .15, .20, .25, .30, .035, .040, .045, .50, .066, .060, .65, .070, .075, .080, .085, .090, .095, 1.0	03-.09mm ±.004mm .10-.15mm ±.005mm .16-.31mm ±.007mm .32-.50mm ±.011mm	12.7 x 77mm	Straight leaves with Locking Device
173MA	13	0.03, 0.04, 0.05, 0.06, 0.07, 0.08, 0.09, 0.10, 0.15, 0.20, 0.30, 0.40, 0.50	.51-.60mm ±.014mm .63-1.00mm ±.017mm over 1.00mm ±.019mm	12.7 x 77mm	Tapered leaves with Locking Device
467M	13	0.04, 0.05, 0.06, 0.07, 0.08, 0.10, 0.15, 0.20, 0.30, 1.0, 2.0, 3.0, 5.0		12.7 x 114mm	
<b>Millimetre Reading Thickness Gauges with Tapered Leaves</b>					
172MBT	9	0.04, 0.05, 0.06, 0.07, 0.08, 0.10, 0.15, 0.20, 0.30		12.7-7 x 114mm	
173MAT	13	0.03, 0.04, 0.05, 0.06, 0.07, 0.08, 0.09, 0.10, 0.15, 0.20, 0.30, 0.40, 0.50		12.7-7 x 77mm	Tapered leaves with Locking Device
173MCT	13	0.03, 0.04, 0.05, 0.06, 0.07, 0.08, 0.09, 0.10, 0.15, 0.20, 0.30, 0.40, 0.50		12.7-7 x 152mm	

# FIXED GAUGES

## SCREW PITCH GAUGES

Screw pitch gauges are amongst the most useful tools in any machinists' tool box, as they quickly determine pitch of various threads. Gauges consist of a substantial steel case with a number of folding leaves at both ends, each leaf having teeth corresponding to a definite pitch, marked on each leaf.

- Specification: Starrett factory standard
- V, Unified, American National 60° thread (2.1/4 – 84 TPI)
- Whitworth standard 55° thread (Cat 476)
- International Metric standard 60° thread (Cat 156M and 159M)

Cat No	Leaves	TPI Range	Thread per inch (TPI)	Accuracy	Description	
155	27	2-1/4–28	2-1/4, 2-3/8, 2-1/2, 2-5/8, 2-3/4, 2-7/8, 3, 3-1/4, 3-1/2, 4, 4-1/2, 5, 5-1/2, 6, 7, 8, 9, 10, 11, 12, 13, 14, 16, 18, 20, 24, 28		With Locking Device and 60° Centre Gauge	
484	28	3-1/2–36	3-1/2, 4, 4-1/2, 5, 5-1/2, 6, 7, 8, 9, 10, 11, 11-1/2, 12, 13, 14, 15, 16, 18, 20, 22, 24, 26, 27, 28, 30, 32, 34, 36		With Locking Device	
6	30	4–42	4, 4-1/2, 5, 5-1/2, 6, 7, 8, 9, 10, 11, 11-1/2, 12, 13, 14, 15, 16, 18, 20, 22, 24, 26, 27, 28, 30, 32, 34, 36, 38, 40, 42		With Locking Device and 11-1/2 and 27 Pipe Thread Pitches	
474	28	4–80	4, 4-1/2, 5, 6, 7, 8, 9, 10, 11, 11-1/2, 12, 13, 14, 16, 18, 20, 24, 27, 28, 32, 36, 40, 44, 48, 56, 64, 72, 80	±0.05mm / ±0.002" between any two teeth	With Locking Device and 11-1/2 and 27 Pipe Thread Pitches	
472	51	4–84	First Corner 17 Leaves: 4, 4-1/2, 5, 5-1/2, 6, 7, 8, 9, 10, 11, 11-1/2, 12, 13, 14, 15, 16, 18 Second Corner 17 Leaves: 20, 22, 24, 26, 27, 28, 30, 32, 34, 36, 38, 40, 42, 44, 46, 48, 50 Third Corner 17 Leaves: 52, 54, 56, 58, 60, 62, 64, 66, 68, 70, 72, 74, 76, 78, 80, 82, 84	60° (±1°) for 20 pitch and coarse	With Locking Device and 11-1/2 and 27 Pipe Thread Pitches	
473	30	6–60	6, 7, 8, 9, 10, 11, 11-1/2, 12, 13, 14, 15, 16, 18, 20, 22, 24, 26, 27, 28, 30, 32, 34, 36, 38, 40, 42, 48, 50, 56, 60	(±2°) for finer than 20 pitch	With Positive Stop and 11-1/2 and 27 Pipe Thread Pitches	
476	30	3-1/2–60	3-1/2, 4, 4-1/2, 5, 6, 7, 8, 9, 10, 11, 12, 13, 14, 16, 18, 19, 20, 22, 24, 25, 26, 28, 30, 32, 36, 40, 44, 48, 50, 60		With Positive Stop	
156M	28	0.25-2.50mm	0.25, 0.30, 0.35, 0.40, 0.45, 0.50, 0.55, 0.60, 0.65, 0.70, 0.75, 0.80, 0.85, 0.90, 1, 1.10, 1.20, 1.25, 1.30, 1.40, 1.50, 1.60, 1.70, 1.75, 1.80, 1.90, 2, 2.50		With Locking Device	
159M	28	0.5-11.5mm	0.5, 0.75, 1, 1.10, 1.25, 1.5, 1.75, 2, 2.5, 3, 3.5, 4, 4.5, 5, 5.5, 6, 6.5, 7, 7.5, 8, 8.5, 9, 9.5, 10, 10.5, 11, 11.5		With Locking Device and 60° Centre Gauge	



# FIXED GAUGES

## 666

### THICKNESS GAUGES OR 'FEELER' STOCK IN ROLLS

The 666 thickness gauge is supplied in a case, making it very useful for cutting off the required length for adjusting tappets, spark plugs, distributor points, checking bearing clearance and gear play, fitting pistons, rings and pins, gauging narrow slots, etc. Feeler stock is also useful for shimming in fixturing and die work.

- Specification: Starrett factory standard (available upon request)
- Made of finest tempered steel
- House in plastic rewindable dispenser rolls for 0.03mm to 0.35mm / 0.001" to 0.015"
- Cardboard packing for 0.40mm to 0.50mm and 0.0005", 0.016" to 0.025"



666M-10

Cat No	Thickness	Accuracy	Length
666M-3	0.03mm	±0.004mm	7.6m
666M-4	0.04mm	±0.004mm	7.6m
666M-5	0.05mm	±0.004mm	7.6m
666M-6	0.06mm	±0.004mm	7.6m
666M-8	0.08mm	±0.004mm	7.6m
666M-10	0.10mm	±0.005mm	7.6m
666M-15	0.15mm	±0.004mm	7.6m
666M-20	0.20mm	±0.006mm	7.6m
666M-25	0.25mm	±0.006mm	7.6m
666M-30	0.30mm	±0.006mm	7.6m
666M-35	0.35mm	±0.006mm	7.6m
666M-40	0.40mm	±0.0075mm	6.1m
666M-45	0.45mm	±0.006mm	6.1m
666M-50	0.50mm	±0.006mm	6.1m
666-1/2	0.0005"	±0.006mm	25'
666-1	0.001"	±0.0002"	25'
666-1.1/2	.0015"	±0.0002"	25'
666-2	.002"	±0.0002"	25'
666-2.1/2	.0025"	±0.0002"	25'
666-3	.003"	±0.0002"	25'
666-4	.004"	±0.0002"	25'
666-5	.005"	±0.0002"	25'
666-6	.006"	±0.0002"	25'
666-7	.007	±0.0002"	25'
666-8	.008"	±0.00025"	25'
666-9	.009"	±0.00025"	25'
666-10	.010"	±0.00025"	25'
666-11	.011"	±0.00025"	25'
666-12	.012"	±0.0003"	25'
666-13	.013"	±0.0003"	25'
666-14	0.014"	±0.0003"	25'
666-15	0.015"	±0.0003"	25'
666-16	0.016"	±0.00035"	20'
666-17	0.017"	±0.00035"	20'
666-18	.018"	±0.00035"	20'
666-19	.019"	±0.00035"	20'
666-20	.020"	±0.0004"	20'
666-21	.021"	±0.0004"	20'
666-22	.022"	±0.0004"	20'
666-23	.023"	±0.0004"	20'
666-24	0.024"	±0.0004"	20'
666-25	0.025"	±0.0004"	20'

## 667

### THICKNESS GAUGES OR "FEELER" STOCK

667 thickness gauges (or 'Feeler' stock) are widely used in automotive, aviation, diesel and farm equipment manufacture and service and also in jig, fixture, gauge and experimental work.

- Specification: Starrett factory standard
- Made of finest tempered steel
- Finished in 300mm / 12" lengths, 12.7mm / 1/2" width
- Rounded ends make stock easier to work with
- 5mm (3/16") hole punched in the end for hanging

Cat No	Thickness	Accuracy	Cat No	Thickness	Accuracy
667M-3	0.03mm	±0.004mm	667-8	.008"	±0.00025"
667M-4	0.04mm	±0.004mm	667-9	.009"	±0.00025"
667M-5	0.05mm	±0.004mm	667-10	.010"	±0.00025"
667M-6	0.06mm	±0.004mm	667-11	.011"	±0.00025"
667M-8	0.08mm	±0.004mm	667-12	.012"	±0.0003"
667M-10	0.10mm	±0.005mm	667-13	.013"	±0.0003"
667M-15	0.15mm	±0.004mm	667-14	.014"	±0.0003"
667M-20	0.20mm	±0.006mm	667-15	.015"	±0.0003"
667M-25	0.25mm	±0.006mm	667-16	.016"	±0.00035"
667M-30	0.30mm	±0.006mm	667-17	.017"	±0.00035"
667M-35	0.35mm	±0.006mm	667-18	.018"	±0.00035"
667M-40	0.40mm	±0.0075mm	667-19	.019"	±0.00035"
667M-45	0.45mm	±0.006mm	667-20	.020"	±0.0004"
667M-50	0.50mm	±0.006mm	667-21	.021"	±0.0004"
667-1/2	0.0005"	±0.006mm	667-22	.022"	±0.0004"
667-1	0.001"	±0.0002"	667-23	.023"	±0.0004"
667-1.1/2	0.0015"	±0.0002"	667-24	.024"	±0.0004"
667-2	.002"	±0.0002"	667-25	.025"	±0.0004"
667-2.1/2	.0025	±0.0002"	667-26	.026"	±0.00045"
667-3	.003"	±0.0002"	667-27	.027"	±0.00045"
667-4	.004"	±0.0002"	667-28	0.028"	±0.00045"
667-5	.005"	±0.0002"	667-29	0.029"	±0.00045"
667-6	.006"	±0.0002"	667-30	0.030"	±0.00045"
667-7	.007"	±0.0002"			

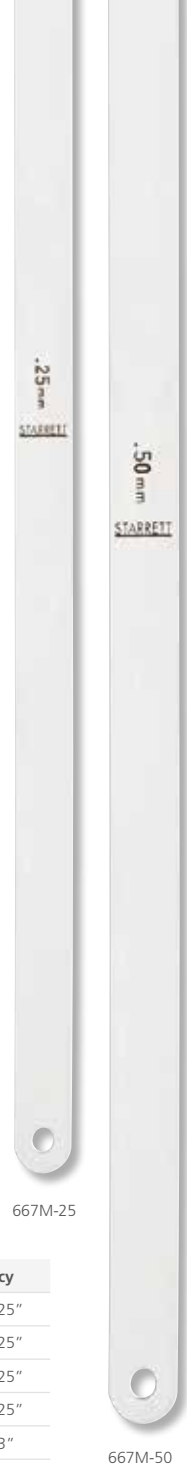

667M-25

667M-50

# PRECISION SHOP TOOLS

## 1620 TOOL AND INSTRUMENT OIL

A special high refining process makes Starrett tool and instrument oil colourless, and ensures thorough lubrication of close-fitting parts at extreme temperatures. It provides a strong, long lasting film over the entire area requiring protection.

- Maximum protection and lubrication of precision tools and light machinery
- Guards highly finished tools, parts and machine surface against rust
- Protects fishing tackle and other sporting equipment and keeps working parts in perfect condition

Cat No	Description	Packaging
1620	4 fl. Oz. (0.1 litre) Plastic bottle	Box of 12 x 0.1 litre



1620

## 1610 KLENSCRIBE LAYOUT DYE



1610-4

The opaque blue background 1610 Kleenscribe layout dye makes scribed lines stand out sharp and clear on clean, dry metal surfaces. It will not rub off on hands or clothing or flake away, and is unaffected by cutting lubricants and heat generated during machining.

Cat No	Description	Packaging
1610-4	4 oz (0.1 litre) Plastic bottle	Box of 12 x 0.1 litre

## 827 EDGE FINDERS

The work surface may be located easily, quickly and accurately with 827 Edge Finders. Work with flat, straight edges, shoulder, grooves, round work, studs, dowels, or centre points and scribed lines – all can be accurately located with this handy tool. Body and contacts are made of tool steel, hardened, ground and lapped to closed tolerances for diameter and concentricity.

### HOW TO USE

Edge finders are easy to use. They are placed in a collet or chuck. The worktable is then traversed to obtain contact between the rotating edge finder and the work. Contact will shift to a concentric position relative to the body and with very slight additional table adjustment, will move off centre with a decided wobble. At this point, the centre of the finder is exactly one-half the diameter of the contact from the work edge, permitting accurate location for other machining operations relative to the edge.

For locating centre points and scribed lines, the pointed contact is used by putting a pencil or rule against the centre point and making it run concentrically. Then the point is brought down to the centre point or intersection of the scribed lines and the table is adjusted so that when the tool barely touches the work, the lineup with the point in question can be ascertained.

Cat No	Description	Body Dia	Contact Dia	Accuracy (Concentricity)
827MA	Single end edge finder	6mm	10mm	0.005mm
827MB	Double end edge finder	6mm and pointed contact	10mm	0.005mm
827A	Single end edge finder	0.2"	0.375"	0.0002"
827B	Double end edge finder	0.2" and pointed contact	0.5"	0.0002"



Above left: Locating the centre with 827MB  
Left: Locating the edge of a part with 827MA

# PRECISION SHOP TOOLS

## 18

### AUTOMATIC CENTRE PUNCHES WITH ADJUSTMENT STROKE

- Internal mechanism automatically strikes a blow when downward pressure is applied
- Adjustable knurled cap regulates the force of the blow
- The spring tension, which regulates the blow, is constant so marks made by the point are uniform in depth and size for each setting
- The point can be easily removed for regrinding or replacement

Cat No	Description	Length	Diameter
18AA	Punch	100mm / 4"	11mm / 7/16"
18A	Punch	125mm / 5"	14mm / 9/16"
18C	Punch, Heavy-duty	130mm / 5-1/4"	17mm / 11/16"
PT06689	Point only for 18AA		
PT06690	Point only for 18A		
PT22256	Point only for 18C		



Rugged automatic centre punch with adjustable stroke

18A



## 818

### AUTOMATIC CENTRE PUNCH

The 818 automatic centre punch is similar to the 18C, except that it is lightweight with a knurled aluminium handle.

- No hammer required! Just hold the punch in an upright position, press the handle down, and a built-in mechanism strikes a perfect centre mark every time
- The force of the blow can be adjusted by turning the knurled cap
- Easy one-hand precision centre punching on metal, plastics, wood and other machinable materials

Cat No	Description	Length	Diameter
818	Automatic punch	125mm / 5"	16mm / 5/8"
PT22256	Point only for 818		



Easy one-hand precision centre punching

818



## 819

### HINGE-LOCATING AUTOMATIC CENTRE PUNCH

The 819 hinge locating automatic centre punch combines all the features of the 818 with an exclusive self-centring locating sleeve that automatically centres starter holes for screws.

- Eliminates the risk of drilling off centre, causing screws to pull hinges or hardware off centre
- Punch can be adjusted for striking light or heavy impressions by turning the knurled cap
- Point is easily removed for replacement (PT22256)

Cat No	Description	Length	Diameter
819	Hinge-Locating Automatic Centre Punch	125mm / 5"	16mm / 5/8"
PT22256	Point only for 818		



Automatically locates and centres holes through hinges, latches, catches, etc.

819



## PRECISION SHOP TOOLS

### 117

#### CENTRE PUNCHES WITH ROUND SHANK

The 117 centre punches are well proportioned, hardened and properly tempered, manufactured with round knurled grips and accurate centred tips.

Cat No	Length	Contact Point Diameter
117AA	75mm / 3"	1.5mm / 1/16"
117A	100mm / 4"	2mm / 5/64"
117B	100mm / 4"	2.5mm / 3/32"
117C	100mm / 4"	3mm / 1/8"
117D	100mm / 4"	4mm / 5/32"
117E	125mm / 5"	6.5mm / 1/4"
S117PC	Set of 5, 117AA, A, B, C, D in plastic case	



### 565

#### DRIVE PIN PUNCHES

The 565 drive pin punch is similar to the 117, except that it has a standard body length and a wider range.

Cat No	Length	Contact Point Diameter
565A	100mm / 4"	1.5mm / 1/16"
565B	100mm / 4"	2.5mm / 3/32"
565C	100mm / 4"	3mm / 1/8"
565D	100mm / 4"	4mm / 5/32"
565E	100mm / 4"	5mm / 3/16"
565F	100mm / 4"	5.5mm / 7/32"
565G	100mm / 4"	6.5mm / 1/4"
565H	100mm / 4"	8mm / 5/16"
S565WB	Set of 565A,B,C,D,E,F,G,H in plastic box	
S565PC	Set of 565A,B,C,D,E,F,G,H in plastic case	



### 248

#### DRIVE PIN PUNCHES

The 248 drive pin punches combine all the features of the 117 with an extra long body length. Punches are designed to withstand hard use and it is an ideal punch for machine shop and motor service jobs.

Cat No	Length	Contact Point Diameter
248A	200mm / 8"	3mm / 1/8"
248B	200mm / 8"	5mm / 3/16"
248C	200mm / 8"	6.5mm / 1/4"
248D	200mm / 8"	8mm / 5/16"
248E	200mm / 8"	9.5mm / 3/8"
S248PC	Set of 248A, B, C, D, E in plastic case	
S248	Set of 248A, B, C, D, E in plain box	



# PRECISION SHOP TOOLS

## 98 MACHINISTS' LEVELS

The 98 machinists' level is the finest level available. It features an involute longitudinal groove between the bearing flats for accurate seating on ground work, better centring and greater capacity to handle larger rounds. Groove and bearing flats are machined together for maximum accuracy.

- Standard: Starrett factory specification (available upon request)
- Vials are adjustable to a positive setting and are housed in satin chrome finished brass tubes with a friction fit closing cover to prevent breakage
- The 150 through 450mm main level vials have graduations that are approx. 80-90 seconds or 0.42mm per metre / 0.005" per foot). There are five, six or seven lines on each side of the bubble, depending on the base length



End view showing involute groove

Cat No	Size	Description
98-4	100mm / 4"	Without cross test vial
98-6	150mm / 6"	With cross test vial
98-8	200mm / 8"	With cross test vial
98-12	300mm / 12"	With single plumb vial and cross test vial
98-18	450mm / 18"	With double plumb vial and cross test vial



98-6

## 3097 PRECISION LEVEL

- Standard: Starrett factory specification (available upon request)
- Ground and graduated main vial of 10 seconds accuracy

Cat No	Size	Description
3097	220mm / 8.66"	Precision level



3097

## 199 MASTER PRECISION LEVEL

The base of the 199 master precision level is made from the finest quality seasoned cast iron and is precision-machined on the reference surface. Special alloy iron is used to obtain freedom from thermal effects, with the non-conductive top plate and black wrinkle finish on non-machined surfaces.

- Standard: Starrett factory specification (available upon request)
- The main vials have seven graduations on each side of the bubble
- Auxiliary level vials show lateral position and assist in horizontal setting
- Vial sensitivity for main vial at 7.5-9.5 seconds sensitivity and cross test at 6-7 minutes.

Cat No	Size	Description
199Z	380mm / 15"	Precision level



199Z

# PRECISION SHOP TOOLS

## 435 & 9 COMBINATION SETS

Supplied with reversible lock bolts, scriber, spirit level in both square head and protractor head, direct reading double 180° protractor scale, and hardened steel, photo-engraved blade. Cast iron heads with black wrinkle finish.

- Standard: Starrett factory specification (available upon request)
- 435 series is supplied with square, centre and reversible cast iron protractor heads and blade
- 9 series is supplied with square, centre and non-reversible cast iron protractor head and blade



Cat No	Size	Graduation	Blade
435ME-300	300mm/ 11.3/4"	1/2mm and 32 <sup>nd</sup> one Side; mm and 64 <sup>th</sup> reverse side	Regular
435ME-600	600mm/ 23.1/2"	1/2mm and 32 <sup>nd</sup> one Side; mm and 64 <sup>th</sup> reverse side	Regular
9ME-300	300mm/ 11.3/4"	1/2mm and 32 <sup>nd</sup> one Side; mm and 64 <sup>th</sup> reverse side	Regular
9ME-600	600mm/ 23.1/2"	1/2mm and 32 <sup>nd</sup> one Side; mm and 64 <sup>th</sup> reverse side	Regular

## 3020 TOOLMAKERS' GRADE STAINLESS STEEL SQUARES

The high quality 3020 toolmakers' grade stainless steel squares feature hardened, grounded and lapped stainless steel construction on both blade and beam. The beam is machined at the inner corner for clearance of burr or dirt.

- Standard: Starrett factory specification

Cat No	Size - Length	Length of Beam	Accuracy
3020-3	75mm/ 3"	50mm/ 2"	
3020-4	100mm/ 4"	75mm/ 3"	
3020-6	150mm/ 6"	100mm/ 4"	0.005mm/ 0.0002" for every 150mm/6"
3020-12	300mm/ 12"	175mm/ 7"	
S3020Z	Complete set of all 4 squares		



3020-3

## 154 ADJUSTABLE PARALLELS

The 154 adjustable parallels provide a wide range of uses in layout, gauging, inspection work and for set ups on various machine tools. Their adjustability makes it possible to adjust them to an exact size by micrometer measurement, and also permits use in place of several solid type parallels.

- Standard: Starrett factory specification
- Parallels slide smoothly and can be easily adjusted
- Smaller sizes A,B & C are locked by one screw and larger sizes D, E & F have 2 lock screws
- All parallels have a thickness of 7mm / 9/32"

Cat No	Range	Length	Accuracy (Parallelism of Length & Width)
154A	9.5-12.7mm / 3/8-1/2"	45mm / 1.3/4"	0.013mm / 0.0005"
154B	12.7-17.5mm / 1/2-11/16"	55mm / 2-1/8"	0.013mm / 0.0005"
154C	17.5-24mm / 11/16-15/16"	70mm / 2-11/16"	0.018mm / 0.0007"
154D	24-33mm / 15/16-1-5/16"	90mm / 3-9/16"	0.018mm / 0.0007"
154E	33-44mm / 1-5/16-1-3/4"	105mm / 4-3/16"	0.023mm / 0.0009"
154F	44-57mm / 1.3/4-2.1/4"	130mm / 5-1/16"	0.023mm / 0.0009"
S154SZ	Set of 154A,B,C,D in case		
S154LL	St of 154A,B,C,D,E,F in case		



S154LZ



# GAUGE BLOCK SETS

## GAUGE BLOCKS – MAJOR PRODUCT CHARACTERISTICS

Precision gauge blocks are the primary standards vital to dimensional quality control in the manufacture of parts. The four major characteristics that are necessary for a precision gauge block are accuracy, surface finish, wear resistance and dimensional stability. Other factors are corrosion resistance, hardness, thermal conductivity and coefficient of expansion.

### ACCURACY

All Starrett-Webber gauge blocks meet or exceed all known specifications. The flatness, parallelism and surface finish necessary to achieve the required accuracies are the same as or better than government requirements.

### STABILITY

Starrett-Webber gauge blocks do not change in size except through normal wear. Gauge block stability is a characteristic that our Webber Gauge Division has mastered with over eighty years of experience. Our gauge blocks withstand the test of time.

### HARDNESS

Steel blocks have a Rockwell "C" hardness of approximately 64-65. Chromium Carbide blocks have a Rockwell "C" hardness of 71-73, with an unusually fine, hard grain structure, giving them exceptional resistance to wear and abrasion.

### THERMAL CONDUCTIVITY AND COEFFICIENT OF EXPANSION

These are not important considerations when measurements are taken in temperature-controlled environments. This is primarily done when measuring to micro inches or microns.

## MICROACCURATE B-GRADE RECTANGULAR STEEL GAUGE BLOCK SETS

Ideal for general shop floor use, these B-Grade gauge block sets are very affordable.

- Etched, unique serial numbers are included on each block. Custom numbers are not available
- Sets available with a choice of two types of calibration certificate, as described below
- Metric system sets have a tolerance of  $\pm 1.25\mu\text{m}$
- Inch system sets have a tolerance of  $\pm 50\mu\text{in}$



RS 81.B

Cat No	Block Per Set	Blocks Included in Set	Steps
RS88.MB	88	1 block .5mm 1 block 1.0005mm 9 blocks 1.001 Through 1.009mm	- - 0.001mm
RS88.MW	88	49 blocks 1.01 Through 1.49mm 18 blocks 1 Through 9.5mm 10 blocks 10 Through 100mm	0.1mm 0.5mm 10mm
RS112.MB	112	1 block .5mm 1 block 1.0005mm 9 blocks 1.001 Through 1.009mm	- - 0.001mm
RS112.MW	112	49 blocks 1.01 Through 1.49mm 48 blocks 1 Through 24.5mm 4 blocks 25 Through 100mm	0.01mm 0.5mm 25mm
RS81.B	81	9 Blocks .1001 Through .1009" 49 Blocks .101 Through .149" 19 Blocks .050 Through .950"	0.0001" 0.001" 0.050"
RS81.W	81	4 Blocks 1.000 Through 4.000"	1.0"

Specification	
RS88.MB	Calibration performed at Webber Gauge in Cleveland, OH. Certificate of Calibration with NVLAP® accreditation. Calibration in accordance with ISO 17025 with dated calibration certificate and NIST traceability number. The name and address of the user may be added to the calibration certificate.
RS112.MB	<b>Inch System (RS 81.B)</b> uncertainty of measurement (k=2): $U = 6 + L$ where L is in inches, but U not less than 7 min.
RS81.B	<b>Metric Systems (RS 88.MB &amp; RS 112.MB)</b> uncertainty of measurement (k=2): $U = 0.15 + .001L$ where L is in millimetres, but U not less than 0.18 $\mu\text{m}$ .
RS88.MW	Calibration performed in China in partnership with Webber Gauge. Webber Gauge samples the measurements to monitor the calibration results. Calibrations are traceable to NIST, but no NIST traceability number or dates will be given. The name and address of the user will be left blank on the calibration certificate.
RS112.MW	<b>Inch System (RS 81.W)</b> uncertainty of measurement (k=2): 10 $\mu\text{in}$ .
RS81.W	<b>Metric Systems (RS 88.MW &amp; RS 112.MW)</b> uncertainty of measurement (k=2): $U = 0.25 \mu\text{m}$ .

# GAUGE BLOCK SETS

## RECTANGULAR STEEL – METRIC SYSTEM

- All sets include etched serial numbers and NIST calibration certificate
- Block with 1mm base

Cat No	Block Per Set	Blocks Included in Set	Steps
RS9.MA1	9	3 blocks 1.0, 2.0, 2.25mm 4 blocks 2.5, 3.0, 5.0, 10.0mm 2 blocks 15.0, 25.0mm	- - -
RS45.MA1	45	9 blocks 1.001 Through 1.00mm 9 blocks 1.01 Through 1.09 mm 9 blocks 1.1 Through 1.9mm 9 blocks 1 Through 9mm 9 blocks 10 Through 90mm	0.001mm 0.01mm 0.1mm 1.0mm 10.0mm
RS88.MA1	88	1 block .5mm 1 block 1.0005mm 9 blocks 1.001 Through 1.009mm 49 blocks 1.01 Through 1.49mm 18 blocks 1 Through 9.5mm 10 blocks 10 Through 100mm	- - 0.001mm 0.01mm 0.5mm 10.0mm
RS112.MA1	112	1 block .5mm 1 block 1.0005mm 9 blocks 1.001 Through 1.009mm 49 blocks 1.01 Through 1.49mm 48 blocks 1 Through 24.5mm 4 blocks 25 Through 100mm	- - 0.001mm 0.01mm 0.5mm 25mm
RS10.MA	10	10 blocks 2.5, 5.1, 7.7, 10.3, 12.9, 15.0, 17.6, 20.2, 22.8, 25.0mm	Micrometer Checking Set (accuracy grade AS1 )



## RECTANGULAR STEEL – INCH SYSTEM

- All set includes etched serial numbers and NIST calibration certificate

Cat No	Block Per Set	Blocks Included in Set	Steps
RS81.A1	81	9 Blocks .1001 Through .1009" 49 Blocks .101 Through .149" 19 Blocks .050 Through .950" 4 Blocks 1.000 Through 4.000"	0.0001" 0.001" 0.010" 1.00"
RS88.A1	88	As RS 81.A1 Set, plus 3 Blocks .100025, .10005, .100075" 4 Blocks 1/16, 5/64, 3/32, 7/64"	
RS34.A1	34	9 Blocks .1001 Through .1009" 9 Blocks .101 Through .109" 9 Blocks .110 Through .190" 4 Blocks .100, .200, .300, .500" 3 Blocks 1.000, 2.000, 4.000"	0.0001" 0.001" 0.010" - -
RS28A1	28	1 Block .02005" 9 Blocks .0201 Through .0209" 9 Blocks .021 Through .029" 9 Blocks .010 Through .090"	- 0.0001" 0.001" 0.010"
RS9.A1	9	1 Block .0625, .100, .125, .200, .250, .300, .500, 1.000, 2.000"	-
RS10.A	10	10 blocks .105, .210, .315, .420, .500, .605, .710, .815, .920, 1.000"	Micrometer Checking Set (accuracy grade AS1)



# GAUGE BLOCK SETS

## GAUGE BLOCK TOLERANCE

	Grade AA B89.1.9 Grade 00			Grade A1 B89.1.9 Grade 0			B89.1.9 Grade AS1		
	Size Tolerance	Variation in Length Tolerance	Flatness Tolerance	Size Tolerance	Variation in Length Tolerance	Flatness Tolerance	Size Tolerance	Variation in Length Tolerance	Flatness Tolerance
Thru 0.5mm	+ .10/- .10	.05	.05	+ .14/- .14	.10	.10	+ .30/- .30	.16	.15
Thru 10mm	+ .07/- .07	.05	.05	+ .12/- .12	.10	.10	+ .20/- .20	.16	.15
Thru 25mm	+ .07/- .07	.05	.05	+ .14/- .14	.10	.10	+ .30/- .30	.16	.15
Thru 50mm	+ .10/- .10	.06	.05	+ .20/- .20	.10	.10	+ .40/- .40	.18	.15
Thru 75mm	+ .12/- .12	.07	Rect (.05), Sq. (.07)	+ .25/- .25	.12	.10	+ .50/- .50	.18	.15
Thru 100mm	+ .15/- .15	.07	Rect (.05), Sq. (.07)	+ .30/- .30	.12	.10	+ .60/- .60	.20	.15
Thru 125mm	+ .20/- .20	.08	Rect (.05), Sq. (.07)	+ .40/- .40	.14	.10	+ .80/- .80	.20	.15
Thru 150mm	+ .20/- .20	.08	Rect (.05), Sq. (.07)	+ .40/- .40	.14	.10	+ .80/- .80	.20	.15
Thru 175mm	+ .25/- .25	.09	.10	+ .50/- .50	.16	.15	+ 1.0/- 1.0	.25	.18
Thru 200mm	+ .25/- .25	.09	.10	+ .50/- .50	.16	.15	+ 1.0/- 1.0	.25	.18
Thru 250mm	+ .30/- .30	.10	.10	+ .60/- .60	.16	.15	+ 1.2/- 1.2	.25	.18
Thru 300mm	+ .35/- .35	.10	.10	+ .70/- .70	.18	.15	+ 1.4/- 1.4	.25	.18
Thru 400mm	+ .45/- .45	.12	.10	+ .90/- .90	.20	.15	+ 1.8/- 1.8	.30	.18
Thru 500mm	+ .50/- .50	.14	.10	+ 1.1/- 1.1	.25	.15	+ 2.2/- 2.2	.35	.18



	Grade AA B89.1.9 Grade 00			Grade A1 B89.1.9 Grade 0			B89.1.9 Grade AS1		
	Size Tolerance	Variation in Length Tolerance	Flatness Tolerance	Size Tolerance	Variation in Length Tolerance	Flatness Tolerance	Size Tolerance	Variation in Length Tolerance	Flatness Tolerance
Thru .050"	+4/-4	2	2	+6/-6	4	4	+12/-12	6	6
Thru .400"	+3/-3	2	2	+5/-5	4	4	+8/-8	6	6
Thru 1"	+3/-3	2	2	+6/-6	4	4	+12/-12	6	6
Thru 2"	+4/-4	2	2	+8/-8	4	4	+16/-16	6	6
Thru 3"	+5/-5	3	Rect.: 2, Sq.: 3	+10/-10	4	4	+20/-20	6	6
Thru 4"	+6/-6	3	Rect.: 2, Sq.: 3	+12/-12	5	4	+24/-24	8	6
Thru 5"	+8/-8	3	Rect.: 2, Sq.: 3	+16/-16	5	4	+32/-32	8	6
Thru 6"	+8/-8	3	Rect.: 2, Sq.: 3	+16/-16	5	4	+32/-32	8	6
Thru 7"	+10/-10	4	4	+20/-20	6	6	+40/-40	10	7
Thru 8"	+10/-10	4	4	+20/-20	6	6	+40/-40	10	7
Thru 10"	+12/-12	4	4	+24/-24	6	6	+48/-48	10	7
Thru 12"	+14/-14	4	4	+28/-28	7	6	+56/-56	10	7
Thru 16"	+18/-18	5	4	+36/-36	8	6	+72/-72	12	7
Thru 28"	+20/-20	6	4	+44/-44	10	6	+88/-88	14	7

# METROLOGY

## 698 AND 699 VIDEO BORESCOPIES

- The 698 and 699 video borescopes are ideal for inspection of inaccessible areas
- Flexible, water resistant conduit with high quality metal tip
- The camera has IP67 levels of protection and the body has IP65 levels of protection against coolants, water, chips, dust and dirt often found in machine shop environments



699-5.5

Cat No	Description	Probe
699-5.5	Video borescope, manual, video output cable, USB cable, 45° mirror, 2GB Micro SD card, case	5.5mm
699-10	Video borescope, manual, video output cable, USB cable, 2GB Micro SD card, case	10mm
698-10	Video borescope, manual, video output cable, case	10mm
PT99559	45° mirror for 699-5.5 video borescope	
CP10-1M	Camera probe, 10mm Dia. x 1m long	
CP10-3M	Camera probe, 10mm Dia. x 3m long	
CP5.5-1M	Camera probe, 5.5mm Dia. x 1m long	

Model Specifications		699-5.5	699-10	698-10
Camera Probe	Diameter	5.5mm / 0.217"	10mm / 0.394"	10mm / 0.394"
	Focal Distance	20 - 70mm / 0.79 - 2.76"	30 - 60mm / 1.18 - 2.36"	30 - 60mm / 1.18 - 2.36"
	fov	60° Diagonal	60° Diagonal	60° Diagonal
	Resolution	720 x 480 (D1)	640 x 480 (VGA)	640 x 480 (VGA)
	Light Source	White LCD x4	White LCD x6	White LCD x6
	Material	Stainless Steel	Stainless Steel	Stainless Steel
	IP Protection	Camera IP67 Body IP65	Camera IP67 Body IP65	Camera IP67 Body IP65
Conduit	Length, Type	1m / 39.4" Flexible	1m / 39.4" Gooseneck	1m / 39.4" Gooseneck
Temperature	Operating	0 - 50°C / 32° - 122°F	0 - 50°C / 32° - 122°F	0 - 50°C / 32° - 122°F
	Storage	-10 - 60°C / 14° - 140°F	-10 - 60°C / 14° - 140°F	-10 - 60°C / 14° - 140°F
Display	Size	89mm / 3.5" TFT	89mm / 3.5" TFT	61mm / 2.4"
	Photo Res.	720 x 480 (D1) & 360 x 240 (CIF) Jpeg Format		N/A
	Video Res.	720 x 480 (D1) & 30fps@360 x 240 (CIF) Motion Jpeg, Vdec Recording 30fps AVI Playback		480(W) x 230(H)
Video Output		NTSC / PAL	NTSC / PAL	NTSC / PAL
Memory		Micro SD Card Slot	Micro SD Card Slot	N/A
Data Output		USB 2.0	USB 2.0	N/A
Power Source	Power	4 x AA Batteries, 5V DC & 12V DC		4 x AA Batteries, 5V DC
	Charge Duration	3 hours	3 hours	4 hours
Size & Weight	Weight	450gms / 1lb (excluding batteries)		
	Dimensions	L: 225mm (8.86"), W: 102mm (4.02"), H: 66mm (2.60")		
Accessories Included		Owners Manual, Video Output Cable, USB Cable, 2GB Micro SD Card, Case		Owner Manual, Video Output Cable, Case



## 3814 & 3814E BENCH HARDNESS TESTERS

The 3814 Hardness Tester provides reliable Rockwell Hardness values on all types of metal and alloys, hard or soft, and in many shapes. This reliable bench hardness tester has a high quality casting, is ergonomically designed for easy operation and is engineered to ensure accurate results. It is an ideal basic hardness solution, economically priced to suit a variety of lab, workshop, toolroom and inspection department applications. The bench hardness tester conforms to ASTM E-18 standard. The tester is furnished with a diamond indenter, a 1.6mm / 1/16" ball indenter, three certified test blocks, four test tables – 149mm / 5.87" and 63.5mm / 2.5" flat anvils, 15.9mm / 5/8" spot anvil and a standard vee anvil – and an accessory case.

Cat No	Description
3814	Analogue Bench Standard Rockwell Hardness Tester
3814E	Digital Bench Standard Rockwell Hardness Tester
Standard Accessories supplied with 3814 and 3814E	"C" regular Diamond Indenter 1/16" Ball Indenter (Plus 5 Spare Balls) Hardness Test Blocks 2 HRC / 1 HRB 3 Test Table Anvils 150mm Dia, 60mm Dia, Standard Vee Anvil 40mm Dia Installation & User manual
3815E	Digital Bench combined Standard & Superficial Hardness Tester
Standard Accessories completed with 3815E	"C" regular Diamond Indenter 1/16" Ball Indenter (Plus 5 Spare Balls) Hardness Test Blocks 2 HRC / 1 HRB / 2 HRN / 1 HRT 3 Test Table Anvils 150mm Dia, 60mm Dia, Standard Vee Anvil 40mm Dia Installation & User manual

3814E Digital Bench Standard Rockwell Hardness Tester Technical Specification (Standard Rockwell)	
Standard Rockwell Scales	a, b, c, d, e, f, g, h, k, l, m, p, r, s
Major Load	60 Kgf, 100 Kgf, 150 Kgf
Minor Load	10 Kgf Preload
Display	Digital Multifunction Readout Display
Test Force Application	Dead Weight System
Test Force Control	Hydraulic
Conversion Scales	Brinell, Vickers & All Rockwell Scales
Cylindrical Compensation Correction	√
Data Output for Computer / Printer	USB
Memory for 99 Readings	√
50 Test Program Settings & Full Statistics	√
Tolerance Limit Settings	√
Hardness Resolution	0.01 of a Rockwell Unit
Maximum Specimen Height / Size	(Vertical) 170mm (Horizontal) 165mm (from Centre Line)
Minimum Specimen Height / Size	External Surfaces & Cylindrical Surfaces down to 3mm Dia
Accuracy Specification	ASTM E-18
Machine Dimensions H/W/D	750 x 150 x 500 mm
Net Weight / Gross Weight	86 Kg / 110 Kg
Power Supply	110V/220V - 50/60Hz

Digital readout for 3814E / 3815E  
Bench Hardness Tester



3814E



Analogue readout for 3814 Bench  
Hardness Tester

3815E Digital Bench Combined Standard & Superficial Hardness Tester Technical Specification (Combined Standard & Superficial Rockwell)		
Combined	Standard Rockwell	Superficial Rockwell
Rockwell Scales	a, b, c, d, e, f, g, h, k, l, m, p, r, s	N, T, W, X, Y
Major Load	60 Kgf, 100 Kgf, 150 Kgf	15 Kgf, 30 Kgf, 45 Kgf
Minor Load	10 Kgf Preload	3 Kgf Preload
Display	Digital Multifunction Readout Display	
Test Force Application	Dead Weight System	
Test Force Control	Hydraulic	
Conversion Scales	Brinell, Vickers & All Rockwell Scales	
Cylindrical Compensation Correction	√	
Data Output for Computer / Printer	USB	
Memory for 99 Readings	√	
50 Test Program Settings & Full Statistics	√	
Tolerance Limit Settings	√	
Hardness Resolution	0.01 of a Rockwell Unit	
Maximum Specimen Height / Size	(Vertical) 170mm (Horizontal) 165mm (from Centre Line)	
Minimum Specimen Height / Size	External Surfaces & Cylindrical Surfaces down to 3mm Dia	
Accuracy Specification	ASTM E-18	
Machine Dimensions H/W/D	750 x 150 x 500 mm	
Net Weight / Gross Weight	76 Kg / 96 Kg	
Power Supply	110V/220V - 50/60Hz	

# METROLOGY

## TEST BLOCKS AND ACCESSORIES FOR HARDNESS TESTERS

Starrett blocks can be used to test Rockwell, Brinell or Vickers scales. They are available in steel, brass and aluminium. Each block is serialised, with a certificate detailing the environmental conditions used to test the block.

Actual readings are given, with the averages of these readings: min. reading, max reading and a repeatability figure. The blocks are calibrated according to ASTM E-18 standards, ANSI (NCSL) Z540-1, (ISO) 10012-1, ISO/IEC 17025 and Mil-std 45662A.

Starrett hardness test blocks are manufactured from square steel or brass plates, as opposed to the more common round bar stock. The use of the plate gives a more accurate and consistent surface for inspection. Metallurgical tests have proven that during the production of round bar stock, suspended carbides in the mix migrate to the centre of the rod. The scientific name for this condition is carbide segregation and results in different readings being found in the centre of a rod rather than at its outer edges. Some manufacturers remedy this situation by removing the centres from their blocks.

Hardness test blocks are designed to be used only on one side and the indents should be more than 0.25mm / .010" from the centres of two indents or no closer to the block's edge than 1.01mm / .040".

Calibration kits are also available from Starrett. No facility with a hardness tester in use should be without a calibration kit. These kits come with from 3 to 20 calibrated test blocks and the serialised penetrator that was used to inspect each of the blocks in the set. When a discrepancy is detected in a tester, these kits allow you to determine the direction to proceed to resolve the issue.

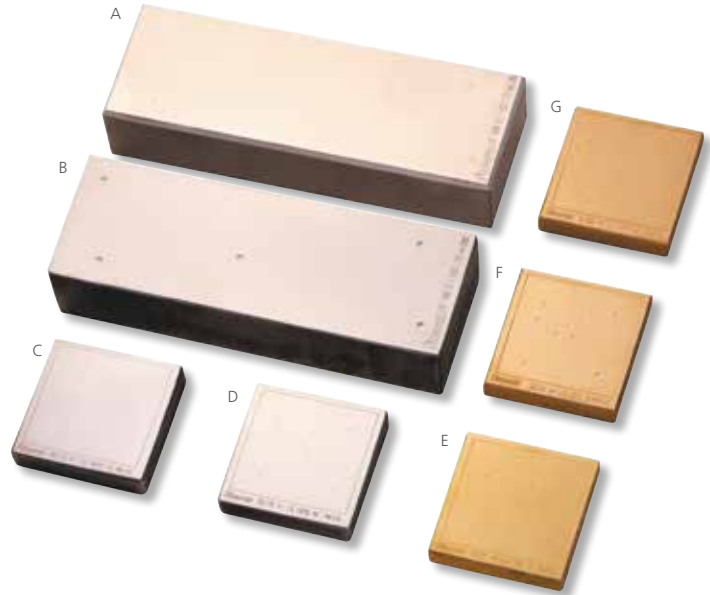

Rockwell and Brinell test blocks at a variety of hardness levels. (A) Aluminum Brinell, (B) Steel Brinell, (C) Vickers, (D) Rockwell, (E) 187.5kg/2.5mm Brinell, (F) Extra-Soft Rockwell and (G) Brass Rockwell.

ROCKWELL TEST BLOCKS	
Description †	Part No.
RC63 Test Block	PT05050
RC60 Test Block	PT05051
RC55 Test Block	PT05052
RC50 Test Block	PT05053
RC45 Test Block	PT05054
RC40 Test Block	PT05055
RC35 Test Block	PT05056
RC30 Test Block	PT05057
RC25 Test Block	PT05058
RB90 Test Block	PT05059
RB80 Test Block	PT05060
RB70 Test Block	PT05061
RB60 Test Block	PT05062
RB50 Test Block	PT05063
RB40 Test Block	PT05064
RB30 Test Block	PT05065
RB20 Test Block	PT05067
RB10 Test Block	PT05068
RA80 Test Block	PT05069
RA70 Test Block	PT05091
RA60 Test Block	PT05092
RF100 Test Block	PT05100

ROCKWELL TEST BLOCKS	
Description †	Part No.
RF90 Test Block	PT05101
RF80 Test Block	PT05102
RF70 Test Block	PT05103
RF60 Test Block	PT05104
RF50 Test Block	PT05105
RE100 Test Block	PT05106
RE90 Test Block	PT05107
RE80 Test Block	PT05108
RE70 Test Block	PT05112
RE60 Test Block	PT05113
RE50 Test Block	PT05114
HR30N80 Test Block	PT05115
HG30N70 Test Block	PT05122
HR30N60 Test Block	PT05123
HR30N50 Test Block	PT05124
HR30N40 Test Block	PT05125
HR30T80 Test Block	PT05127
HR30T70 Test Block	PT05128
HR30T60 Test Block	PT05129
HR30T50 Test Block	PT05130
HR30T40 Test Block	PT05177
HR30T30 Test Block	PT05178

ROCKWELL TEST BLOCKS	
Description †	Part No.
HR30T20 Test Block	PT05179
HR30T10 Test Block	PT05180
HR15N90 Test Block	PT05181
HR15N80 Test Block	PT05182
HR15N70 Test Block	PT05183
HR15T90 Test Block	PT05184
HR15T80 Test Block	PT05185
HR15T70 Test Block	PT05186
HR15T60 Test Block	PT05187
HR45T70 Test Block	PT05188
HR45T60 Test Block	PT05189
HR45T50 Test Block	PT05191
HR45T40 Test Block	PT05192
HR45T20 Test Block	PT05193
HR45T10 Test Block	PT05194
HRH90 Test Block	PT05195
HRH80 Test Block	PT05196
HRR120 Test Block	PT05197
HR30Y Test Block	PT05198
HRM Test Block	PT05199
HR15W Test Block	PT05200

† Values expressed are not exact but will range within acceptable limits

# METROLOGY

## TEST BLOCKS AND ACCESSORIES FOR HARDNESS TESTERS

BRINELL TEST BLOCKS	
Description	Part No.
3000kg High Brinell Test Block	PT05257
3000kg Low Brinell Test Block	PT05258
500kg High Brinell Test Block	PT05259
500kg Low Brinell Test Block	PT05260



ANVILS AND TABLE		
Letter	Description	Part No.
A	Pedestal Anvil	PT05267
B	2-1/2" Flat Anvil	PT05268
C	Small "V" Anvil	PT05269
D	Large "V" Anvil	PT05270
E	8" Anvil Testing Table	PT05271



Penetrators  
Contact Starrett for more information



MASTER CALIBRATION KITS	
Description	Part No.
HRC 3-Block Master Calibration Kit	PT05272
HR30N 3-Block Master Calibration Kit	PT05273
HRB 3-Block Master Calibration Kit	PT05276
C&B Scale 20-Block Master Calibration Kit	PT05277
C&30N Scale 6-Block Master Calibration Kit	PT05278

PENETRATORS		
Letter	Description	Part No.
E	"C" Regular, No Thread	PT05245
E	Indetron with Internal Thread	PT05246
G	Versitron/New Age with External Thread	PT05247
E	"N" Regular, No Thread	PT05248
D	1/16" (1.6mm) Ball with Holder	PT05249
C	1/8" (1.7mm) Ball Complete with Holder	PT05250
B	1/4" (6.4mm) Ball Complete with Holder	PT05251
A	1/2" (12.7mm) Ball Complete with Holder	PT05252
	1/16" (1.6mm) Carbide Ball Only, with Certification	PT05253
	1/8" (1.7mm) Carbide Ball, with Certification	PT05254
	1/4" (6.4mm) Carbide Ball, with Certification	PT05255
	1/2" (12.7mm) Carbide Ball, with Certification	PT05256
	Heavy Load, Vickers 5kg Load	PT05261
	Heavy Load Indentor Vickers	PT05264
	Min. Brinell 2 1/2mm Ball	PT05265
	Min. Brinell Block 187 1/2kg, 2-1/2mm Ball	PT05266

# METROLOGY

## 3810A AND 3811A PORTABLE HARDNESS TESTERS

The 3810A and 3811A portable hardness testers combine fast test speeds with ample memory and output. They perform tests that easily convert to most popular hardness scales such as Rockwell, Brinell, Vickers and Shore.

The tester is easy to use. Simply load the impact body, place the impact body on your test piece, then push the button to begin testing.

The testers are designed to test large hard parts that cannot be brought to a bench top machine. For example, tool steel should be close to 25mm / 1" of solid material. The testers come with a D impact device, calibration block, cleaning brush, manual and a carrying case.

The 3810A is supplied with a built in printer.

- Accuracy:  $\pm 0.5\%$  (referred to L=800)
- Memory capacity (100 groups)

Cat No	Description
3810A	Tester, D impact device, calibration block, cleaning brush, operation manual, custom carry case
3811A	Digital portable hardness tester with impact device D, calibrated test block, cleaning brush and carry case
HT1800-110	D+15 impact device. Very narrow contact area with set backed measurement coil. Measures hardness in grooves and recesses.
HT1800-115	DL impact device. Needle front section with 4mm diameter and 50mm length. For testing in confined spaces such as groove bases and special components such as gear wheels.
HT1800-125	G impact device. For components such as heavy castings and forgings. Enlarged test tip and increased impact energy range. For lower quality finishes measuring in the Brinell range only. G block required.
HT1800-130	C impact device. Reduced impact energy probe for measuring hardness of coatings and surface hardened, thin wall or impact-sensitive components. Applies superficial indentation.
HT1800-120	DC impact device. Very short for confined areas such as internal bores for various inside measurements.
HT1800-100	Replacement D impact device. Universal standard probe for a wide variety of applications.
HT1800-102	Replacement cable for all impact devices
HT1800-105	Replacement impact body D
HT1300-01	Leeb D test block
HT1100G-01	Leeb G test block
SR38R	Support ring set

Style	Application
D+15	Very narrow contact area with a set backed measurement coil. Measures hardness in grooves and recesses. Weight: 80g
DC	Extremely short impact device. Used for very confined spaces such as, holes, cylinders and internal measurements
C	Reduced impact energy probe (2 ft-lb) for measuring hardness of coatings, surface hardened, thin wall or impact sensitive components. Applies superficial indentation. Weight: 75g
G	Enlarged test tip and increased impact energy range (72 ft-lb – approx. 9 times the D). For lower quality finishes measuring in the Brinell range only (max. 650 HB). Designed for components like heavy castings, forgings. Weight: 250g
DL	Needle front section with 4mm diameter and 50mm length. Ideal for testing in confined spaces, the base of grooves and special components like gear wheels. Steel/Cast steel



3811A

Includes base instrument, impact device D, calibrated test block, custom carry case, cleaning brush and operation manual

Optional Remote Impact Devices



3810A

# METROLOGY

## 3810A AND 3811A PORTABLE HARDNESS TESTERS



3810A

METROLOGY

### TECHNICAL DATA FOR STARRETT HARDNESS IMPACT DEVICES

Technical Data for Impact Devices		D/DC/DL	D+15	C	G
Impact Energy		11 Nmm	11 Nmm	3 Nmm	90 Nmm
Mass of the Impact Body		5.5g	7.8g	3.0g	20g
Test Tip DL: 7.3 g	Hardness	1600 HV	1600 HV	1600 HV	1600 HV
	Diameter	3mm	3mm	3mm	5mm
	Material	Tungsten carbide	Tungsten carbide	Tungsten carbide	Tungsten carbide
Impact Device	Diameter	20mm	20mm	20mm	30mm
	Length	147/86mm	162mm	141mm	254mm
	Weight	75/50 g	80 g	75 g	250 g
Max. Hardness of Sample		940 HV	940 HV	1000 HV	650 HB
Preparation of Surface	Roughness class ISO	N7	N7	N5	N9
	Max. roughness depth Rt	10µm	10µm	2.5µm	30µm
	Average roughness Ra	2µm	2µm	0.4µm	7µm
Min. Weight of Sample	Of compact shape	5kg	5kg	1.5kg	15kg
	On solid support	2kg	2kg	0.5kg	5kg
	Coupled on plate	0.1kg	0.1kg	0.02kg	0.5kg
Min. Thickness of Sample	Coupled	3mm	3mm	1mm	10mm
	Min. thickness of layers	0.8mm	0.8mm	0.2mm	-
Indentation of Test Tip with 300 HV	Diameter	0.54mm	0.54mm	0.38mm	1.03mm
	Depth	24µm	24µm	12µm	53µm
Indentation of Test Tip with 600 HV	Diameter	0.45mm	0.45mm	0.32mm	0.90mm
	Depth	17µm	17µm	8µm	41µmC
Indentation of Test Tip with 800 HV	Diameter	0.35mm	0.35mm	0.30mm	-
	Depth	10µm	10µm	7µm	-

### APPLICATION AND HARDNESS RANGES FOR STARRETT HARDNESS IMPACT DEVICES

Optional Impact Devices					
Material	HRC	HRB	HB	HV	HSD
<b>Impact Device – D, DC Measuring Range 200-900†</b>					
Steel	20.0-67.9	59.6-99.5	80-647	80-940	32.2-99.5
C.W. Tool Steel	20.4-67.1	-	-	80-898	-
Gray Cast Iron	-	-	93-334	-	-
Nodular Cast Iron	-	-	131-387	-	-
Cast Aluminium	-	-	30-159	-	-
Brass	-	13.5-95.3	40-173	-	-
Bronze	-	-	60-290	-	-
Copper	-	-	45-315	-	-
<b>Impact Device – D+15, Measuring Range 300-900† (not shown)</b>					
Steel and Cast Steel	19.3-67.9	-	80-638	80-937	33.3-99.3
<b>Impact Device – C, Measuring Range 350-950†</b>					
Steel and Cast Steel	20.0-69.5	-	80-683	80-996	31.9-99.6
<b>Impact Device – G, Measuring Range 300-750†</b>					
Steel and Cast Steel	-	47.7-99.9	90-646	-	-
Gray Cast Iron	-	-	92-326	-	-
Nodular Cast Iron	-	-	127-364	-	-
<b>Impact Device – DL, Measuring Range 300-900†</b>					
Steel and Cast Steel	20-68	37-100	80-650	80-940	30-97

† Leeb Measuring Range

# METROLOGY

## 3805B ELECTRONIC DUROMETER

The 3805B measures Shore A values for a wide variety of soft materials including: rubber: soft vulcanized (i.e. tire), natural nitrile; elastomeric materials (rubber and rubber-like): GR-S, GR-1, neoprene, thiokol, flexible polyacrylic esters; other softer materials including wax, felt, leather, etc. (materials that would normally yield under fingernail pressure).



3805B

Cat No	Range	Accuracy and repetitive deviation	Resolution	Deviation
3805B	0-100HSA	20-90HSA $\pm 1$ grade	0.5H	<1%H
SRB-3	3 Rubber test block certified Set (optional)			

## 3813 COATING THICKNESS GAUGE

The gauge uses an integrated probe to automatically determine whether the substrate is ferrous or non-ferrous. Then, it either detects the thickness of non-magnetic coating on a magnetic substrate (ferrous) or the insulating coating on a non-magnetic conductive substrate (non-ferrous).

- Max surface temperature of test object 150°C (max contact time 2 seconds)
- Power source – 4 x AA battery



3813

Cat No	Range	Resolution	Accuracy	Measuring Requirement
3813	0.015-1.0mm	0.0001mm for range up to 0.99mm OR 0.001mm for range above 1mm	$\pm 1-3\%$ or 0.002mm (whichever is greater)	-Min area – 5 x 5mm -Min radius – 3mm (convex) and 30mm (concave) -Min thickness – 0.5mm (ferrous) and 0.05mm (non-ferrous)
Standard accessories supplied with 3813	Coating thickness, 1 x steel and 1 x aluminium substrate samples, 4 x thickness samples			

## 3812 ULTRASONIC THICKNESS GAUGE

The 3812 Ultrasonic Thickness Gauge measures the thickness of metallic and non-metallic materials such as steel, aluminium, titanium, plastics, ceramics, glass and any other good ultrasonic wave conductor that has parallel top and bottom surfaces.

This dynamic ultrasonic thickness gauge accurately displays readings in either inch or millimetre units after a simple calibration to a known thickness or sound velocity.

- Upper/lower limit preset alarm.

Cat No	Range	Resolution	Accuracy	Sound velocity range
3812	1-300mm	0.001mm	$\pm(0.5\% \text{ thickness} + 0.025\text{mm})$	1000-9999m/s
Standard Accessories supplied with 3812 Ultrasonic thickness gauge, 1 x cable, 1 x USD cable, 1 x couplant gel.				



3812



# METROLOGY

## SR160 SURFACE ROUGHNESS TESTER

The SR160 is a superior portable surface roughness tester that measures multiple roughness parameters with a 1- button click. Roughness measurement parameters such as Ra, Rz, Rp, Rv and Rt are displayed on a brightly lit intuitive 60mm / 2.4" LCD colour display. Its rechargeable battery operation makes it a convenient way of performing fast, easy and precise on-the-spot measurements in almost any environment and surface.

- Bluetooth technology - quick reliable communication between traverse and display/control unit
- Tactile measurement button, great for challenging orientations
- Splits into a display/control unit and traverse unit via a slide and lock mechanism
- Hard wearing, robust piezo-electric pick-up stylus with diamond tip assures very reliable measurement
- Advanced rechargeable battery for unrivalled reliability and battery life
- Enhanced durability and improved grip provides unbeatable protection in harsh shop floor environments
- Charge from mains or any standard USB charging port
- Instant access to menu options and settings
- Clear detailed graph showing measurement area - excellent for visually identifying defects
- Reference standard included



Cat. No.	Description
SR160	SR160 two-piece surface roughness tester assembly, calibration standard, batteries, operation guide and a carrying case



SR160

Instrument Performance		
Gauge	Resolution	0.01µm (0.4µin) 0.01µm (0.4µin)
	Range (Ra)	Up to 40µm (1600µin) Up to 40µm (1600µin)
	Range (Rz, Rv, Rp, Rt)	Up to 199µm (7800µin) Up to 199µm (7800µin)
Measurement	Repeatability	2 % of value + noise
	Accuracy	5% of reading + 0.1µm (4µin)
	Noise	0.02µm (0.8µin)
	Process	Automated software calibration routine
Calibration	Standard	Able to calibrate to ISO 4287 Roughness Standards
	Standards	ISO 4287 and ASME 46.1
	Parameters	ISO 4287 (Roughness) Ra, Rz, Rp, Rv, Rt, Rz1max, Rsk, Rq, Rku ISO 4287 (Primary) Pa, Pz, Pp, Pv, Pt
Technical		
Data output	On-screen	Up to 5 results per page, selectable on-screen graph
Battery	Charger	Mini USB 5V 1A 110-240 VAC 50/60 Hz
	Charging time	4 hours
	Battery life	> 2000 measurements
Power	Standby time	5000 Hours
	Instant On	Max 5 sec from standby to ready to measure
	Auto-sleep function	5 minutes
Instrument Capability		
Pick-up assembly	Pick-up type	Piezoelectric
	Stylus type	Diamond, Radius 200µin (5µm)
Gauge	Gauge force	200 mg
	Measurement type	Skidded
Filter	Filter type	Gaussian
	Filter cut-off	0.8mm
Traverse	Traverse length	5mm / 0.2in
	Traverse Speed	2mm/sec / 0.08in/sec
Display	Units	µin/µm
Environmental/Physical		
Physical specifications	Weight including pickup	0.4kg / 14 oz
	Power source	Li-Poly rechargeable battery
Operating conditions	Temperature	41-104°F (5-40°C)
	Humidity	0-80% non-condensing
Storage conditions	Temperature	32-122°F (0-50°C)
	Humidity	0-80% non-condensing

# METROLOGY

## SR300 AND SR400 SURFACE ROUGHNESS TESTER

The SR300 and SR400 instruments offer a versatile solution for all your roughness requirements with a variety of systems and application specific accessories along with fixtures that can be tailored to your specific need.

The inclusion of a 50mm stylus lift with right angle attachment and more than 70mm stylus reach means that even the most challenging surfaces can be measured without the need for expensive riser blocks, stands or fixtures. The anti-slip V-feet also mean the system can be used on flat or curved surfaces. The stylus can even measure upside down!

Through its industry standard Type A USB port and mini USB port the SR300 and SR400 Surface Roughness Testers provide extensive connectivity options to many standard devices.

- Large screen display
- Many application specific parameter options
- Comprehensive selection of optional accessories and pickups
- Long traverse length and extended pickup reach
- Stores up to 100 readings
- Anti-slip feet perfect for mounting on flat or curved surfaces
- Rubberised moulding adds protection and better grip in the hand; invaluable in shop floor environments
- Orientation - fix the display in 1 of 4 orientations; perfect for awkward measurements
- Simple Set Up - shortcuts provided for all the key settings to give instant access with just a single touch
- Profile Graph - detailed graph shows measured area to help identify problem areas
- Measure - tactile measurement button, great when device is being used overhead or inside pipes
- Includes traverse unit, TalyProfile Lite software, stylus lift, calibration standard, manual and carrying case

Cat No	Description
SR300	1x SR300 unit, 1 x reference standard, 1 x Standard Pickup with cable
SR400	1x SR400 unit, 1 x reference standard, 1 x Standard Pickup with cable



Measurement Capability	SR300	SR400
Range	200µm, 100µm, 10µm	400µm, 100µm, 10µm
Resolution	100nm, 20nm, 10nm	50nm, 10nm, 5nm
Noise Floor (Ra)	250nm, 150nm, 100nm	150nm, 100nm, 50nm
Gauge Repeatability (Ra)	1% of value + noise	0.5% of value + noise
Pickup Type	Inductive	
Gauge Force	150 - 300mg	
Stylus Tip Radius	5µm (200µin) default/2µm (80µin) or 10µm (400µin) optional	
Measurement Type	Skidded	
Process	Automated software calibration routine	
Standards	Able to calibrate to ISO 4287 roughness standards	
Filter Cut-Off	0.25mm/0.8mm/2.5mm	
Filter Type	2CR/Gaussian	
Analysis Evaluation Length	0.25 - 12.5mm (0.01 - 0.49in)	0.25 - 25.0mm (0.01 - 0.98in)
Max. X Axis Range	17.5mm	25.5mm
Speed Measuring Speed	1mm/sec (0.04in/sec)	
Returning Speed	1.5mm/sec (0.06in/sec)	

Analysis Capability	SR300	SR400
Standards	ISO 4287, ISO 13565-1, ISO 13565-2, ASME 46.1, JIS 0601, N31007	
ISO Basic	Ra, Rv, Rp, Rz, Rt, Rq, Rsk, Rmr, Rdq, Rpc, RSm, Rz1max	
ISO Advanced	Optional	Rk, A1, A2, Mr1, Mr2, Rpk, Rvk
ASME	Ra, Rv, Rp, Rz, Rt, Rq, Rsk, Rdq, RSm, Rpm, Rda	
JIS	Ra, Rv, Rp, Rz, Rt, Rq, Rsk, Rmr, Rdq, RSm, RzJIS, Rc, Rku, Rdc	
Other	R3z (Daimler Benz)	
ISO Primary	Optional	Pa, Pv, Pp, Pz, Pt, Pq, Psk, Pmr, Pdq, Ppc, PSm, Pz1max
Units	µm/µin	

SR300 and SR400 Surface Roughness Tester and Accessories	
Cat. No.	Description
SR300	SR300 display and 17.5mm traverse unit
SR400	SR400 display and 25mm traverse unit
SR-112-1510	200mm / 7.875" extension rod with lead
SR-112-1534	Reference standard
SR-112-1517	Support stand
SR-112-2693	Column and standard
SR-112-1502	Standard pickup with 200µ"/5µmm stylus
SR-112-1503	Standard pickup with 400µ"/10µm stylus
SR-155-P28495	Small bore pickup
SR-112-1505	Right angle pickup
SR-112-1506	Recess Pickup
SR-112-3680	TalyProfile Gold - 2D analysis software with cable
SR-112-3681	TalyProfile Silver - 2D analysis software with cable
SR-K509-1578	TalyProfile 8'/2.5m cable
SR-K509-1820	TalyProfile 5'/1.5m cable
SR-112-4570	USB thermal printer
SR-112-4571	Thermal paper
SR-112-4545	Plug adaptors
252Z-14	252 height transfer gauge
PT99560	Clamp to attach SR300 and SR400 to 252 height transfer gauge

## TALYPROFILE

### ADVANCED SURFACE FINISH ANALYSIS

TalyProfile is a dedicated PC based software package designed for use with the SR300 and SR400 instruments. Three versions are available. TalyProfile "Lite" has all functions typically used for a shopfloor inspection. TalyProfile "Silver" has enhanced features for R&W parameters, a statistics module and full report printing. TalyProfile "Gold" has complete laboratory analysis functions.

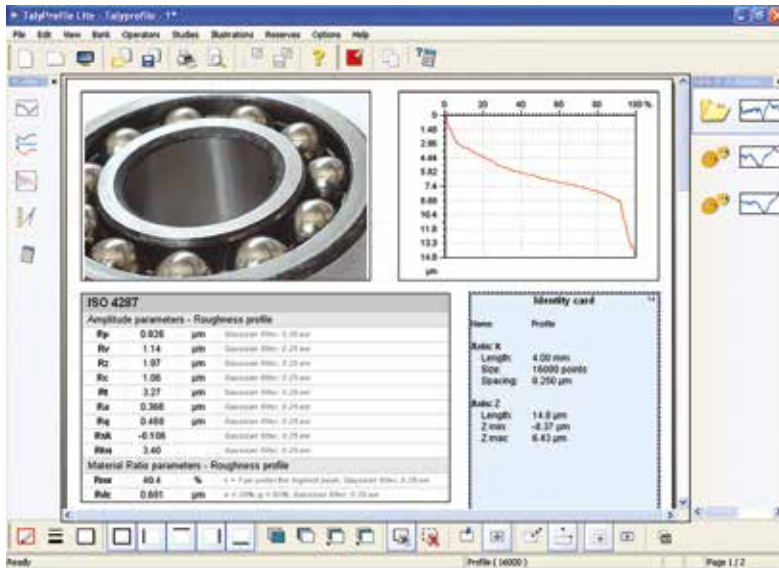

TalyProfile	Lite	Silver	Gold
Surtronic S-series acquisition	X	X	X
Desktop publishing templates	X	X	X
Multi-language support	X	X	X
EN, FR, DE, ES, IT, PL, CN, KR	X	X	X
Levelling	X	X	X
Symmetries	X	X	X
Zoom	X	X	X
ISO 4287	X	X	X
Material Ratio Curve	X	X	X
Area of a hole/peak	X	X	X
Profile parameters and curves	X	X	X
Roughness and waviness curves	X	X	X
Distance measurement	X	X	X
Multiple file format reports		X	X
Report printing		X	X
Form Talysurf data import		X	X
Tolerance limits (pass/fail)		X	X
Data file explorer		X	X
ISO 13565 Automotive		X	X
Interactive Mr curve		X	X
Step height measurement		X	X
Form removal			X
Filtering by FFT			X
Thresholding			X
Frequency spectrum			X
Power spectrum density			X
Retouch profile point			X
Rk parameters			X
Rk parameters curves			X
ISO 12085 R&W motifs			X

#### TALYPROFILE PARAMETERS

Roughness parameters obtained by filtering: Ra, Rq, Rt, Rp, Ry, Rku, Rsk, RSm, Rz, RΔq, RTP, RHTp, Rlo, RPC, RzJIS, Rz3z

Parameters on the raw profile (unfiltered): Pa, Pq, Pt, Pp, Pv, Pku, Psk, PSm, Pz, PΔq, PTP, PHTp, PLo, PPC

Parameters obtained by double filtering (DIN 4776): Rk, Rpk, Rvk, MR1, MR2, A1, A2, Rpk,

Parameters obtained by the motifs method ("R&W"): R, AR, Pt, Rx, SR, SAR, Nr, Kr, W, AW, Wte, Wx, SW, SAW, Nw, Kw, Rke, Rpk, Rvke, Trc, HTrc

\* Only with gold or silver versions

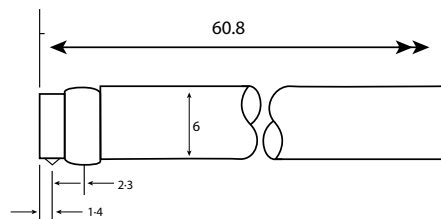

Standard Pick-Up  
for general surface roughness measurement  
Code SR-112-1502 (5µm tip radius)  
Code SR-112-1503 (10µm tip radius)

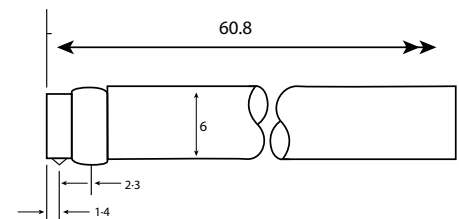

Right Angle Pick-Up  
for measurement at right angles to the direction of traverse  
Code SR-112-1505

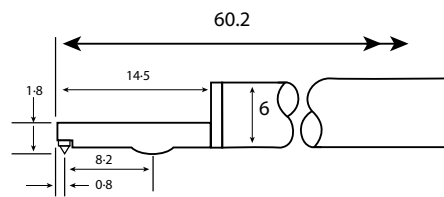

Small Bore Pick-Up  
for general use in small bores, grooves and on narrow surfaces  
Code SR-155-P28495

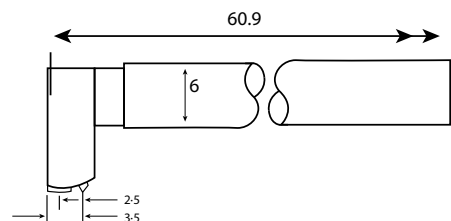

Recess Pick-Up  
for measuring into deep recess  
Code SR-112-1506 recess 5.7mm (0.23")

All measurements in mm

# METROLOGY

## RT500 AND RT800 ROUNDNESS TESTERS

A range of roundness products robust enough for the shop floor but accurate enough for any inspection room.

Full ISO compliant measurements can be taken with  $\pm 25\text{nm}$  accuracy and 30nm gauge resolution. The X-sight touch screen software platform with intuitive navigation makes the roundness system as easy to use as a Sat Nav or Smart Phone with everything you need at your fingertips.



Model number	RT500	RT800
Standard accessories supplied with the Roughness tester	1 x Roughness tester, 1 x X-sight touch screen controller, 1 x probe arm	
Measuring capacity	Max diameter	300mm / 11.8"
	Max height	280 mm / 11"
	Max weight	20 Kg / 44 lb
Work table	Diameter, standard	125mm / 4.9"
	Diameter, accessory	300mm/11.8"
	Centring	$\pm 1.25 \text{ mm } \pm 0.049''$
	Levelling	30 arc minutes
Spindle	Height of neutral plane	51 mm / 2"
	Speed of rotation	15 Rpm Max
	Radial limit of error (departure from the LS circle)	$\pm 25 \text{ nm } @ 6 \text{ Rpm}$
Gauge	Range	2 mm / 0.079"
	Resolution	30 nm
Filter	Type	None, Gaussian, Robust Gaussian, 2 CR-PC, Fourier
	Standard filter cut-offs	1-15 upr, 1-50 upr, 1-150 upr, 15-150 upr, 1-500 upr, 15-500 upr
	Special filters	User selectable & Bandpass
	System features	Roundness/flatness
	Coaxiality, eccentricity,	✓
	Concentricity, radial runout	✓
	Squareness	✓
	Parallelism	✓
	Measure interrupted surfaces	Optional
	Thickness variation	Optional
	Centring attachment 200 mm	Optional

All accuracies and uncertainties are quoted at 68°F  $\pm 1.8^\circ\text{F}$  (20°C  $\pm 1^\circ\text{C}$ ) with 1-50  $\mu\text{pr}$  Gaussian filter at 6 rpm.

### ENVIRONMENT AND SERVICE REQUIREMENT FOR RT500 AND RT800

Electrical supply	Environmental conditions		Air source requirements	
Alternating supply, single phase with earth (3 wire system)	Temperature:	Operating 50°F - 95°F (10°C - 35°C)	Free air flow rate:	39.4 in/sec maximum steady (1.0 m/sec)
Voltage: 90 - 260 V	Temp / time gradient:	less than 3.6°F/hour (2°C)	Maximum source pressure:	120 psi (8.1 bar)
Frequency: 47 - 63 Hz	Humidity operating:	30 % to 80 % relative, non-condensing	Minimum source pressure:	80 psi (5.4 bar)
Consumption (total system): 250 VA max, 160 W	Storage:	10 % to 90 % relative, non-condensing	Air consumption:	1.3 cfm/min (0.037 cu.m)
<b>Weight (without fixtures)</b> 35kg / 77lbs			Operating pressure:	60 psi (4.1 bar)
			Filtering:	200 $\mu\text{in}$ (5 $\mu\text{m}$ )
			Moisture content – dewpoint: 3	5.6 °F (2 °C)

# METROLOGY

## ACCESSORIES FOR RT500 AND RT800

### 1. FLICK STANDARD

- For rapid calibration of gauge head sensitivity; alternative to the gauge calibration set.
- 300  $\mu\text{m}$  / 0.012" range
- Cat No. RT800-2233 optional

### 2. SIX JAW COMPONENT CHUCK

- A 6-jaw precision scroll chuck
- Capacity – Inside diameter
- 20 mm – 95 mm / 0.78–3.7"
- Capacity – Outside diameter
- 2 mm – 32 mm / 0.08 –1.26"
- Cat No. RT800-1859 optional

### 3. GLASS HEMISPHERE

- For checking overall system performance. UKAS calibration certificate is optional
- Roundness < 0.05  $\mu\text{m}$  / 2  $\mu\text{m}$
- Cat No. RT-436 optional

### 4. CALIBRATION SET

- For calibrating the gauge head. Comprises a circular glass flat and three gauge blocks
- (2.5 mm, 2.8 mm and 3 mm). UKAS calibration certificate is optional
- Cat No. RT-1874 optional

### 5. CRESTING PIN

- For checking the vertical and horizontal alignment of the gauge head
- Cat No. RT-1876 optional

### 6. MAGNETIC FIXTURE WITH CENTRING ATTACHMENT

- 200 mm internal clamping (max diameter)
- 80 mm external clamping
- Cat No. RT800-4313 optional

### SPECIAL REQUESTS

- We can also provide customised products which are designed to exactly match your requirements. These include work components with specific dimensions and special styli for applications such as small holding devices for bores, shoulders or undercuts. Other speciality accessories include stylus arms, precision collet chucks and collets, reservoir assembly kit, pre filter element and kinematic dowel support set

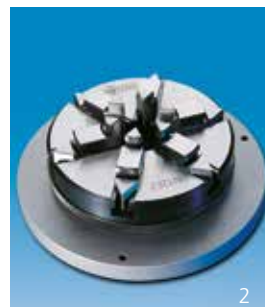

# METROLOGY

## ANALYSIS FOR ROUGHNESS MEASUREMENT

Type of analysis	Measurement mode	Evaluation diagram	RT500	RT800
Roundness			✓	✓
Flatness			✓	✓
Concentricity			✓	✓
Eccentricity			✓	✓
Axial			✓	✓
Radial			✓	✓
Coaxiality			✓	✓
Squareness			✓	✓
Parallelism			✓	✓
Measure Interrupted Surface			Optional	✓
Axial			Optional	✓
Thickness Variation			Optional	✓

# OPTICAL PROFILE PROJECTORS

## HE400

### HORIZONTAL BENCH TOP OPTICAL PROFILE PROJECTOR

The most economical of our benchtop horizontal projectors, this machine offers a 400mm / 16" screen, 250 x 100mm / 10 x 4" workstage, bayonet fitting lenses and Q-axis angular readout; all to improve capacity and performance. These latest horizontal projectors are fitted with either Quadra-Chek® digital readout systems or MetLogix™ M1 or M2 software as standard, making them simple to use, but having the power to satisfy the most complex measuring requirements.

The HE400 comes with a bayonet socket that can accommodate one of five interchangeable projection lenses. Purchase of the OV2 video adapter can also convert system operation from profile projector to video metrology system, subject to a suitable video enabled digital readout.



- Fully usable 400mm / 16" diameter screen with precision cross lines, overlay clips and integral hood
- Large measuring travel: 254mm / 10" X-axis, 100mm / 4" Y-Axis
- Fully retractable duplex fibre optic surface illumination
- Fine adjustment on all axes, plus zero backlash, fast traverse mechanism on the X-axis
- Lamphouse mounted helix adjustment for accurate threadform inspection
- High precision workstage with 480 x 120mm / 18.9 x 4.7" top plate, with machined slot for easy fixturing
- Stage weight capacity: 25kg /55lbs (evenly distributed)
- Screen driven rotary Q axis
- 0.001mm resolution linear Heidenhain scales
- Automatic edge detection option
- All Starrett Optical Profile Projectors have lens magnifications set and calibrated to the following accuracies:  
Profile:  $\pm 0.05\%$ .  
Surface Illumination:  $\pm 0.10\%$ .

#### HE400 DIMENSIONS

HE400 dimensions are as listed in the image, all measurements are in millimetres.

- Gross Weight: 135kg
- Nett Weight: 105kg
- Shipping dimensions: 120 x 80 x 127cm

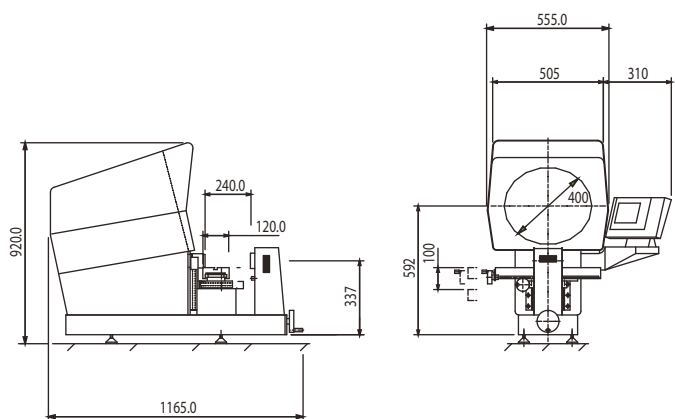

# OPTICAL PROFILE PROJECTORS

## VB400

### VERTICAL BENCH TOP OPTICAL PROFILE PROJECTOR

The VB400 vertical optical projector allows flat parts to be simply laid on a glass insert in the workstage. Features include a 400mm / 16" diameter vertical screen, ultra-bright LEDs for long-life illumination, linear encoder scales for 0.5µm / .00002" resolution, and angular readout to better than 1' resolution. Available with stages with 200 x 100mm / 8" x 4" of XY travel. Options include six projection lenses from 10x to 100x and a choice of digital interfaces.



- Fully usable 400mm / 16" diameter vertically mounted screen with precision cross lines, overlay clips and integral hood
- Large measuring travel: 200mm / 8" X-axis, 100mm / 4" Y-Axis
- Fast traverse, quick release mechanism on X and Y axis
- LED profile lighting and LED surface illumination fitted as standard
- High precision workstage with 400 x 225mm / 16 x 8.875" top plate, with two machine slots for easy fixturing
- Stage weight capacity: 10kg / 22lbs (evenly distributed)
- Screen driven rotary Q axis
- 0.001mm resolution linear scales, upgrade to Heidenhain scales available as an option
- Automatic edge detection option
- All Starrett Optical Profile Projectors have lens magnifications set and calibrated to the following accuracies:  
Profile:  $\pm 0.05\%$ .  
Surface Illumination:  $\pm 0.10\%$ .

#### VB400 DIMENSIONS

VB400 dimensions are as listed in the image, all measurements are in millimetres.

- Gross Weight: 170kg.
- Nett Weight: 145kg.
- Shipping dimensions: 120 x 80 x 146cm.

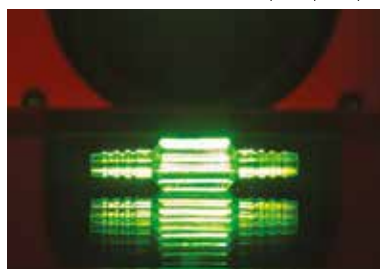
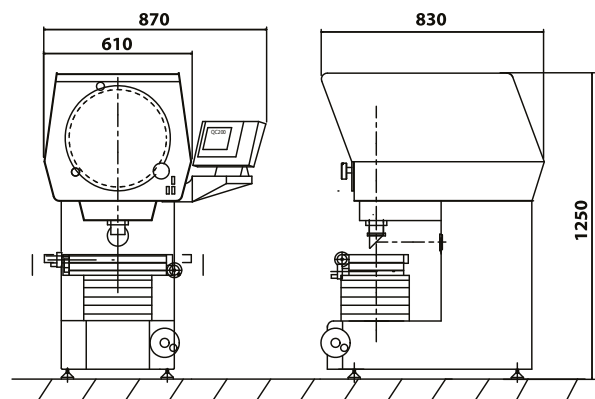



# OPTICAL PROFILE PROJECTORS

## ACCESSORIES

### HE400

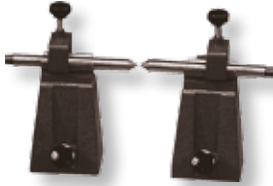

Part No	Description
4G000	Precision Centres and Vees



Part No	Description
7U000	Vertical Glass Plate Holder



Part No	Description
4U000	Magnification Check Graticule



Part No	Description
4H003	32mm Capacity Rotary Vice



Part No	Description
4H002	32mm Capacity Fixed Vice



Part No	Description
4H004	Universal Rotary Vee Block



Part No	Description
7R000	Standard Projector Support Cabinet with single fixed shelf.



## ACCESSORIES

### VB400



Part No	Description
3V000	Helix Centre Support Fixture

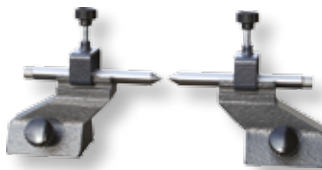

Part No	Description
6H000	Precision Centres and Vees



Part No	Description
10L000	Standard Projector Support Cabinet with single fixed shelf.



Part No	Description
6U003	Precision Rotary Workstage



# OPTICAL PROFILE PROJECTORS

## M1 AND M2

### FOR OPTICAL PROFILE PROJECTORS

Graphics rich display, large icon buttons, and intuitive operation. Coordinate display for X and Y linear axes and Q radius values for screen rotation. Easy part alignment and datum function.

- Clean and simple touchscreen interface with large icon buttons and intuitive operation
- Graphics-rich display providing instant information on feature form, tolerances, and measurement data
- Coordinate display for X and Y linear axes and Q radius values for screen rotation
- Easy part alignment and datum functions
- Measure and tolerance these geometric features: point, line, angle, distance, radius, diameter
- As you measure, a part view is created in the feature view. Constructions between features such as distances and bolt hole pattern can be done by simple selections from the part view
- For repetitive part measurement, create a part program that will visually guide operators through part measurement
- Available optical edge detection provides better throughput and removes operator subjectivity
- Four different report forms can be printed or exported to Microsoft Excel, text files, or to an SPC program
- Mounts and displays in either vertical or horizontal position
- M2 utilizes a Windows® 7 Professional-based operating system enabling flexible data export and interface capability with Windows
- Fast, easy connection to printers and networks
- M1 utilizes an Android operating system and a Bluetooth connection to the host Optical Projector



M2

	MetLogix M1	MetLogix M2
Mounted to comparator arm	x	x
Colour graphics	x	x
Touch-screen operation	x	x
MS Windows® operating system		x
X-Y-Q (angle) measurements	x	x
2D geometry software with skew	x	x
Optical edge detection option	x	x
Video edge detection option		
CAD file import and export option		x
CNC drive option		x

## QC200 QUADRA CHEK

QC200 is a time-saving measurement tool with patented Measure Magic® technology. Ideal for measuring 2D features on Optical Projectors and Manual Vision Machines.

- Inch / metric conversion, toggle between incremental/absolute and simple zero reset
- Skew function for ease of part alignment
- Integrated geometric tolerancing allowing for pass/fail measurements
- Simple part programming with measure guide
- USB and RS232 Interface
- Linear and segmented linear error correction
- Intuitive displays
- Crisp, clear, bright black and white LCD display
- Optional optical edge for profile projectors



M1



QC200

# INDEX

<b>BORE GAUGES .....</b>	<b>23 - 30</b>	<b>INDICATOR STANDS.....</b>	<b>38</b>
• Bore Gauge Heads.....	27 - 28	<b>INSTRUMENT OIL .....</b>	<b>42</b>
• Bore Gauge Systems.....	29 - 30	<b>LAYOUT DYE .....</b>	<b>42</b>
• Dial Bore Gauges.....	24	<b>LEVELS.....</b>	<b>45</b>
• Electronic Bore Gauges.....	26	<b>MICROMETERS.....</b>	<b>15 - 22</b>
• Hole Gauges.....	23	• Anvil Micrometers.....	18
• Mechanical Bore Gauges.....	25	• Bench Micrometers.....	22
• Telescoping Gauges.....	23	• Blade Micrometers.....	19
<b>CALIPERS .....</b>	<b>06 - 09</b>	• Can Seam Micrometers.....	18
• Carbon Fibre Calipers.....	08 - 09	• Depth Micrometers.....	23
• Dial Calipers.....	6	• Disc Micrometers.....	20
• Electronic Calipers.....	7	• Inside Micrometer Sets.....	21
• Vernier Calipers.....	5	• Outside Micrometers.....	15
<b>CENTRE PUNCHES .....</b>	<b>43</b>	• Electronic Outside Micrometers.....	16 - 17
<b>COMBINATION SETS .....</b>	<b>46</b>	<b>OPTICAL PROFILE .....</b>	<b>63 - 66</b>
<b>DEPTH GAUGES.....</b>	<b>10 - 11</b>	<b>PROJECTORS</b>	
• Electronic Depth Gauges.....	10 - 11	• Accessories for Optical Profile Projectors.....	65
<b>DUROMETER .....</b>	<b>56</b>	• Digital Readouts for Optical Profile Projectors.....	66
<b>EDGE FINDERS.....</b>	<b>42</b>	• HE400 Horizontal Bench Top Optical.....	63
<b>FIXED GAUGES .....</b>	<b>39 - 41</b>	Profile Projector	
• Screw Pitch Gauges.....	40	• VB400 Vertical Bench Top Optical.....	64
• Taper Gauges.....	39	Profile Projector	
• Thickness Gauges.....	39	<b>PARALLELS.....</b>	<b>46</b>
• Thickness Gauges / Feeler Stock.....	41	<b>PUNCHES AND.....</b>	<b>44</b>
<b>GAUGE BLOCK SETS..</b>	<b>47 - 49</b>	<b>PUNCH SETS</b>	
<b>HARDNESS TESTERS.....</b>	<b>51-55</b>	<b>ROUGHNESS .....</b>	<b>57 - 59</b>
• Bench Hardness Testers.....	51	<b>TESTER</b>	
• Portable Hardness Testers.....	54 - 55	<b>ROUNDNESS.....</b>	<b>60 - 62</b>
• Test Blocks and Accessories.....	52 - 53	<b>TESTER</b>	
• Ultrasonic Thickness Gauge.....	56	<b>SLIDE CALIPERS -.....</b>	<b>06 - 09</b>
<b>HEIGHT GAUGES .....</b>	<b>11 - 14</b>	<b>SEE CALIPERS</b>	
• Dial Height Gauge.....	11	<b>SQUARES.....</b>	<b>46</b>
• Electronic Height Gauges.....	12 - 14	<b>VIDEO BORESCOPIES .....</b>	<b>50</b>
<b>INDICATORS .....</b>	<b>31 - 37</b>		
• Back Plunger Indicators.....	35		
• Dial Indicators.....	31		
• Electronic Indicators.....	33 - 34		
• Mechanical Test Indicators.....	32		
• Special Function Indicators.....	36 - 37		

## STARRETT PRODUCT LINES...

POWER TOOL ACCESSORIES & HAND TOOLS

JOBSITE & WORKSHOP TOOLS

BAND SAW BLADES & MACHINES

PRECISION MEASURING TOOLS

WEBBER GAUGE BLOCKS

METROLOGY EQUIPMENT

LASER MEASUREMENT

PRECISION GRANITE

PRECISION GROUND SOLUTIONS

ROUNDNESS MEASUREMENT

FORCE MEASUREMENT

SERVICE & TECHNICAL SUPPORT

# PRECISION TOOLS

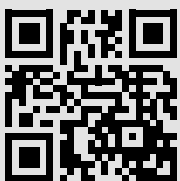

[www.starrett.com](http://www.starrett.com)

# Starrett®

Tel: 65 63651088 | Fax: 65 63655125

E mail: [Starrett\\_asia@starrett.com.sg](mailto:Starrett_asia@starrett.com.sg)

Starrett (Asia) Pte Ltd., 11 Woodlands Close, #07-45, Singapore (737853)

[www.starrett.com](http://www.starrett.com)

Catalogue 33E Precision Tools The L.S. Starrett Company 2015© Specifications subject to change