

HFV15-SH

AUTOMOTIVE RELAY



Typical Applications

Fog lamp & headlight control, Hazard warning flasher control, Rear window & mirror defogger, Air-conditioning, Fuel pump control, Cooling fan control.

Features

- Contact type: SH, two types of wiring methods, a: double NO contacts; b: H-bridge, one NO contact.
- Wiring method a: 2x25A contact switching capability, maximum continuous current 2x25A(at 85°C)
- Wiring method b: 54VDC contact switching capability, maximum continuous current 40A(at 85°C)
- Plastic sealed and dust protected types available
- RoHS & ELV compliant

CHARACTERISTICS

Contact arrangement	1U
Voltage drop	Typ.: 20mV (at 10A) Max.initial :100mV (at 10A) Max.after test : 250mV(at 10A)
Max. continuous current ¹⁾⁹⁾	Wiring method a:2x32A(at 23°C) 2x25A(at 85°C),2x11A(at 125°C) Wiring method b: 60A (at 23°C) 40A (at 85°C),17A (at 125°C)
Max. switching current ⁹⁾	Wiring method a:Make 2 x100A ²⁾ Break : 2x25A (Resistive, 13.5VDC) Wiring method b:Make 60A ³⁾ Break : 25A (Resistive, 54VDC)
Min. contact load	1A 6VDC
Electrical endurance	See "CONTACT DATA"
Mechanical endurance	1 x 10 ⁶ OPS (300OPS/min)
Initial insulation resistance	100MΩ (at 500VDC)
Dielectric strength ⁴⁾	between contacts: 500VAC between coil & contacts: 500VAC
Operate time ⁹⁾	Max.: 10ms (at nomi. vol.)
Release time ⁵⁾⁹⁾	Max.: 10ms
Ambient temperature	-40°C to 125°C

Vibration resistance ⁶⁾⁹⁾	5Hz to 22.3Hz 10mm DA 22.3Hz to 500Hz 98m/s ²
Shock resistance ⁶⁾⁹⁾	294m/s ²
Flammability ⁷⁾	UL94-HB or better (meets FMVSS 302)
Termination	QC
Construction	Plastic sealed,Dust protected
Unit weight	Approx. 35g
Mechanical data	cover retention (pull & push): 200N min. terminal retention (pull & push): 100N min. terminal resistance to bending (front & side): 10N min. ⁸⁾

- 1) Measured when applying 100% rated voltage on coil.
- 2) Inrush peak current under lamp load, at 13.5VDC.
- 3) Motor load peak current,54VDC.
- 4) 1min, leakage current less than 1mA.
- 5) The value is measured when voltage drops suddenly from nominal voltage to 0 VDC and coil is not paralleled with suppression circuit.
- 6) When energized, opening time of NO contacts shall not exceed 100us.
- 7) FMVSS: Federal Motor Vehicle Safety Standard.
- 8) Test point is at 2mm away from terminal end, and after removing testing force, the terminal transfiguration shall not exceed 0.5mm.
- 9) Only for the 12VDC coil voltage type.

CONTACT DATA ¹⁾

Load voltage	Load type		Load current A			On/Off ratio		Electrical endurance ²⁾ OPS	Contact material	Load wiring diagram ³⁾	Ambient temp.		
			1U		1A	On s	Off s						
			NO1	NO2	NO								
13.5VDC	Resistive	Make	25	25	-	2	2	1×10 ⁵	AgSnO ₂	Wiring method a diagram 1	-40°C~125°C see ambient temperature curve of the electrical endurance test		
		Break	25	25	-								
	Lamp	Make	100 ⁴⁾	100 ⁴⁾	-	2	2		1×10 ⁵			AgSnO ₂	Wiring method a diagram 2
		Break	100	20	-								



HONGFA RELAY

ISO9001, ISO/TS16949, ISO14001, OHSAS18001, IECQ QC 080000 CERTIFIED

2017 Rev. 1.00

CONTACT DATA¹⁾

Load voltage	Load type		Load current A			On/Off ratio		Electrical endurance ²⁾ OPS	Contact material	Load wiring diagram ³⁾	Ambient temp.
			1U		1A	On s	Off s				
			NO1	NO2	NO						
13.5VDC	Inductive	Make	40	40	-	2	2	1×10^5	AgSnO ₂	Wiring method a diagram 3	-40°C~125°C see ambient temperature curve of the electrical endurance test
		Break	20	20	-						
27VDC	Resistive	Make	15	15	-	2	2	1×10^5	AgSnO ₂	Wiring method a diagram 1	
		Break	15	15	-						
54VDC	Resistive	Make	-	-	25	2	2	1×10^5	AgSnO ₂	Wiring method b diagram 4	
		Break	-	-	25						
	Inductive	Make	-	-	60	2	2	1×10^5	AgSnO ₂	Wiring method b diagram 5	
		Break	-	-	20						

1) Loads mentioned in this chart is for relays with no parallel diode or Zener Diode. For those with parallel diode, Zener Diode or other components, please contact Hongfa for more technical supports.

Please also contact Hongfa if the actual application load is different from what mentioned above.

2) The low resistive or diode suppression device in parallel to the relay coil increases the release time and reduces the life time caused by increased erosion and / or higher risk of contact welding.

3) The load wiring diagrams are listed below.

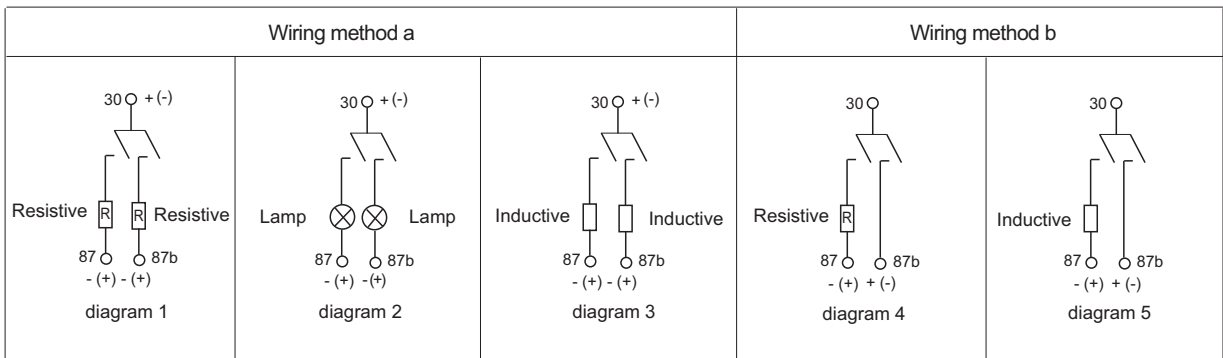

4) Corresponds to the peak inrush current on initial actuation (cold filament).

COIL DATA

at 23°C

Nominal voltage VDC	Pick-up voltage VDC max.	Drop-out voltage VDC min.	Coil resistance x(1±10%)Ω	Parallel resistance ¹⁾ x(1±5%)Ω	Equivalent resistance Ω	Power consumption W	Max. allowable overdrive voltage ²⁾ VDC	
							at 23°C	at 85°C
12	7.2	1.2	90	---	---	1.6	20.2	15.7
12	7.2	1.2	90	680	79.5	1.8	20.2	15.7
24	16	2.4	320	---	---	1.8	40.5	31.5
24	16	2.4	320	2700	286	2.0	40.5	31.5

1) Illustrated with the type with parallel resistor (680Ω, 12V), (2700Ω, 24V).

2) Max. allowable overdrive voltage is stated with no load applied, illustrated with dust cover version.

ORDERING INFORMATION

HFV15 / 12 -SH 1 S T J -R (XXX)	
Type	
Coil voltage	12: 12VDC 24: 24VDC
Contact arrangement	SH: 1 Form U
Version	1: QC Terminal
Construction ¹⁾	S: Plastic sealed ²⁾ Nil: Dust protected
Contact material	T: AgSnO ₂
Terminal	J: QC Terminal without hole Nil: QC Terminal with hole, or PCB type
Parallel coil ³⁾ components	R: Parallel transient suppression resistors(680Ω, 12V) (2700Ω,24V) R1: Parallel transient suppression resistors(560Ω, 12V) (1200Ω,24V) D: Parallel transient suppression diode, with anode connected to terminal#85 D1: Parallel transient suppression diode, with anode connected to terminal#86 Nil: Without parallel components
Special code ⁴⁾	XXX: Customer special requirement Nil: Standard

Notes: 1) Dust protected version is recommended.

2) Contact is recommended for suitable condition and specifications if water cleaning or surface process is involved in assembling relays on PCB.

3) If the switch-off peak voltage of coil is required to be smaller than 100V, R1 shall be used (measured voltage of 12V is 13.5V);
If parallel diode, Zener Diode or other components are required, please contact Hongfa for more technical supports.

4) The customer special requirement express as special code after evaluating by Hongfa. e.g. (170) stands for flasher load.

OUTLINE DIMENSIONS AND WIRING DIAGRAM

Unit: mm

Outline Dimensions

HFV15/□□-SH1□T□-□□(XXX)

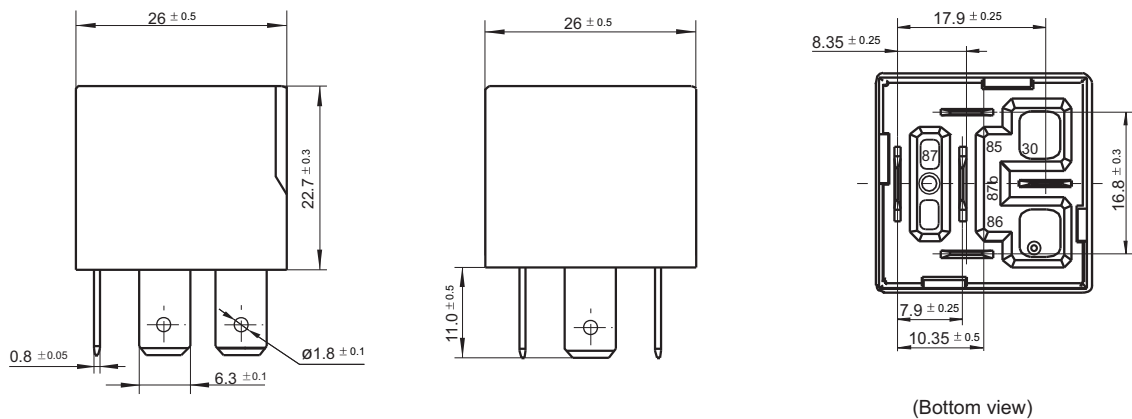

Wiring Diagram

Wiring method a :

HFV15/□□-SH1□T□(XXX)

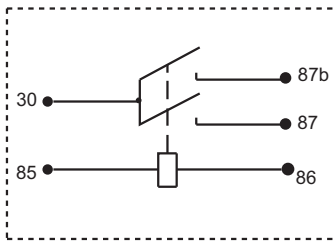

HFV15/□□-SH1□T□-R(XXX)

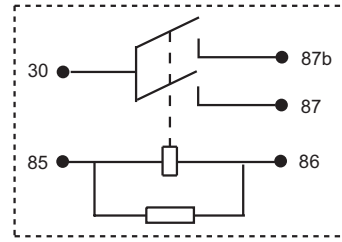

HFV15/□□□-SH1□T□-D(XXX)

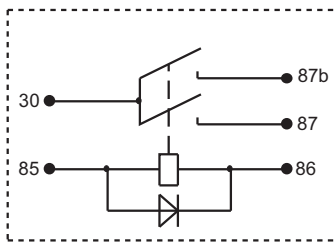

HFV15/□□-SH1□T□-D1(XXX)

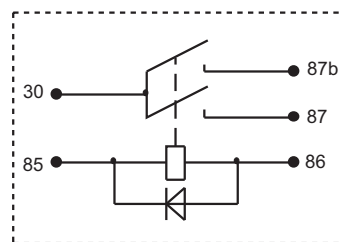

Wiring method b :

HFV15/□□-SH1□T□(XXX)

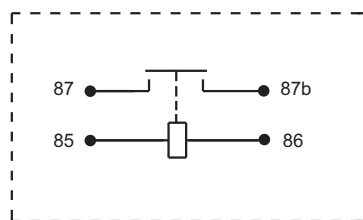

HFV15/□□-SH1□T□-R(XXX)

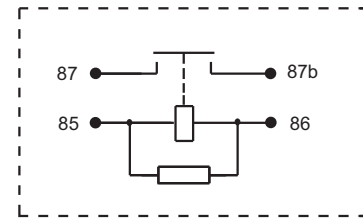

HFV15/□□-SH1□T□-D(XXX)

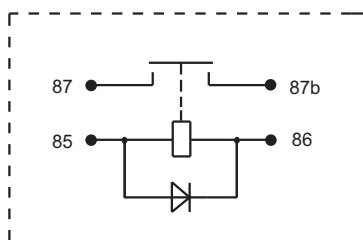

HFV15/□□-SH1□T□-D1(XXX)

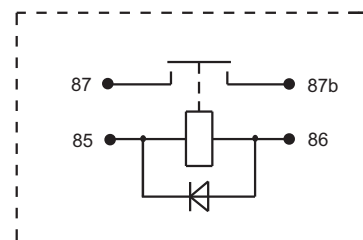

CHARACTERISTIC CURVES

1. Coil operating voltage range

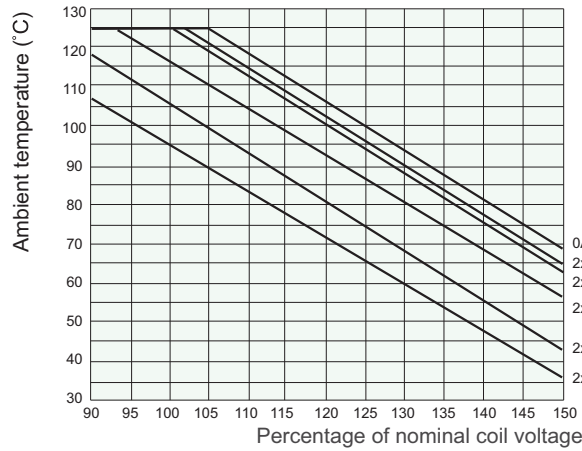

- 1) There should be no contact load applied when maximum continuous operation voltage is applied on coil.
- 2) This chart takes dust protected, 12VDC coil voltage version as example.
- 3) The maximum allowable coil temperature is 180°C. Considering the coil temperature rise which is measured by resistance is average value, we recommend the coil temperature should be below 170°C under the different application ambient, different coil voltage and different load etc.
- 4) If the actual operating coil voltage is out of the specified range, please contact Hongfa for further details.

2. Load-separating capability curve(23°C)

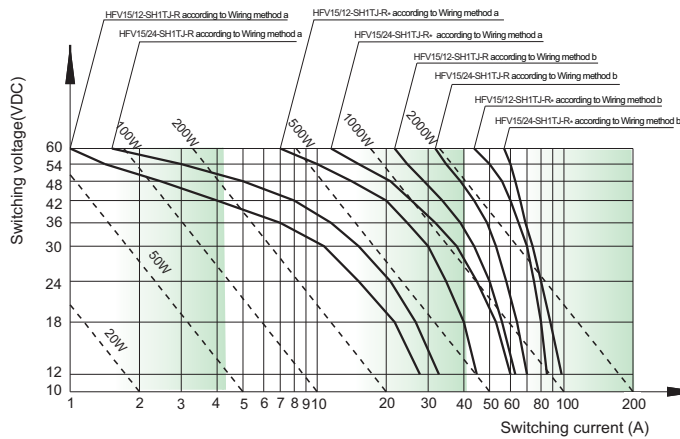

- 1) This chart takes NO contact as an example, the wiring method a just measured the load-separating capability of one of the double NO circuits, the one of the other circuit can take it as reference.
- 2) The sampling points on the load-separating capability curve of this chart, obtained by successfully separating 1000 times of 1mH return circuit inductance.
- 3) This chart is just for reference, if any of the actual using load voltage, current, pick-up frequency, electrical endurance cycle and so on is difference from the condition of this chart, please re-make the confirmation test.
- 4) "HFV15/12-SH1TJ-R*" "HFV15/24-SH1TJ-R*" .
" * " means with magnetic blow-out structure. If customers have any application demand, please contact Hongfa to obtain more technical support.

3. Ambient temperature curve of the electrical endurance test

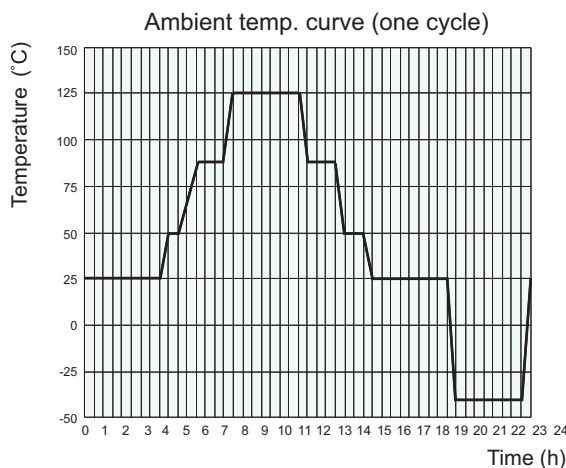

- 1) The minimum temperature is -40°C.
- 2) The maximum temperature is 125°C.

Disclaimer

The specification is for reference only. See to "Terminology and Guidelines" for more information. Specifications subject to change without notice. In case there is specific criterion (such as mission profile, technical specification, PPAP etc.) checked and agreed by and between customer and Hongfa, this specific criterion should be taken as standard regarding any requirement on Hongfa product. We could not evaluate all the performance and all the parameters for every possible application. Thus the user should be in a right position to choose the suitable product for their own application. If there is any query, please contact Hongfa for the technical service. However, it is the user's responsibility to determine which product should be used only.

© Xiamen Hongfa Electroacoustic Co., Ltd. All rights of Hongfa are reserved.