

HF166F

MINIATURE HIGH POWER LATCHING RELAY



File No.:E133481



File No.:R50280244



Features

- Latching relay
- 4mm contact gap available
- 25A switching capability
- 5kV dielectric strength(between coil and contacts)
- Creepage distance between coil and contacts:10mm
- Product in accordance to IEC 60335-1 available
- UL insulation system: Class F
- 1A + 1B configuration for power switching
- Flux proofed type available
- Outline Dimensions: (50.0 x 27.0 x 20.0) mm

CONTACT DATA

Contact arrangement	1A+1B
contact gap	4mm min.
Contact resistance	100mΩ max.(at 1A 6VDC)
Contact material	AgSnO ₂
Contact rating (Res. load)	25A 277VAC
Max. switching voltage	277VAC
Max. switching current	25A
Max. switching power	6925VA
Mechanical endurance	6 x 10 ⁵ OPS
Electrical endurance	3 x 10 ⁴ OPS (NO or NC, 25A 277VAC, Resistive load, at 85°C, 1s on 9s off)

CHARACTERISTICS

Insulation resistance	1000MΩ (at 500VDC)	
Dielectric strength	Between coil & contacts	5000VAC 1min
	Between open contacts	2000VAC 1min
Surge voltage (between coil & contacts)	10kV (1.2/50μs)	
Set time (at nomi. volt.)	25ms max.	
Reset time (at nomi. volt.)	25ms max.	
Shock resistance	Functional	100m/s ²
	Destructive	1000m/s ²
Vibration resistance	10Hz to 55Hz 2mm DA	
Humidity	5% to 85% RH	
Ambient temperature	-40°C to 85°C	
Termination	PCB	
Unit weight	Approx. 45g	
Construction	Flux proofed	

Notes: 1) The data shown above are initial values.

COIL

Coil power	1 coil latching: 1.2W 2 coils latching: 2.4W
------------	---

COIL DATA

at 23°C

1 coil latching

Nominal Voltage VDC	Set Voltage VDC max.	Pulse width (ms) min.	Reset Voltage VDC max.	Coil Resistance Ω
5	4	150	4	20.8x (1±10%)
6	4.8	150	4.8	30x (1±10%)
12	9.6	150	9.6	120x (1±10%)
24	19.2	150	19.2	480x (1±10%)
48	38.4	150	38.4	1920x (1±10%)

2 coils latching

Nominal Voltage VDC	Set Voltage VDC max.	Pulse width (ms) min.	Reset Voltage VDC max.	Coil Resistance Ω
5	4	150	4	10.4x (1±10%)
6	4.8	150	4.8	15x (1±10%)
12	9.6	150	9.6	60x (1±10%)
24	19.2	150	19.2	240x (1±10%)
48	38.4	150	38.4	960x (1±10%)

SAFETY APPROVAL RATINGS

UL/CUL	25A 277VAC/250VAC/125VAC at 85°C 25A 60VDC at 85°C 0.5A 240VDC at 85°C
TÜV	25A 400VDC, at 85°C, ON:5S, OFF:5S, Contacts break without load 70A 72VDC, at 85°C, ON:0.3S, OFF:9S, Contacts break without load 25A 277VAC/250VAC/125VAC at 85°C 25A 60VDC at 85°C 0.5A 240VDC at 85°C

Notes: 1) All values unspecified are at room temperature.

2) Only typical loads are listed above. Other load specifications can be available upon request.



HONGFA RELAY

ISO9001, ISO/TS16949, ISO14001, OHSAS18001, IECQ QC 080000 CERTIFIED

2017 Rev. 1.00

ORDERING INFORMATION

Type	HF166F /	12	-1HD	L2	T	(XXX)
Coil voltage	5, 6, 12, 24, 48VDC					
Contact arrangement	1HD: 1A + 1B					
Sort	L1: 1 coil latching		L2: 2 coils latching			
Contact material	T: AgSnO ₂					
Special code ³⁾	XXX: Customer special requirement		Nil: Standard			

- Notes: 1) Flux-proofed relays can not be used in the environment with pollutants like H₂S, SO₂, NO₂, dust, etc.
 2) Water cleaning or surface process is not suggested after the flux-proofed relays are assembled on PCB.
 3) The customer special requirement express as special code after evaluating by Hongfa.

OUTLINE DIMENSIONS, WIRING DIAGRAM AND PC BOARD LAYOUT

Unit: mm

Outline Dimensions

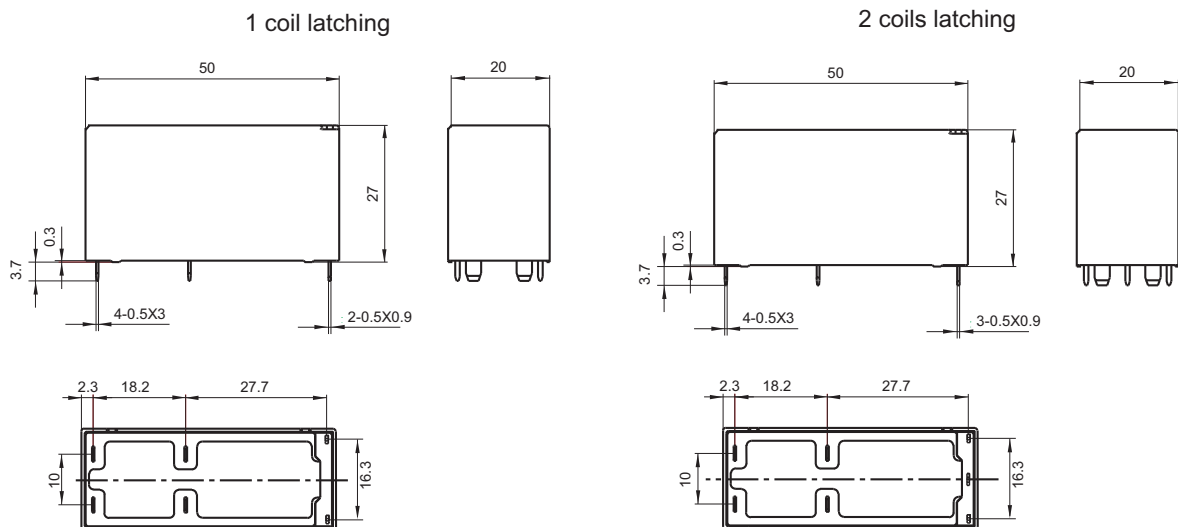

Wiring Diagram(Bottom view)



PCB Layout
(Bottom view)

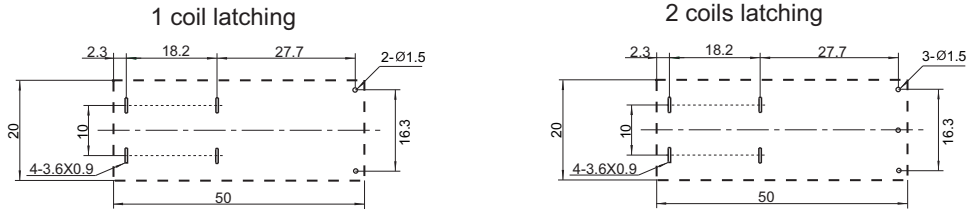

- Remark: 1) In case of no tolerance shown in outline dimension: outline dimension $\leq 1\text{mm}$, tolerance should be $\pm 0.2\text{mm}$; outline dimension $> 1\text{mm}$ and $\leq 5\text{mm}$, tolerance should be $\pm 0.3\text{mm}$; outline dimension $> 5\text{mm}$, tolerance should be $\pm 0.4\text{mm}$.
 2) The tolerance without indicating for PCB layout is always $\pm 0.1\text{mm}$.
 3) The width of the gridding is 2.52mm.

CHARACTERISTIC CURVES

SET \ RESET TIME AND VOLTAGE CURVE

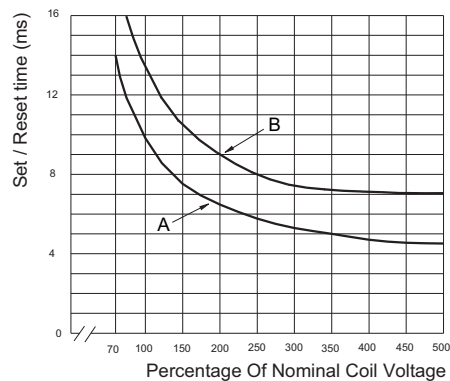

- Notes:**
 Curve B: max value
 Curve A: typical value

Notice

- Relay is on the "reset" or "set" status when being released from stock, with the consideration of shock risen from transit and relay mounting, relay would be changed to "set" or "reset" status, therefore, when application (connecting the power supply), please reset the relay to "set" or "reset" status on request.
- In order to maintain "set" or "reset" status, energized voltage to coil should reach the rated voltage, impulse width should be more than 150 ms. Do not energize voltage to "set" coil and "reset" coil simultaneously. And also long energized time (more than 1 min) should be avoided.
- Keep the product away from strong magnetic field during transportation, storage and application, to avoid change of set/reset voltage.

Disclaimer

The specification is for reference only. See to "Terminology and Guidelines" for more information. Specifications subject to change without notice. We could not evaluate all the performance and all the parameters for every possible application. Thus the user should be in a right position to choose the suitable product for their own application. If there is any query, please contact Hongfa for the technical service. However, it is the user's responsibility to determine which product should be used only.