



File No:E134517



File No:40037289



### Features

- 35A swithing capitable.
- Applicable to inverter used for photovoltaic power generation systems.
- Ideal for UPS.
- 1.8mm contact gap(compliant to European Photovoltaic Standard VDE0126).
- Product in accordance to IEC 60335 available.
- Low coil holding voltage contributes to saving energy of equipment.
- UL insulation system: class F.
- Environmental friendly product (RoHS compliant).
- Outline Dimensions: (32.2 x 27.4 x 19.4) mm.

### CONTACT DATA

Contact arrangement	1A
Voltage drop	Typ.: 15mV(at 10A) Max.: 100mV(at 10A)
Contact material	AgSnO <sub>2</sub>
Contact rating (Res. load)	Resistive: 35A 250VAC Inductive: 35A 277VAC (cosφ=0.8) 1s:9s
Max. switching voltage	277VAC
Max. switching current <sup>1)</sup>	35A
Max. switching power	9695VA
Mechanical endurance	1 x 10 <sup>6</sup> OPS
Electrical endurance	3 x 10 <sup>4</sup> OPS (35A 250VAC, Resistive load, at 85°C, 1s on 9s off)

**Notes:** 1)The relay connections and wiring have to be designed with an adequate cross sections to ensure the current flow and heat dissipation.

### CHARACTERISTICS

Insulation resistance	1000MΩ (at 500VDC)
Dielectric strength	Between coil & contacts 4000VAC 1min
	Between open contacts 2500VAC 1min
Surge voltage (between coil & contacts)	6kV (1.2/50μs)
Operate time (at nomi. volt.)	15ms max.
Release time (at nomi. volt.)	10ms max.
Temperature rise (at nomi. volt.)	70K max.(Contact load current 35A, 50% of rated voltage excitation, at 85°C)
Shock resistance	Functional 98m/s <sup>2</sup>
	Destructive 980m/s <sup>2</sup>
Vibration resistance	10Hz to 55Hz 1.5mm DA
Ambient temperature	-40°C to 85°C (Apply holding voltage to coil)
Humidity	5% to 85% RH
Termination	PCB
Unit weight	Approx.36g
Construction	Flux proofed

**Notes:** The data shown above are initial values.

### COIL

Coil power	Approx.2.25W
Holding voltage	40% to 110%U <sub>N</sub> (at 23°C) 50% to 70%U <sub>N</sub> (at 85°C)

**Notes:** 1)The coil holding voltage is the voltage applied to coil 100ms after the rated voltage.  
2)To avoid overheating and burning, the coil can not be consistently applied to with voltage larger than maximum holding voltage.

### COIL DATA

at 23°C

Nominal Voltage VDC <sup>1)</sup>	Pick-up Voltage VDC max.	Drop-out Voltage VDC min.	Max. Voltage VDC *	Coil Resistance Ω
5	3.75	0.35	5.5	11.1 x (1±10%)
12	9	0.84	13.2	64 x (1±10%)
24	18	1.68	26.4	256 x (1±10%)
48	36	3.36	52.8	1024 x (1±10%)

**Notes:** \*Maximum voltage refers to the maximum voltage which relay coil could endure in a short period of time.

### SAFETY APPROVAL RATINGS

UL/CUL	35A 277VAC/250VAC general use 3 x 10 <sup>4</sup> OPS at 85°C
VDE	35A 250VAC 3 x 10 <sup>4</sup> OPS at 85°C

**Notes:** 1) All values unspecified are at room temperature.  
2) Only typical loads are listed above. Other load specifications can be available upon request.



HONGFA RELAY

ISO9001、ISO/TS16949、ISO14001、OHSAS18001、IECQ QC 080000 CERTIFIED

2017 Rev. 1.00

## ORDERING INFORMATION

Type	HF165F /	12	-H	T	(XXX)
Coil voltage	5, 12, 24, 48VDC				
Contact arrangement	H:1 Form A				
Contact material	T: AgSnO <sub>2</sub>				
Special code <sup>3)</sup>	XXX: Customer special requirement		Nil: Standard		

Notes: 1) Water cleaning or surface process is not suggested after the flux-proofed relays are assembled on PCB.

2) Flux-proofed relays can not be used in the environment with pollutants like H<sub>2</sub>S, SO<sub>2</sub>, NO<sub>2</sub>, dust, etc.

3) The customer special requirement express as special code after evaluating by Hongfa. e.g.(335) stands for product in accordance to IEC 60335-1 (GWT).

## OUTLINE DIMENSIONS, WIRING DIAGRAM AND PC BOARD LAYOUT

Unit: mm

### Outline Dimensions

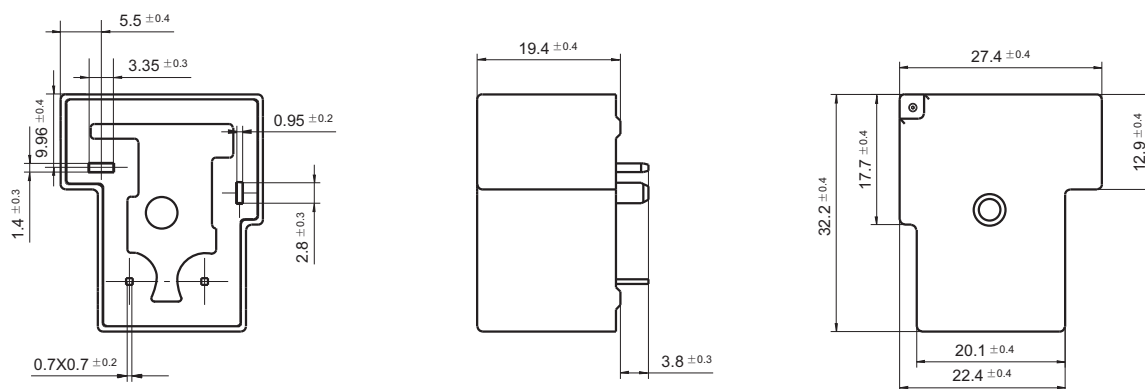

### PCB Layout (Bottom view)

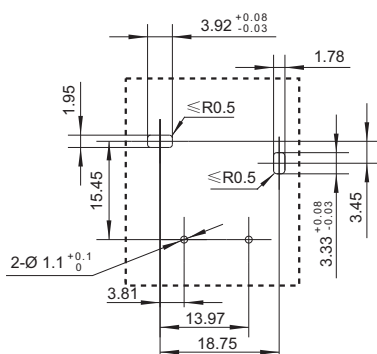

### Wiring Diagram

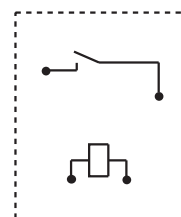

- Notes: 1) In case of no tolerance shown in outline dimension: outline dimension  $\leq 1$ mm, tolerance should be  $\pm 0.2$ mm; outline dimension  $> 1$ mm and  $\leq 5$ mm, tolerance should be  $\pm 0.3$ mm; outline dimension  $> 5$ mm, tolerance should be  $\pm 0.4$ mm.  
 2) The tolerance without indicating for PCB layout is always  $\pm 0.1$ mm.

## CHARACTERISTIC CURVES

MAXIMUM SWITCHING POWER

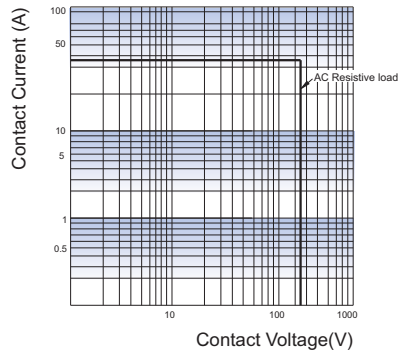

ENDURANCE CURVE

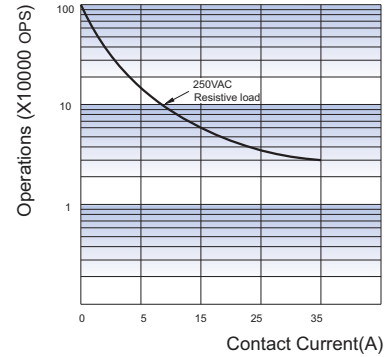

**Test conditions:**

Resistive load, 250VAC,

Flux proofed, at 85°C, 1s on 9s off

**Disclaimer**

The specification is for reference only. See to "Terminology and Guidelines" for more information. Specifications subject to change without notice. We could not evaluate all the performance and all the parameters for every possible application. Thus the user should be in a right position to choose the suitable product for their own application. If there is any query, please contact Hongfa for the technical service. However, it is the user's responsibility to determine which product should be used only.