

REVISION RECORD

REV	ECN	DESCRIPTION	DRFT	DATE

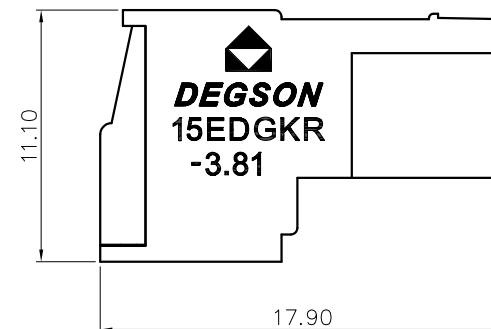

15EDGKRP - 3.81 - XXP - 1Y - 00A (H)  
 (Series No.) (Pitch) (Poles) (Color) 1.(Grey)2.(Blue)3.(Black)4.(Green)5.(Orange)  
 6.(Red)7.(Transparent)8.(Yellow)9.(White)  
 00A-(Standard) (RoHS)  
 (Single Pitch)

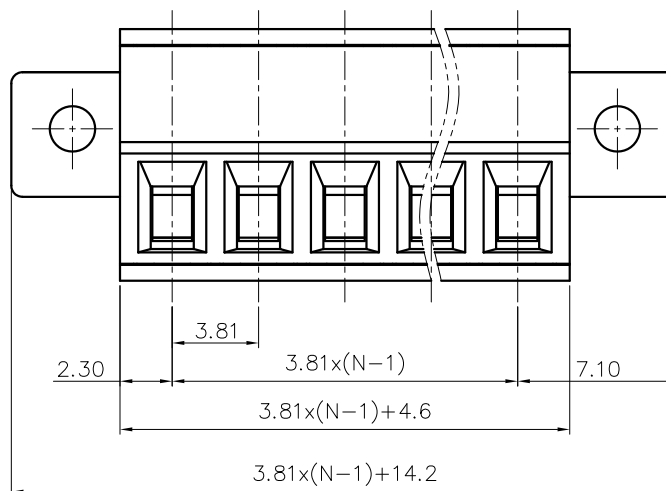
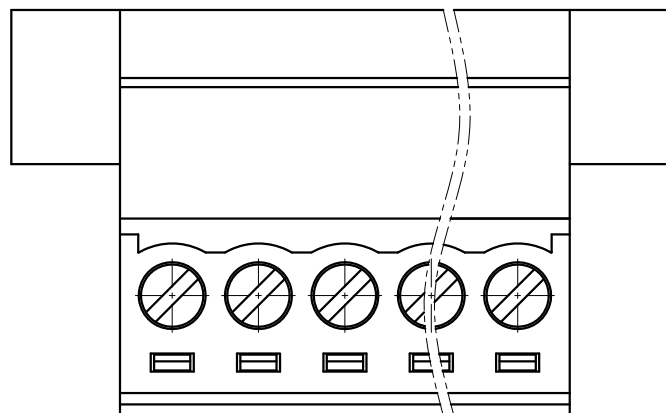
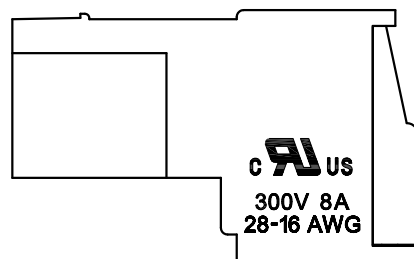

NOTES1:

UL Standard

- 1.Rated voltage/current : 300V / 8A
- 2.Withstanding voltage : AC1600V/1Min.
- 3.Torque value : M2 , 1.77Lb.in
- 4.Wire range : 28~16AWG

IEC Standard

1. Pollution degree	2
Overvoltage category	II
Rate impulse voltage(KV)	2.5KV
Rate voltage(V)	250V
Rate current(A)	7A

- 2.Torque value : M2 , 0.2N·m
- 3.Wire range : 1.5mm<sup>2</sup>

NOTES2:

- 1.Dimension shall be interpreted per ASME Y14.5-2009
- 2.Pitch : 3.81mm, Poles : N=02~16P
- 3.Stripping length : 6~7mm
- 4.Operating temperature: -40°C~+105°C
- 5.Undimensioned tolerances:

Pitch range in mm		Nominal dimension range in mm							±	∠	∇
TO	Over	TO	Over	TO	Over	TO	Over	TO	Over	TO	
6	10	6	10	10	15	15	20	20	25	25	
±0.15	±0.20	±0.30	±0.30	±0.50	±0.70	±1.00	±1.30	±2'			

6.RoHS Compliance

DETACHED LISTS	PART NO.:	NINGBO DEGSON ELECTRICAL CO., LTD			
	APPD:	NAME: 15EDGKRP-3.81-XXP-1Y-00A(H)			
	CHKD:	TITLE: CUSTOMER DRAWING			
	DRFT:	DRAWING NO.:		REV	DO
THIRD ANGLE PROJECTION		DO NOT SCALE DRAWING		SHEET	1/1
		MM (INCH)	SCALE	1:1	