

REVISION RECORD			
REV	ECN	DESCRIPTION	DRFT DATE

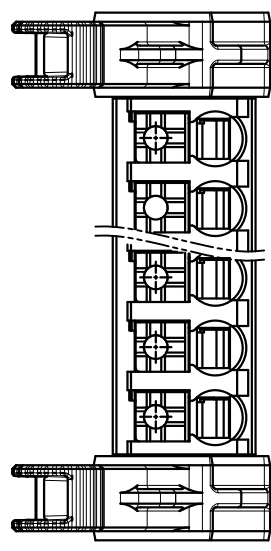

15EDGKNGB - 3.81 - XXP - 1Y - 1000A (H)
 (Series No.) (Pitch) (Poles) (Single Pitch) (Color): 1.(Grey)
 2.(Blue)
 3.(Black)
 4.(Green)
 5.(Orange)
 6.(Red)
 7.(Transparent)
 8.(Yellow)
 9.(White)

NOTES1:

- UL Standard
- 1.Rated voltage/current : 300V / 8A
- 2.Withstanding voltage : AC1600V/1Min.
- 3.Wire range : 26~16AWG

IEC Standard

1. Pollution degree	2
Overvoltage category	II
Rate impulse voltage(KV)	2.5KV
Rate voltage(V)	320V
Rate current(A)	17.5A

2. Wire range : 0.2~1.5mm²

NOTES2:

- 1.Dimension shall be interpreted per ASME Y14.5-2009
- 2.Pitch : 3.81mm, Poles : N=02~20P
- 3.Stripping length : 9~10mm
- 4.Operating temperature : -40°C~+105°C
- 5.Undimensioned tolerances:

Pitch range in mm	Nominal dimension	range in mm	Over	Over	Over	Over
TO	TO	TO	TO	TO	TO	TO
6	10	30	60	100	150	0.1/10
±0.15	±0.20	±0.30	±0.50	±0.70	±1.00	±2°

6.RoHS Compliance

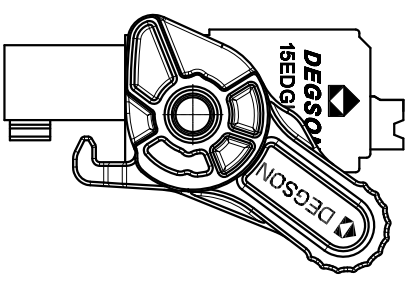
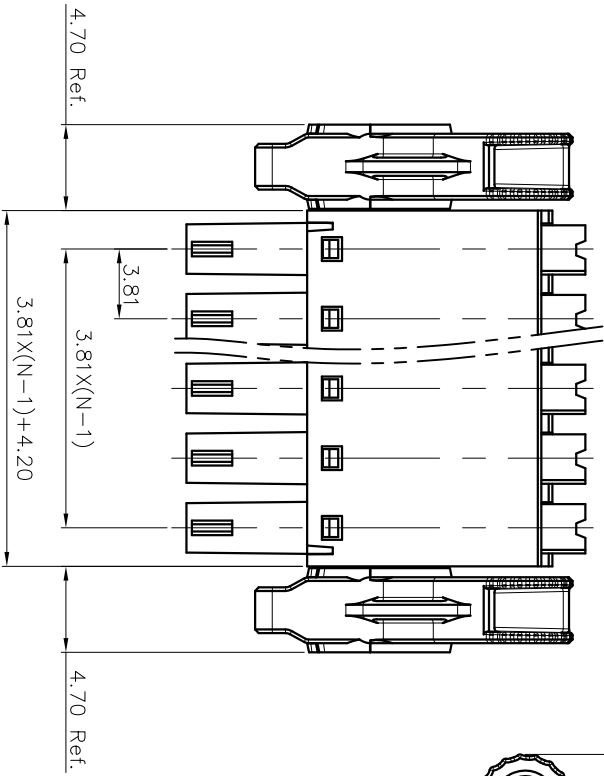
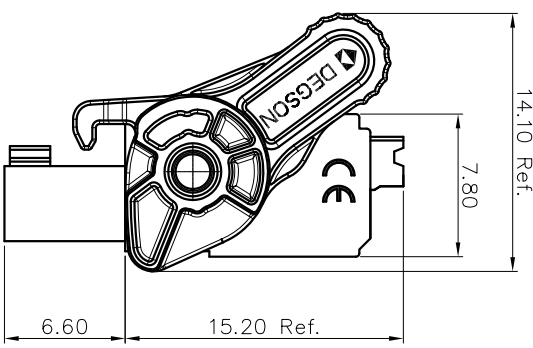

DETACHED LISTS	
PART NO.:	/
APPD:	/
CHKD:	/
DRFT:	/
THIRD ANGLE PROJECTION	

NAME:	DEGSON 宁波高松电子有限公司
NAME:	NINGBO DEGSON ELECTRICAL CO., LTD
TITLE:	CUSTOMER DRAWING
DRAWING NO.:	/
DO NOT SCALE DRAWING	

15EDGKNGB-3.81-XXP-1Y-1000A(H)