

REVISION RECORD				
REV	ECN	DESCRIPTION	DRFT	DATE

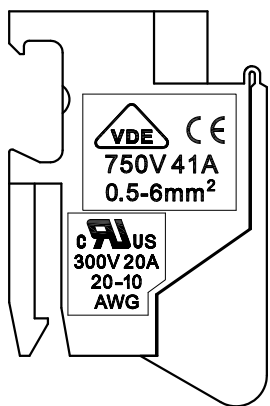
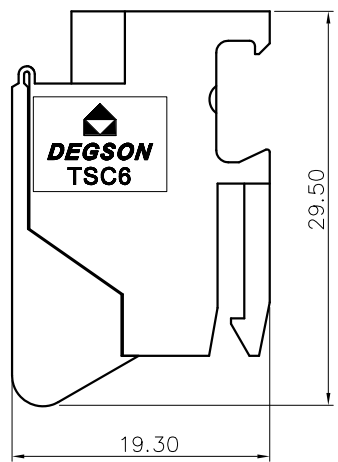
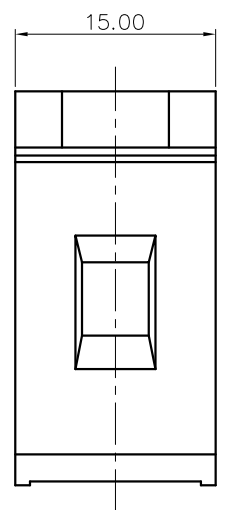
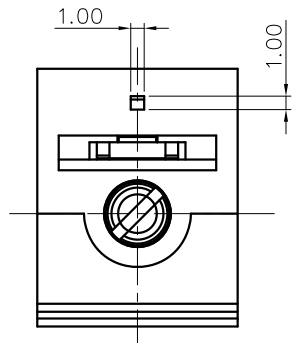

NOTES1:
 UL Standard
 1.Rated Voltage/Current : 300V / 20A
 2.Torque Value : M4 , 10.53Lb.in
 3.Wire Range : 20~10AWG
 IEC Standard
 1.Rated Voltage/Current : 750V / 41A
 2.Torque Value : M4 , 1.2N·m
 3.Wire Range : 0.5~6mm²

NOTES2:
 1.Dimension shall be interpreted per ASME Y14.5-2009
 2.Poles : N=01P
 3.Stripping length : 10~12mm
 4.Withstanding Voltage : AC3000V/1Min.
 5.Operating temperature: -40°C~+105°C
 6.Undimensioned Tolerances:

Pitch range in mm		Nominal dimension range in mm					-	∩	∇
TO	Over	Over	TO	Over	Over	Over	0.1/10		
6	6	10	30	30	60	100			
10	10	24	30	60	100	150			
	±0.15	±0.20	±0.30	±0.30	±0.50	±0.70	±1.00	±1.30	±2*

7.RoHS Compliance

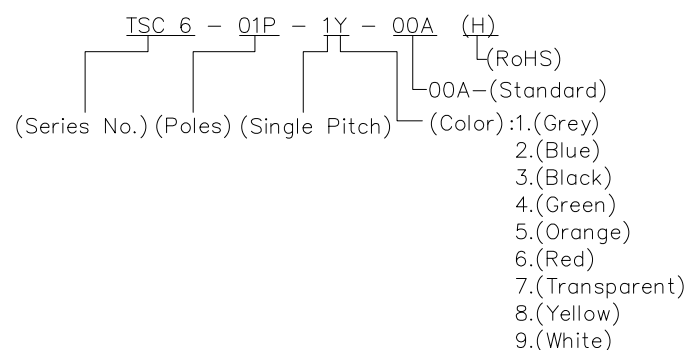

DETACHED LISTS	PART NO.:	NINGBO DEGSON ELECTRICAL CO., LTD			
	APPD:	NAME: TSC 6-01P-1Y-00A(H)			
	CHKD:	TITLE: CUSTOMER DRAWING			
	DRFT:	DRAWING NO.:		REV	DO
 THIRD ANGLE PROJECTION		MM (INCH)	DO NOT SCALE DRAWING	SHEET	1/1
			SCALE	1:1	