

REVISION RECORD				
REV	ECN	DESCRIPTION	DRFT	DATE

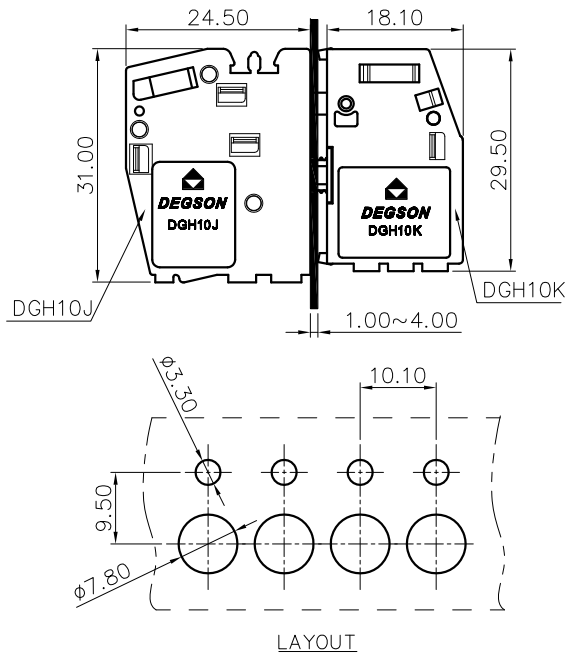

DGH10J-01P-1Y-00A(H)

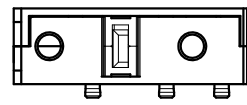
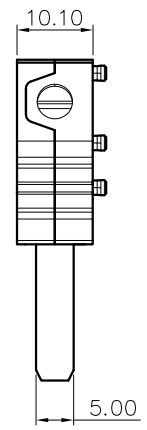
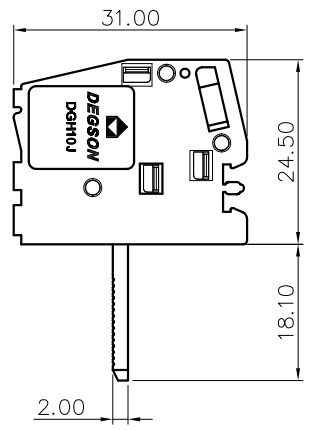
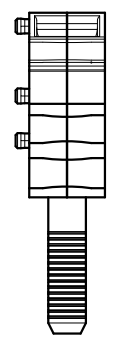
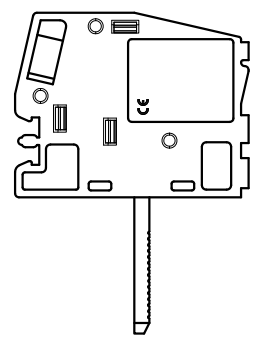

NOTES1:

UL Standard

- 1.Rated voltage/current : 300V / 65A
- 2.Withstanding voltage : AC1600V/1Min.
- 3.Torque value : M4 , 10.53Lb.in
- 4.Wire range : 24~6AWG

IEC Standard

1. Pollution degree	3
Overvoltage category	III
Rate impulse voltage(KV)	8.0KV
Rate voltage(V)	500 V
Rate current(A)	76 A

- 2.Torque value : M4 , 1.2N·m
- 3.Wire range : 0.5~16mm²

NOTES2:

- 1.Dimension shall be interpreted per ASME Y14.5-2009
- 2.Pitch : 10.10mm, Poles : N=01P
- 3.Stripping length : 10mm
- 4.Operating temperature:-40°C~+105°C
- 5.Undimensioned tolerances:

Pitch range in mm		Nominal dimension range in mm				-	∧	□
TO	Over	Over	Over	Over	Over	0.1/10		
6	10	10	30	60	100	∠		
±0.15	±0.20	±0.30	±0.30	±0.50	±0.70	±1.00	±1.30	±2*

- 6.RoHS Compliance

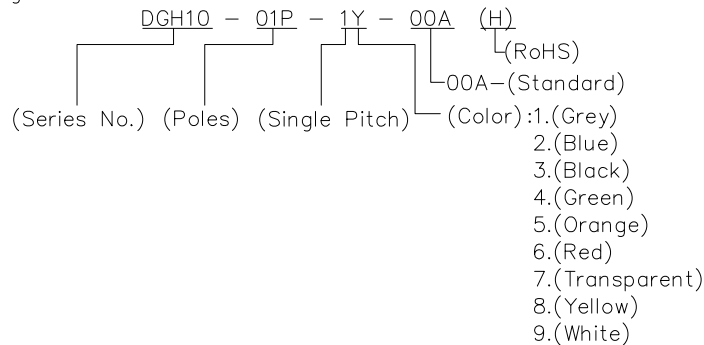

DGH10K-01P-1Y-00A(H)

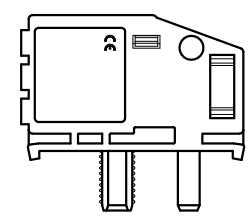
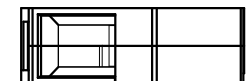
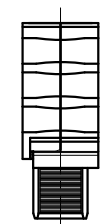
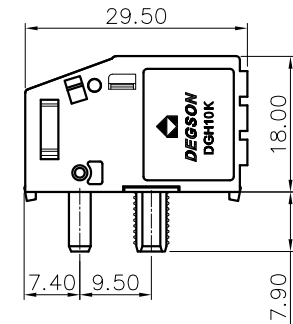
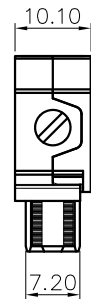

DETACHED LISTS	PART NO.:	/			
	APPD:	/			
	CHKD:	/			
	DRFT:	/			
	THIRD ANGLE PROJECTION		DRAWING NO.:		/
		MM (INCH)		DO NOT SCALE DRAWING	
		NAME:		NINGBO DEGSON ELECTRICAL CO., LTD	
		TITLE:		CUSTOMER DRAWING	
		REV		D0	
		SHEET		1/1	
		SCALE		1:1	