

REVISION RECORD				
REV	ECN	DESCRIPTION	DRFT	DATE

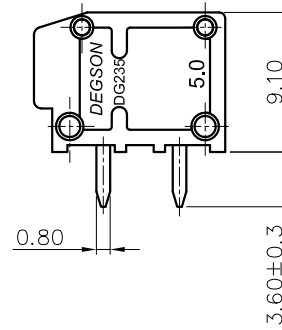
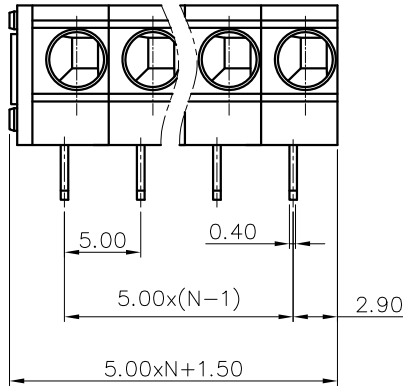
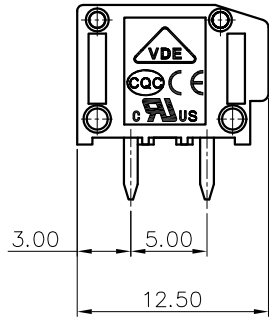
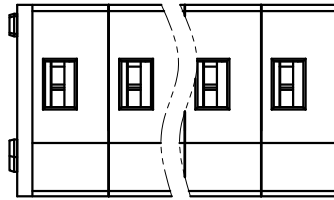

NOTES1:

UL Standard

- 1. Rated voltage/current : 300V / 5A
- 2. Wire range : 20~18AWG

IEC Standard

- 1. Rated voltage/current : 250V / 15A
- 2. Wire range : 0.2~1.5mm²(STR)
0.2~2.5mm²(SOL)

NOTES2:

- 1. Dimension shall be interpreted per ASME Y14.5-2009
- 2. Pitch : 5.00mm, Poles : N=01~XXP
- 3. Stripping length : 9~10mm
- 4. Withstanding voltage : AC2000V/1Min.
- 5. Operating temperature: -40°C~+105°C
- 6. Undimensioned tolerances:

Pitch range in mm		Nominal dimension range in mm					—	∩	∠
TO	Over	TO	Over	TO	Over	TO	Over	TO	
6	10	6	10	30	60	100	150	0.1/10	
±0.15	±0.20	±0.30	±0.30	±0.50	±0.70	±1.00	±1.30	<	

7. RoHS Compliance

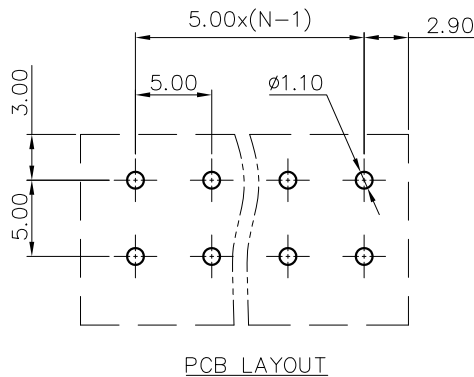
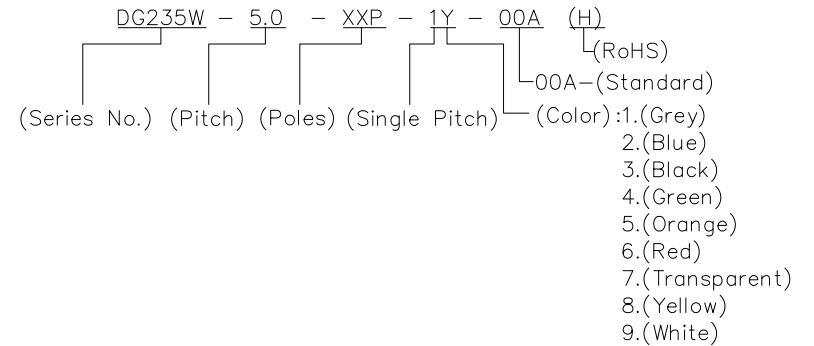

DETACHED LISTS	PART NO.:	NINGBO DEGSON ELECTRICAL CO., LTD			
	APPD:	NAME: DG235W-5.0-XXP-1Y-00A(H)			
	CHKD:	TITLE: CUSTOMER DRAWING			
	DRFT:	DRAWING NO.:		REV	DO
THIRD ANGLE PROJECTION		MM (INCH)	DO NOT SCALE DRAWING	SHEET 1/1	SCALE 1:1