

REVISION RECORD				
REV	ECN	DESCRIPTION	DRFT	DATE

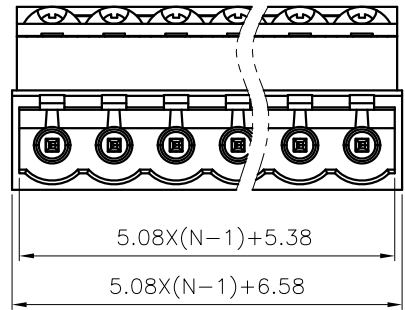
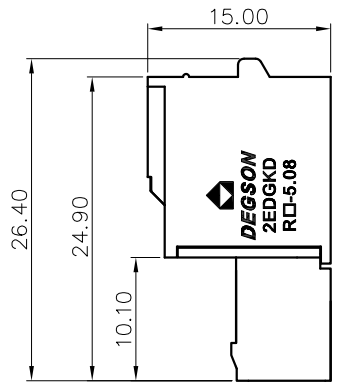
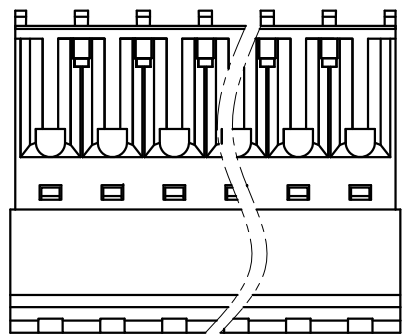
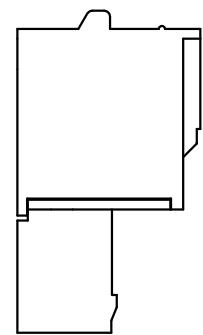
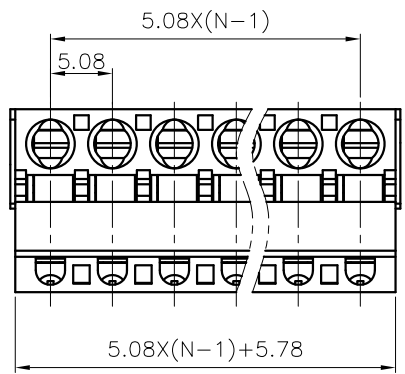

NOTES1:

- UL Standard
 1. Rated Voltage/Current : 300V / 10A
 2. Withstanding Voltage : AC1600V/1Min.
 3. Wire Range : 26~12AWG

IEC Standard

1. Pollution Degree	2
Overvoltage Category	III
Rate Impulse Voltage(KV)	4.0KV
Rate Voltage(V)	320V
Rate Current(A)	20A

2. Wire Range : 0.2~2.5mm²

NOTES2:

1. Dimension shall be interpreted per ASME Y14.5-2009
 2. Pitch : 5.08mm, Poles : N=02~18P
 3. Stripping length : 9~10mm
 4. Operating temperature : -40°C~+105°C
 5. Undimensioned Tolerances:

Pitch range in mm	Nominal dimension range in mm						0.1/10	
	TO 6	Over 6 TO 10	Over 10 TO 24	TO 30	Over 30 TO 60	Over 60 TO 100		Over 100 TO 150
±0.15	±0.20	±0.30	±0.30	±0.50	±0.70	±1.00	±1.30	±2*

6. RoHS Compliance

2EDGKDRW - 5.08 - XXP - 1Y - 00A (H)
 (Series No.) (Pitch) (Poles) (Single Pitch) (Color):1.(Grey)
 2.(Blue)
 3.(Black)
 4.(Green)
 5.(Orange)
 6.(Red)
 7.(Transparent)
 8.(Yellow)
 9.(White)

DETACHED LISTS	PART NO.:	/			宁波高松电子有限公司 NINGBO DEGSON ELECTRICAL CO., LTD	
	APPD:	/	NAME: 2EDGKDRW-5.08-XXP-1Y-00A(H)			
	CHKD:	/				
	DRFT:	/	TITLE: CUSTOMER DRAWING		REV	DO
	THIRD ANGLE PROJECTION		DRAWING NO.: /		SHEET	1/1
		MM (INCH) DO NOT SCALE DRAWING		SCALE	1:1	