

REVISION RECORD				
REV	ECN	DESCRIPTION	DRFT	DATE

NOTES1:

UL Standard

1. Rated voltage/current : 300V / 15A
2. Withstanding voltage : AC1600V/1Min.
3. Torque value : M3 , 4.43Lb.in
4. Wire range : 28~12AWG

IEC Standard

1. Pollution degree	2	2	3
Overvoltage category	II	III	III
Rate impulse voltage(KV)	4.0K	4.0KV	4.0KV
Rate voltage(V)	630V	320V	250V
Rate current(A)	12A		

2. Torque value : M3 , 0.5N·m
3. Wire range : 0.2~2.5mm<sup>2</sup>

NOTES2:

1. Dimension shall be interpreted per ASME Y14.5-2009
2. Pitch : 5.08mm, Poles : N=02P~24P
3. Stripping length : 7~8mm
4. Operating temperature: -40°C~+105°C
5. Undimensioned tolerances:

Pitch range in mm		Nominal dimension range in mm				0.1/10	
TO	Over	Over	Over	Over			
6	10	10	30	60	100	±2'	
10	24	30	60	100	150		
±0.15		±0.20	±0.30	±0.30	±0.50	±1.00	±1.30

6. RoHS Compliance

H  
G  
F  
E  
D  
C  
B  
A

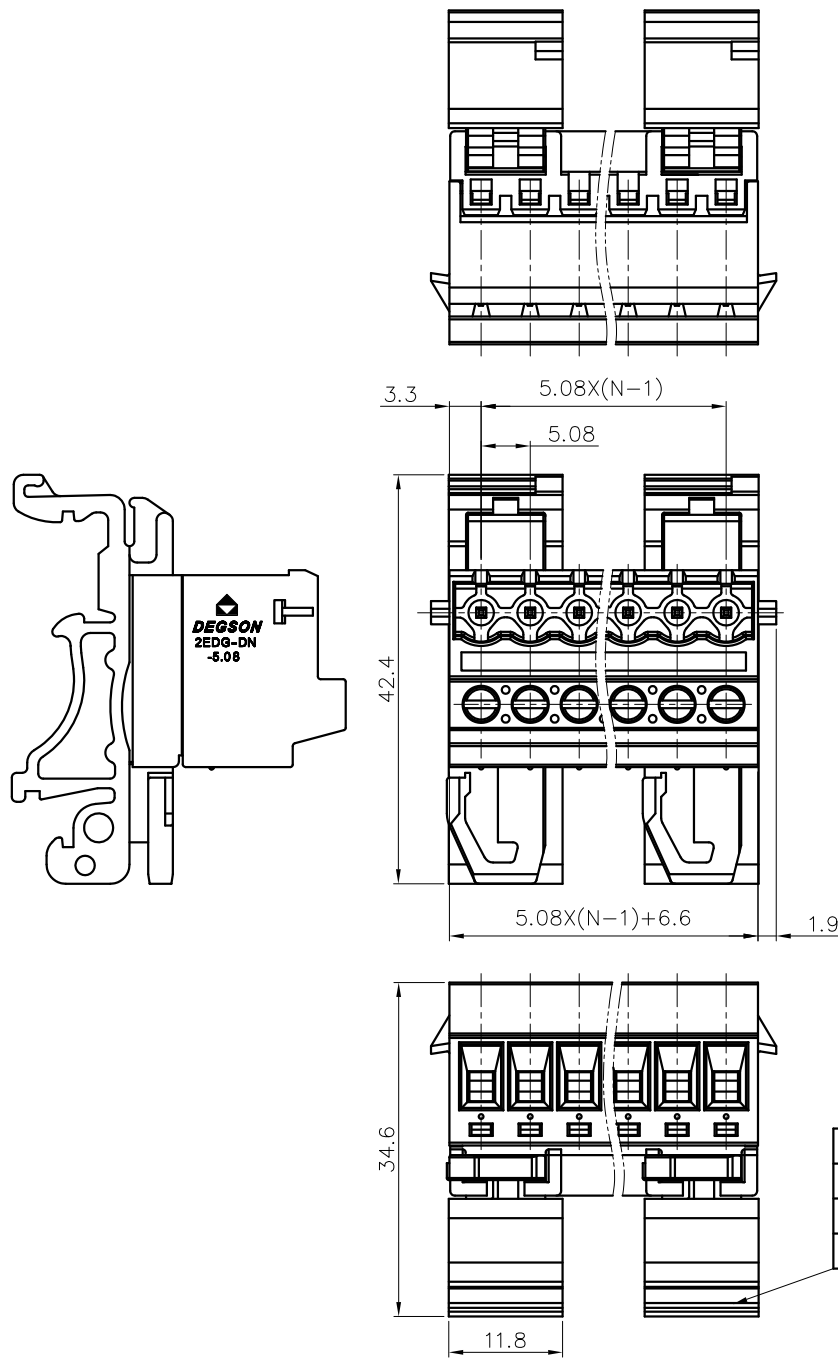

2EDG - UDBN - 5.08 - XXP - 1Y - 00A (H)  
 (Series No.) (Pitch) (Poles) (Single Pitch) (Color): 1.(Grey)  
 2.(Blue)  
 3.(Black)  
 4.(Green)  
 5.(Orange)  
 6.(Red)  
 7.(Transparent)  
 8.(Yellow)  
 9.(White)

DETACHED LISTS	PART NO.:	/		
	APPD:	/		
	CHKD:	/		
	DRFT:	/		
	THIRD ANGLE PROJECTION		/	
DRAWING NO.:		/		
DO NOT SCALE DRAWING		MM (INCH)	SCALE	1:1
NAME:		NINGBO DEGSON ELECTRICAL CO., LTD		
TITLE:		CUSTOMER DRAWING		
REV		DO		
SHEET		1/1		

H  
G  
F  
E  
D  
C  
B  
A