

REVISION RECORD

REV	ECN	DESCRIPTION	DRFT	DATE
-----	-----	-------------	------	------

NOTES1:

UL Standard

1. Rated voltage/current : 600V / 52A
2. Withstanding voltage : AC2200V/1Min.
3. Torque value : M4 , 10.53Lb.in
4. Wire range : 20~6AWG

IEC Standard

1. Pollution Degree	3
Overvoltage Category	III
Rate Impulse Voltage(KV)	6.0KV
Rate Voltage(V)	600V
Rate Current(A)	57A

2. Torque value : M4 , 1.20N·m
3. Wire range : 0.5~10mm²

NOTES2:

1. Dimension shall be interpreted per ASME Y14.5-2009
2. Pitch : 10.16mm, Poles : N=02~08P
3. Stripping length : 7-8mm
4. Operating temperature: -40°C~+105°C
5. Undimensioned tolerances:

Pitch range in mm		Nominal dimension range in mm				0.1/10		
To 6	Over 6 To 10	Over 10 To 24	To 30	Over 30 To 60	Over 60 To 100		Over 100 To 150	Over 150
±0.15	±0.20	±0.30	±0.30	±0.50	±0.70	±1.00	±1.30	±2*

6. RoHS Compliance

5EDGK - 10.16 - XXP - 1Y - 00A (H)

(Series No.) (Pitch) (Poles) (Single Pitch) (Color): 1.(Grey)
 2.(Blue)
 3.(Black)
 4.(Green)
 5.(Orange)
 6.(Red)
 7.(Transparent)
 8.(Yellow)
 9.(White)

(RoHS)
 00A-(Standard)

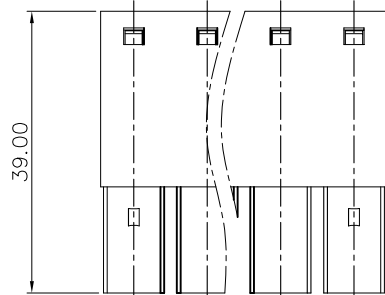
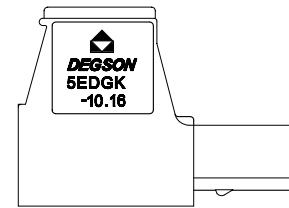
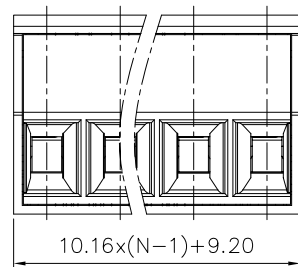
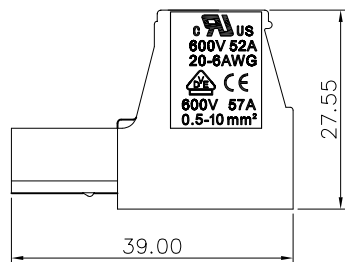
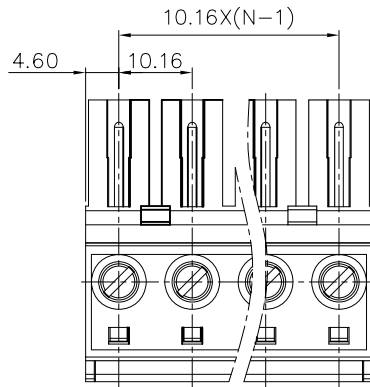

DETACHED LISTS	PART NO.: /	宁波高松电子有限公司 NINGBO DEGSON ELECTRICAL CO., LTD		
	APPD: /	NAME: 5EDGK-10.16-XXP-1Y-00A(H)		
	CHKD: /	TITLE: CUSTOMER DRAWING		REV: /
	DRFT: /	DRAWING NO.: /		DO: /
THIRD ANGLE PROJECTION		DRAWING NO.: / MM (INCH)	SHEET: 1/1	SCALE: 1:1