

REVISION RECORD

REV	ECN	DESCRIPTION	DRFT	DATE
-----	-----	-------------	------	------

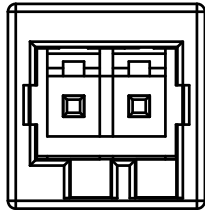

02P

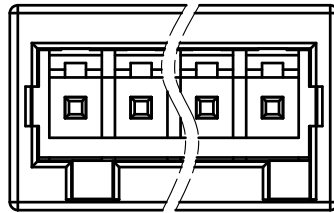

NOTES1:

UL Standard

1. Rated voltage/current : 150V / 4A
2. Withstanding voltage : AC1300V/1Min.

IEC Standard

1. Pollution Degree	3
Overvoltage Category	III
Rate Impulse Voltage(KV)	2.5KV
Rate Voltage(V)	130V
Rate Current(A)	6A

NOTES2:

1. Dimension shall be interpreted per ASME Y14.5-2009
2. Pitch : 2.50mm, Poles : N=02~12P
3. Operating temperature: -40°C~+105°C
4. Undimensioned tolerances:

Pitch range in mm	Nominal dimension range in mm						0.1/10	
	Over 6 TO 10	Over 10 TO 24	Over 30 TO 60	Over 60 TO 100	Over 100 TO 150	Over 150		
±0.15	±0.20	±0.30	±0.30	±0.50	±0.70	±1.00	±1.30	±2'

5. RoHS Compliance

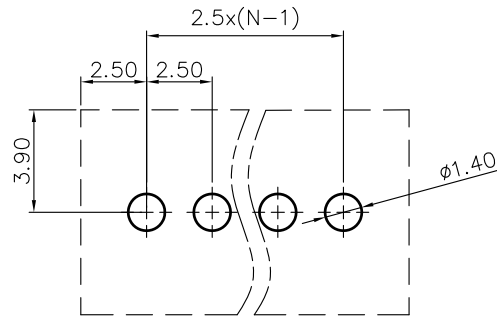
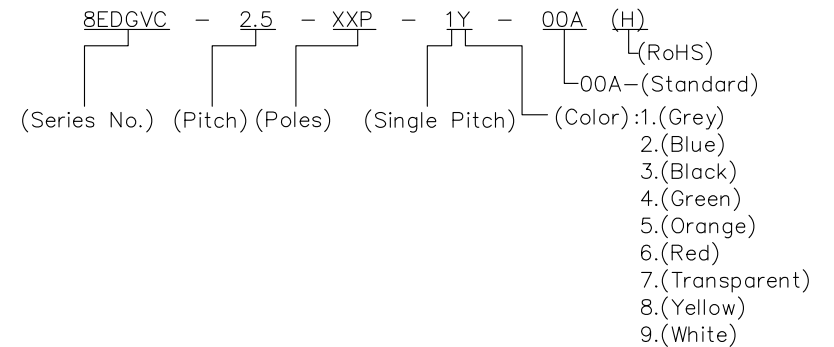
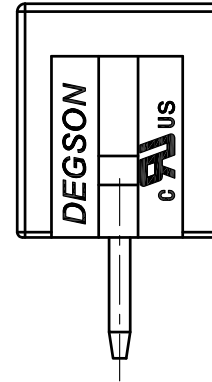
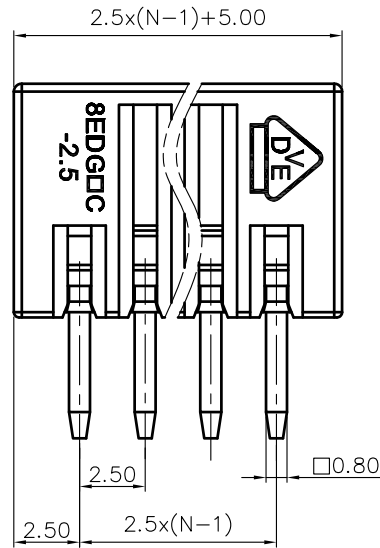
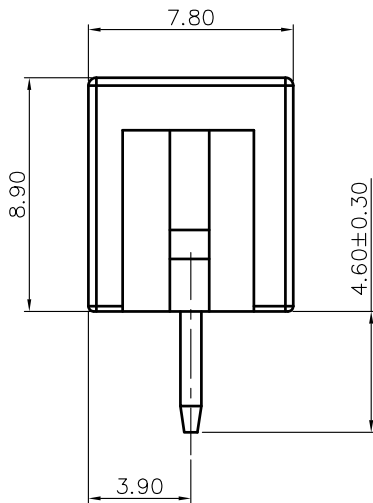

PCB LAYOUT

DETACHED LISTS	PART NO.:	/			
	APPD:	/			
	CHKD:	/			
	DRFT:	/			
	<p>THIRD ANGLE PROJECTION</p>		<p>DO NOT SCALE DRAWING</p>		
<p>宁波高松电子有限公司 NINGBO DEGSON ELECTRICAL CO., LTD</p>		<p>NAME: 8EDGVC-2.5-XXP-1Y-00A(H)</p>			
TITLE: CUSTOMER DRAWING		REV	DO		
DRAWING NO.:		/		SHEET	
MM (INCH)		SCALE		1/1	
		SCALE		1:1	