

REVISION RECORD				
REV	ECN	DESCRIPTION	DRFT	DATE

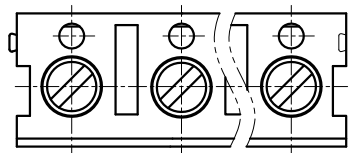

NOTES1:  
 UL Standard  
 1.Rated voltage/current : 300V / 15A  
 2.Torque value : M2.5 , 2.58Lb.in  
 3.Wire range : 22~14AWG  
 IEC Standard  
 1.Rated voltage/current : 450V / 20A  
 2.Torque value : M2.5 , 0.29N·m  
 3.Wire range : 1.0~2.5mm<sup>2</sup>

NOTES2:  
 1.Dimension shall be interpreted per ASME Y14.5-2009  
 2.Pitch : 7.5mm, Poles : N=2~XXP  
 3.Stripping length : 6~7mm  
 4.Withstanding voltage : AC2500V/1Min  
 5.Operating temperature: -30°C~+120°C  
 6.Undimensioned tolerances:

Pitch range in mm		Nominal dimension range in mm					-	∩	∇
TO	Over	TO	Over	TO	Over	TO	TO	TO	
6	6	10	10	30	60	100	150	0.1/10	
6	10	24	30	60	100	150	1.30	<	
±0.15	±0.20	±0.30	±0.30	±0.50	±0.70	±1.00	±1.30	±2'	

7.RoHS Compliance

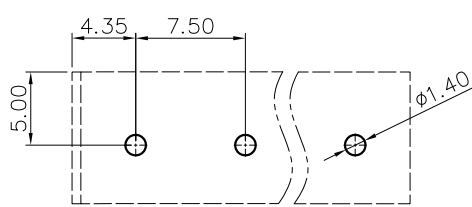
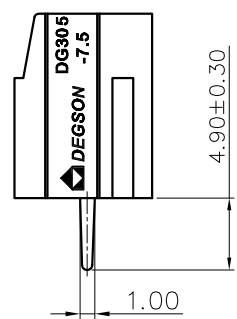
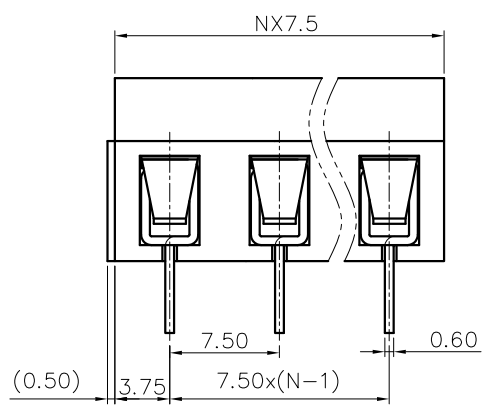
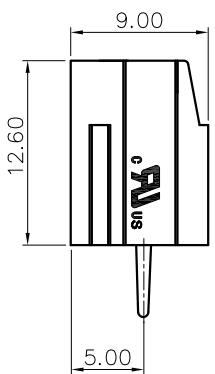
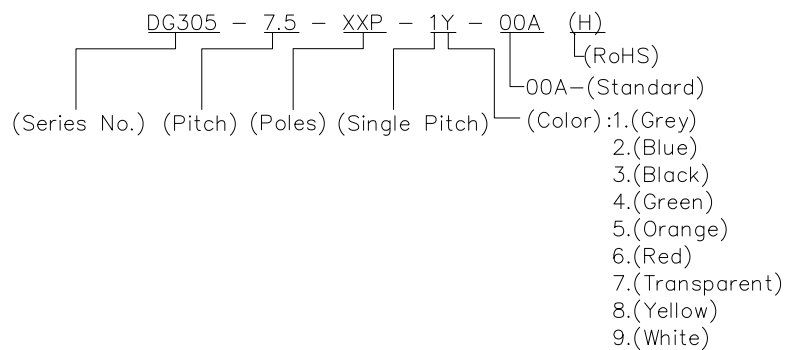

PCB LAYOUT

DETACHED LISTS	PART NO.:	NINGBO DEGSON ELECTRICAL CO., LTD			
	APPD:	NAME: DG305-7.5-XXP-1Y-00A(H)			
	CHKD:	TITLE: CUSTOMER DRAWING			
	DRFT:	DRAWING NO.:		REV	DO
THIRD ANGLE PROJECTION		MM (INCH)	DO NOT SCALE DRAWING	SHEET 1/1	SCALE 1:1