



复旦微电子

# ***FM24C02A*** ***2-Wire Serial EEPROM***

**Data Sheet**

---

**May. 2012**

INFORMATION IN THIS DOCUMENT IS INTENDED AS A REFERENCE TO ASSIST OUR CUSTOMERS IN THE SELECTION OF SHANGHAI FUDAN MICROELECTRONICS GROUP CO., LTD PRODUCT BEST SUITED TO THE CUSTOMER'S APPLICATION; THEY DO NOT CONVEY ANY LICENSE UNDER ANY INTELLECTUAL PROPERTY RIGHTS, OR ANY OTHER RIGHTS, BELONGING TO SHANGHAI FUDAN MICROELECTRONICS GROUP CO., LTD OR A THIRD PARTY.

WHEN USING THE INFORMATION CONTAINED IN THIS DOCUMENTS, PLEASE BE SURE TO EVALUATE ALL INFORMATION AS A TOTAL SYSTEM BEFORE MAKING A FINAL DECISION ON THE APPLICABILITY OF THE INFORMATION AND PRODUCTS. PURCHASERS ARE SOLELY RESPONSIBLE FOR THE CHOICE, SELECTION AND USE OF THE SHANGHAI FUDAN MICROELECTRONICS GROUP CO., LTD PRODUCTS AND SERVICES DESCRIBED HEREIN, AND SHANGHAI FUDAN MICROELECTRONICS GROUP CO., LTD ASSUMES NO LIABILITY WHATSOEVER RELATING TO THE CHOICE, SELECTION OR USE OF THE SHANGHAI FUDAN MICROELECTRONICS GROUP CO., LTD PRODUCTS AND SERVICES DESCRIBED HEREIN. UNLESS EXPRESSLY APPROVED IN WRITING BY AN AUTHORIZED SHANGHAI FUDAN MICROELECTRONICS GROUP CO., LTD REPRESENTATIVE, SHANGHAI FUDAN MICROELECTRONICS GROUP CO., LTD PRODUCTS ARE NOT RECOMMENDED, AUTHORIZED OR WARRANTED FOR USE IN MILITARY, AIR CRAFT, SPACE, LIFE SAVING, OR LIFE SUSTAINING APPLICATIONS, NOR IN PRODUCTS OR SYSTEMS WHERE FAILURE OR MALFUNCTION MAY RESULT IN PERSONAL INJURY, DEATH, OR SEVERE PROPERTY OR ENVIRONMENTAL DAMAGE.

FUTURE ROUTINE REVISIONS WILL OCCUR WHEN APPROPRIATE, WITHOUT NOTICE. CONTACT SHANGHAI FUDAN MICROELECTRONICS GROUP CO., LTD SALES OFFICE TO OBTAIN THE LATEST SPECIFICATIONS AND BEFORE PLACING YOUR PRODUCT ORDER. PLEASE ALSO PAY ATTENTION TO INFORMATION PUBLISHED BY SHANGHAI FUDAN MICROELECTRONICS GROUP CO., LTD BY VARIOUS MEANS, INCLUDING SHANGHAI FUDAN MICROELECTRONICS GROUP CO., LTD HOME PAGE ([HTTP://WWW.FMSH.COM](http://www.fms.com)).

PLEASE CONTACT SHANGHAI FUDAN MICROELECTRONICS GROUP CO., LTD LOCAL SALES OFFICE FOR THE SPECIFICATION REGARDING THE INFORMATION IN THIS DOCUMENT OR SHANGHAI FUDAN MICROELECTRONICS GROUP CO., LTD PRODUCTS.

#### Trademarks

Shanghai Fudan Microelectronics Group Co., Ltd name and logo, the “复旦” logo are trademarks or registered trademarks of Shanghai Fudan Microelectronics Group Co., Ltd or its subsidiaries in China.

Shanghai Fudan Microelectronics Group Co., Ltd, Printed in the China, All Rights Reserved.

## Description

The FM24C02A provides low operation voltage of 2048 bits of serial electrically erasable and programmable read-only memory (EEPROM) organized as 256 words of 8 bits each. The device is optimized for use in many industrial and commercial applications where low-power and low-voltage operations are essential.

## Features

- **Low Operation Voltage:**  $V_{CC} = 1.7V$  to  $5.5V$
- **Internally Organized:**  $256 \times 8$
- **Two-wire Serial Interface**
- **Schmitt Trigger, Filtered Inputs for Noise Suppression**
- **Bi-directional Data Transfer Protocol**
- **1MHz (2.5V~5.5V) and 400 kHz (1.7V) Compatibility**
- **Write Protect Pin for Hardware Data Protection**
- **8-byte Page Write Modes**
- **Partial Page Writes are Allowed**
- **Self-timed Write Cycle (5 ms max)**
- **High-reliability**
  - **Endurance:** 1,000,000 Write Cycles
  - **Data Retention:** 100 Years
- **PDIP8, SOP8, TSSOP8 Packages (RoHS Compliant and Halogen-free)**

## Absolute Maximum Ratings

Operating Temperature (Plastic Package)	-55°C to +125°C
Operating Temperature (Module Package)	-20°C to +60°C
Storage Temperature (Plastic Package)	-65°C to +150°C
Storage Temperature (Module Package)	-25°C to +70°C
Voltage on Any Pin with Respect to Ground	-1.0V to +7.0V
Maximum Operating Voltage	6.25V
DC Output Current	5.0 mA

\*NOTICE: Stresses beyond those listed under “Absolute Maximum Ratings” may cause permanent damage to the device. This is a stress rating only and functional operation of the device at these or any other conditions beyond those indicated in the operational sections of this specification are not implied. Exposure to absolute maximum rating conditions for extended periods may affect device reliability.

## Packaging Type

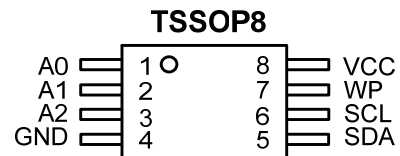
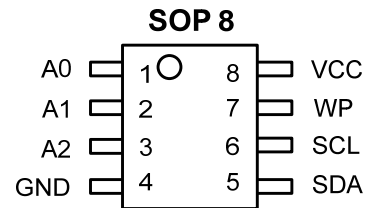
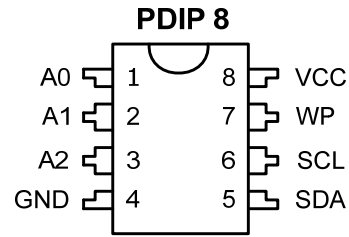

### Module package (8 Pin)

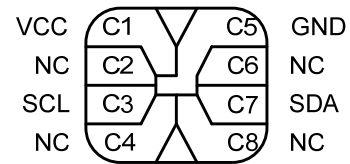

### Module package (6 Pin)

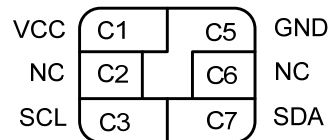

## Pin Configurations

Pin Name	Function
A0~A2	Not Connect
NC	Not Connect
SDA	Serial Data Input/Output
SCL	Serial Clock Input
WP	Write Protect
$V_{CC}$	Power Supply
GND	Ground

Figure 1. Block Diagram

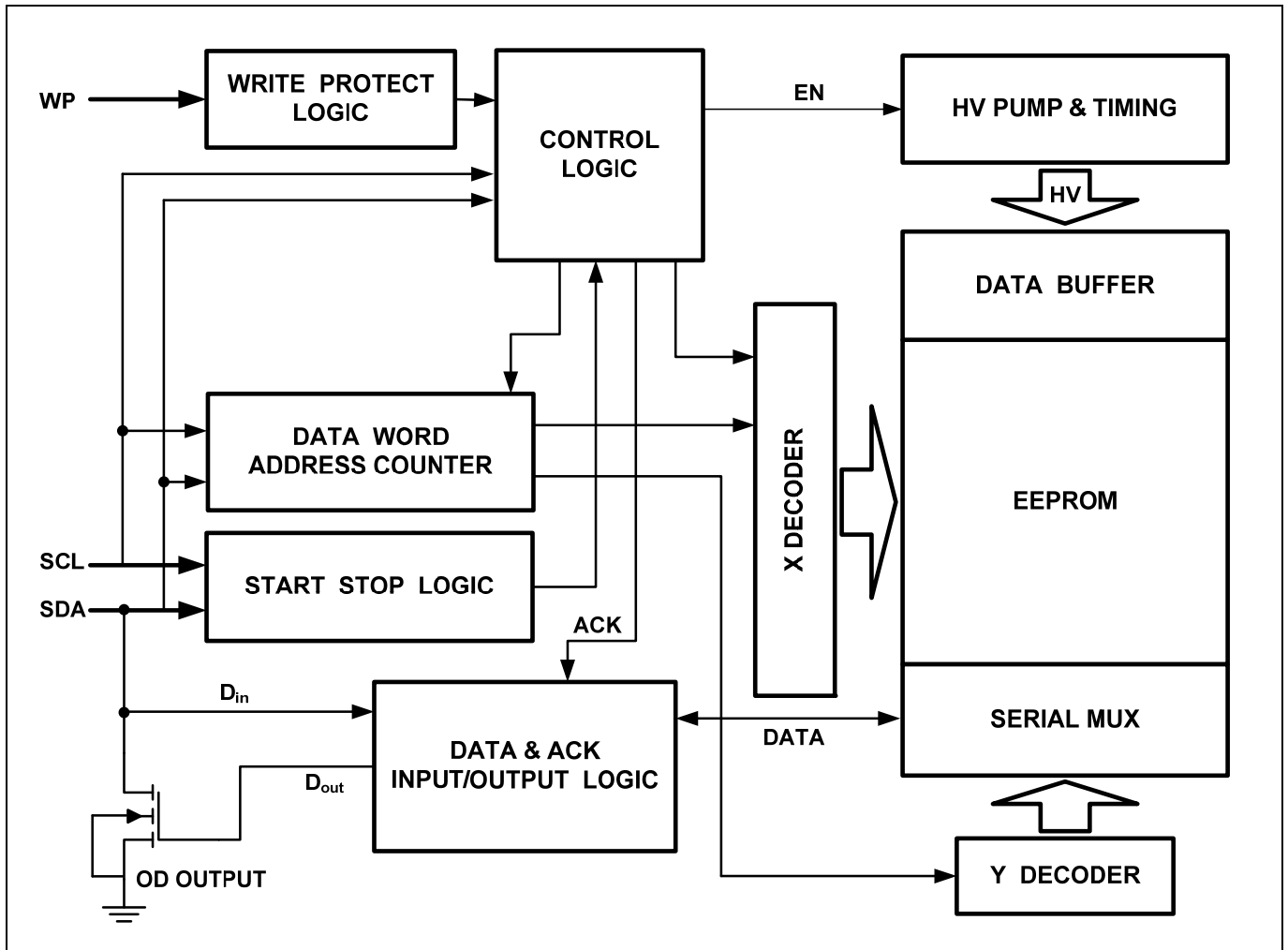

## Pin Description

**SERIAL CLOCK (SCL):** The SCL input is used to positive edge clock data into each EEPROM device and negative edge clock data out of each device.

**SERIAL DATA (SDA):** The SDA pin is bi-directional for serial data transfer. This pin is open-drain driven and may be wire-ORed with any number of other open-drain or open-collector devices.

**WRITE PROTECT (WP):** The FM24C02A has a Write Protect pin that provides hardware data protection. The Write Protect pin allows normal read/write operations when connected to ground (GND). When the Write Protect pin is connected to  $V_{CC}$ , the write protection feature is enabled.

## Write Protect Description

WP Pin Status	Part of the Array Protected
WP= $V_{CC}$	Full (2K) Array
WP=GND	Normal Read/Write Operations

## Memory Organization

**FM24C02A, 2K SERIAL EEPROM:** Internally organized with 32 pages of 8 bytes each, the 2K requires a 8-bit data word address for random word addressing.



## Pin Capacitance

Applicable over recommended operating range from:  $T_A = 25^\circ\text{C}$ ,  $f = 1.0\text{ MHz}$ ,  $V_{CC} = +1.7\text{V}$ .

Symbol	Test Condition	Max	Units	Conditions
$C_{I/O}^1$	Input/Output Capacitance (SDA)	8	pF	$V_{I/O} = 0\text{V}$
$C_{IN}^1$	Input Capacitance (SCL)	6	pF	$V_{IN} = 0\text{V}$

Note: 1. This parameter is characterized and is not 100% tested.

## DC Characteristics

Applicable over recommended operating range from:  $T_A = -40^\circ\text{C} \sim +85^\circ\text{C}$  (Plastic Package) /  $T_A = -20^\circ\text{C} \sim +60^\circ\text{C}$  (Module Package), (unless otherwise noted).

Symbol	Parameter	Test Condition	Min	Typ	Max	Units
$V_{CC}$	Supply Voltage		1.7		5.5	V
$I_{CC1}$	Supply Current	$V_{CC} = 5.0\text{V}$ , Read at 400K		0.4	1.0	mA
$I_{CC2}$	Supply Current	$V_{CC} = 5.0\text{V}$ , Write at 400K		2.0	3.0	mA
$I_{SB1}$	Standby Current	$V_{CC} = 1.7\text{V}$ , $V_{IN} = V_{CC}/V_{SS}$		3.0	6.0	$\mu\text{A}$
$I_{SB2}$	Standby Current	$V_{CC} = 5.5\text{V}$ , $V_{IN} = V_{CC}/V_{SS}$		8.0	18.0	$\mu\text{A}$
$I_{LI}$	Input Leakage Current	$V_{IN} = V_{CC}/V_{SS}$		0.1	3.0	$\mu\text{A}$
$I_{LO}$	Output Leakage Current	$V_{OUT} = V_{CC}/V_{SS}$		0.05	3.0	$\mu\text{A}$
$V_{IL}^1$	Input Low Level		-0.6		$V_{CC} \times 0.3$	V
$V_{IH}^1$	Input High Level		$V_{CC} \times 0.7$		5.5	V
$V_{OL2}$	Output Low Level	$V_{CC} = 3.0\text{V}$ , $I_{OL} = 2.1\text{ mA}$			0.4	V
$V_{OL1}$	Output Low Level	$V_{CC} = 1.7\text{V}$ , $I_{OL} = 0.15\text{ mA}$			0.2	V

Note: 1.  $V_{IL}$  min and  $V_{IH}$  max are reference only and are not tested.

## AC Characteristics

Applicable over recommended operating range from:  $T_A = -40^{\circ}\text{C} \sim +85^{\circ}\text{C}$  (Plastic Package) /  $T_A = -20^{\circ}\text{C} \sim +60^{\circ}\text{C}$  (Module Package),  $V_{CC} = +1.7\text{V}$  to  $+5.5\text{V}$ ,  $CL = 100\text{ pF}$  (unless otherwise noted). Test conditions are listed in Note 2.

Symbol	Parameter	1.7-volt		2.5-volt		5.5-volt		Units
		Min	Max	Min	Max	Min	Max	
$f_{SCL}$	Clock Frequency, SCL		400		1000		1000	kHz
$t_{LOW}$	Clock Pulse Width Low	1.3		0.4		0.4		$\mu\text{s}$
$t_{HIGH}$	Clock Pulse Width High	0.6		0.4		0.4		$\mu\text{s}$
$t_{AA}$	Clock Low to Data Out Valid	0.05	0.9	0.05	0.55	0.05	0.55	$\mu\text{s}$
$t_{BUF}^1$	Time the bus must be free before a new transmission can Start	1.2		0.5		0.5		$\mu\text{s}$
$t_{HD.STA}$	Start Hold Time	0.6		0.25		0.25		$\mu\text{s}$
$t_{SU.STA}$	Start Setup Time	0.6		0.25		0.25		$\mu\text{s}$
$t_{HD.DAT}$	Data In Hold Time	0		0		0		$\mu\text{s}$
$t_{SU.DAT}$	Data In Setup Time	100		100		100		ns
$t_R$	Inputs Rise Time		0.3		0.3		0.3	$\mu\text{s}$
$t_F$	Inputs Fall Time		300		100		100	ns
$t_{SU.STO}$	Stop Setup Time	0.6		0.25		0.25		$\mu\text{s}$
$t_{DH}$	Data Out Hold Time	50		50		20		ns
$t_{WR}$	Write Cycle Time		5		5		5	ms
Endurance <sup>1</sup>	3.3V, 25°C, Page Mode	1,000,000						Write Cycles

Notes: 1. This parameter is characterized and is not 100% tested.

2. AC measurement conditions:

RL (connects to  $V_{CC}$ ): 1.3 k $\Omega$

Input pulse voltages: 0.3  $V_{CC}$  to 0.7  $V_{CC}$

Input rise and fall times:  $\leq 50\text{ ns}$

Input and output timing reference voltages: 0.5  $V_{CC}$

## Device Operation

**CLOCK and DATA TRANSITIONS:** The SDA pin is normally pulled high with an external device. Data on the SDA pin may change only during SCL low time periods (refer to Figure 4). Data changes during SCL high periods will indicate a start or stop condition as defined below.

**START CONDITION:** A high-to-low transition of SDA with SCL high is a start condition which must precede any other command (refer to Figure 5).

**STOP CONDITION:** A low-to-high transition of SDA with SCL high is a stop condition. After a read sequence, the stop command will place the EEPROM in a standby power mode (refer to Figure 5).

**ACKNOWLEDGE:** All addresses and data words are serially transmitted to and from the EEPROM in 8-bit words. The EEPROM sends a zero to acknowledge that it has received each word. This happens

during the ninth clock cycle. Following receipt each word from the EEPROM, the microcontroller should send a zero to EEPROM and continue to output the next data word or send a stop condition to finish the read cycle.

**STANDBY MODE:** The FM24C02A features a low-power standby mode which is enabled: (a) upon power-up and (b) after the receipt of the stop bit and the completion of any internal operations.

**DEVICE RESET:** After an interruption in protocol, power loss or system reset, any two-wire part can be reset in following these steps:

1. Clock up to 9 Cycles,
2. Look for SDA high in each cycle while SCL is high and then,
3. Create a start condition as SDA is high.

## Bus Timing

Figure 2. SCL: Serial Clock, SDA: Serial Data I/O

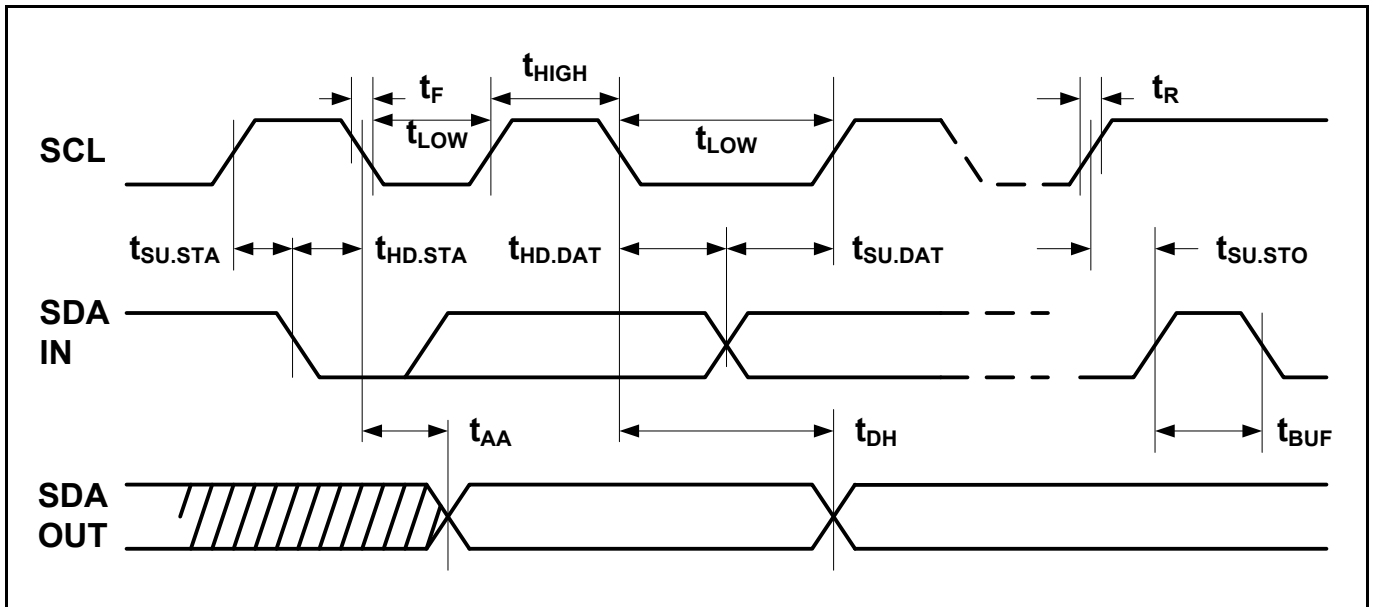



## Write Cycle Timing

Figure 3. SCL: Serial Clock, SDA: Serial Data I/O

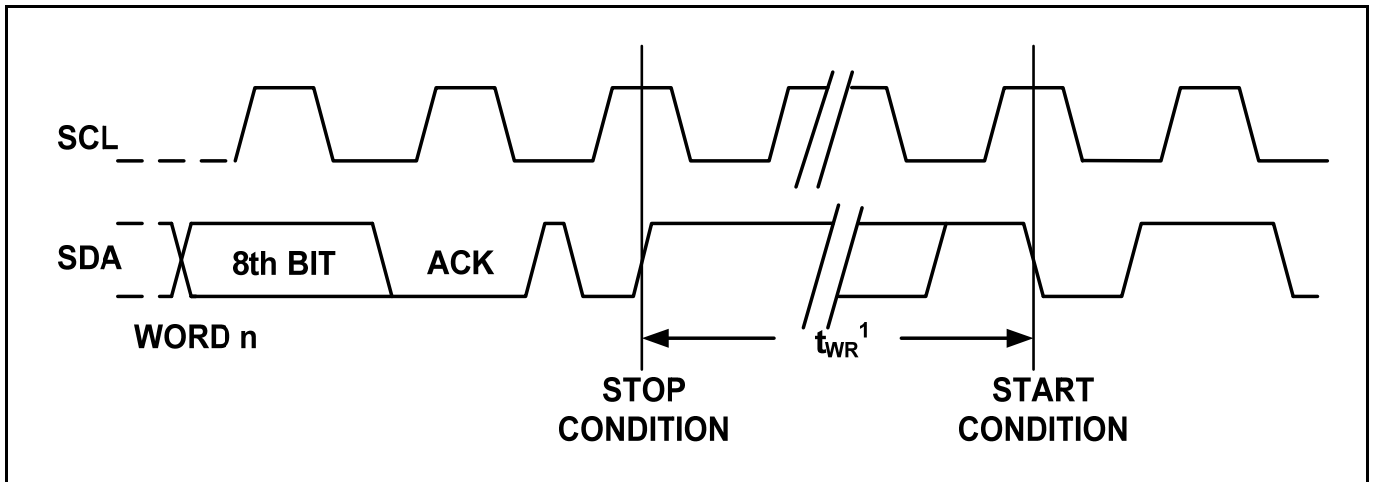

Note: 1. The write cycle time  $t_{WR}$  is the time from a valid stop condition of a write sequence to the end of the internal clear/write cycle.

Figure 4. Data Validity

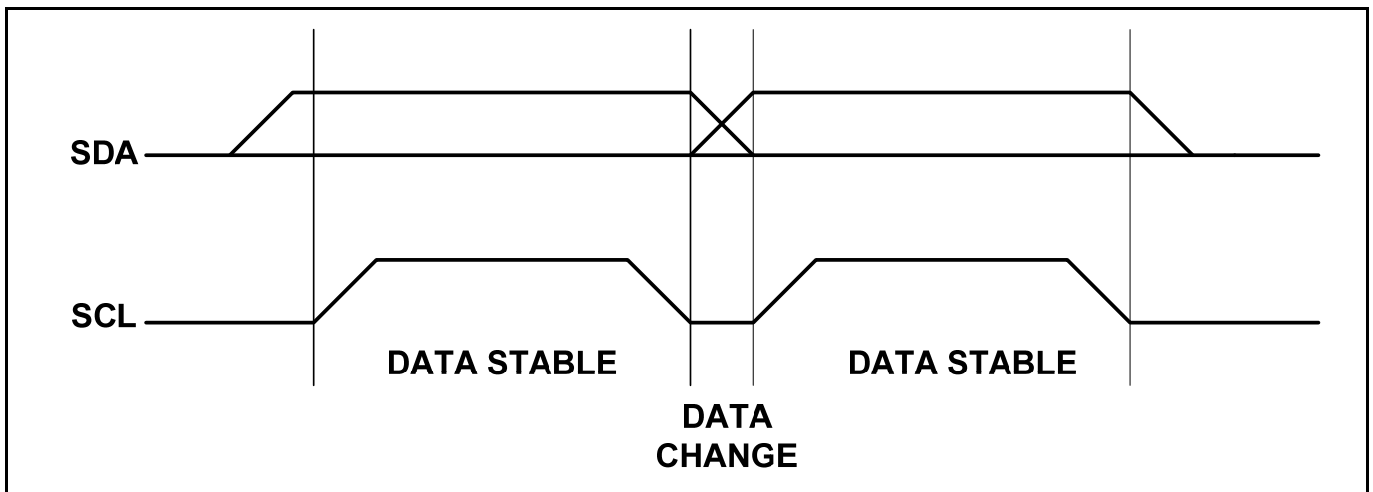
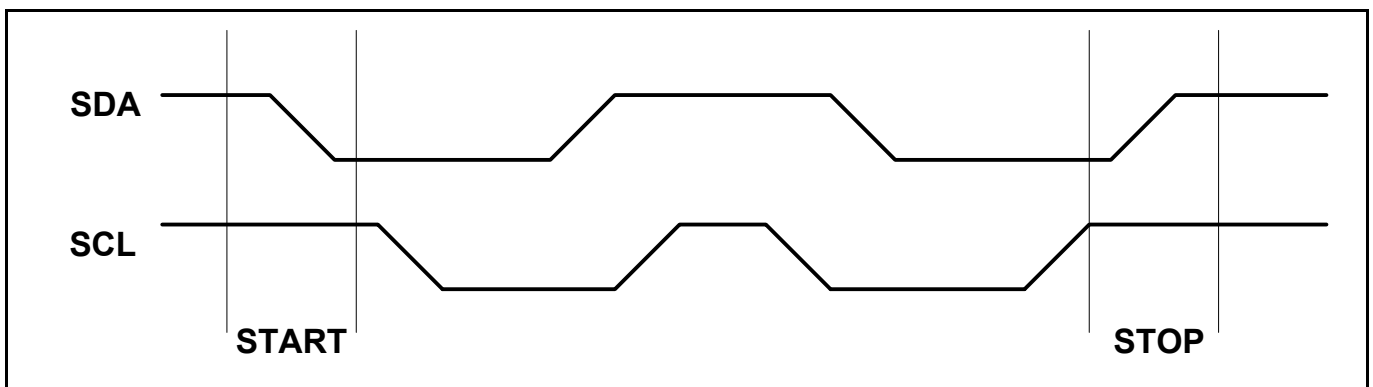
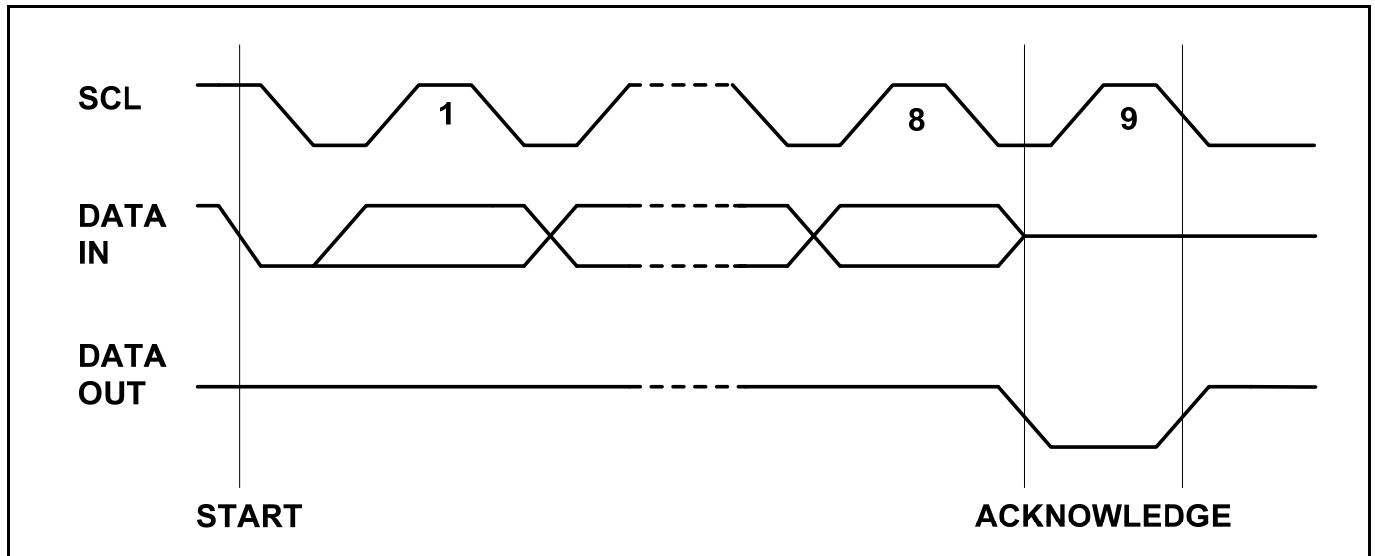

Figure 5. Start and Stop Definition



**Figure 6. Output Acknowledge**

## Device Addressing

The 2K EEPROM device requires an 8-bit device address word following a start condition to enable the chip for a read or write operation (refer to Figure 7).

The device address word consists of a mandatory one, zero sequence for the first four most significant bits as shown. This is common to all the EEPROM devices. The next 3 bits can be any data.

The eighth bit of the device address is the read/write operation select bit. A read operation is initiated if this bit is high and a write operation is initiated if this bit is low.

Upon a compare of the device address, the EEPROM will output a zero.

## Write Operations

**BYTE WRITE:** A write operation requires an 8-bit data word address following the device address word and acknowledgment. Upon receipt of this address, the EEPROM will again respond with a zero and then clock in the first 8-bit data word. Following receipt of the 8-bit data word, the EEPROM will output a zero and the addressing device, such as a microcontroller, must terminate the write sequence with a stop condition. At this time the EEPROM enters an internally timed write cycle,  $t_{WR}$ , to the nonvolatile memory. All inputs are disabled during this write cycle and the EEPROM will not respond until the write is complete (refer to Figure 8).

**PAGE WRITE:** The 2K devices are capable of 8-byte page writes.

A page write is initiated the same as a byte write, but the microcontroller does not send a stop condition after the first data word is clocked in. Instead, after the EEPROM acknowledges receipt of the first data word, the microcontroller can transmit up to seven more data words. The EEPROM will respond with a zero after each data word received. The microcontroller must terminate the page write sequence with a stop condition (refer to Figure 9).

The data word address lower three bits are internally incremented following the receipt of each data word. The higher data word address bits are not incremented, retaining the memory page row location. When the word address, internally generated, reaches the page boundary, the following byte is placed at the beginning of the same page. If more than eight data words are transmitted to the EEPROM, the data word address will “roll over” and previous data will be overwritten.

**ACKNOWLEDGE POLLING:** Once the internally timed write cycle has started and the EEPROM inputs are disabled, acknowledge polling can be initiated. This involves sending a start condition followed by the device address word. The read/write bit is representative of the operation desired. Only if the internal write cycle has completed will the EEPROM respond with a zero allowing the read or write sequence to continue.

## Read Operations

Read operations are initiated the same way as write operations with the exception that the read/write select bit in the device address word is set to one. There are three read operations: current address read, random address read and sequential read.

**CURRENT ADDRESS READ:** The internal data word address counter maintains the last address accessed during the last read or write operation, incremented by one. This address stays valid between operations as long as the chip power is maintained. The address “roll over” during read is from the last byte of the last memory page to the first byte of the first page. The address “roll over” during write is from the last byte of the current page to the first byte of the same page.

Once the device address with the read/write select bit set to one is clocked in and acknowledged by the EEPROM, the current address data word is serially clocked out. The microcontroller does not respond with an input zero but does generate a following stop condition (refer to Figure 10).

**RANDOM READ:** A random read requires a “dummy” byte write sequence to load in the data word address. Once the device address word and data word address are clocked in and acknowledged by the EEPROM, the microcontroller must generate another start condition. The microcontroller now initiates a current address read by sending a device address with the read/write select bit high. The EEPROM acknowledges the device address and serially clocks out the data word. The microcontroller does not respond with a zero but does generate a following stop condition (refer to Figure 11).

**SEQUENTIAL READ:** Sequential reads are initiated by either a current address read or a random address read. After the microcontroller receives a data word, it responds with an acknowledge. As long as the EEPROM receives an acknowledge, it will continue to increment the data word address and serially clock out sequential data words. When the memory address limit is reached, the data word address will “roll over” and the sequential read will continue. The sequential read operation is terminated when the microcontroller does not respond with a zero but does generate a following stop condition (refer to Figure 12)

Figure 7. Device Address

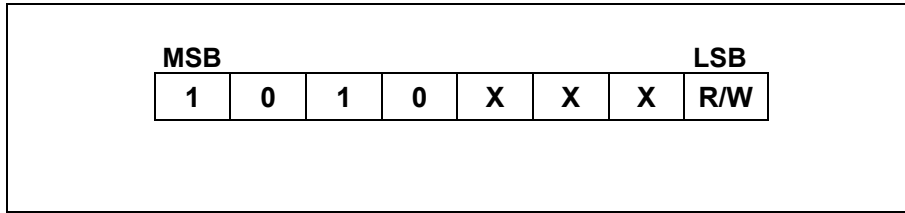

Figure 8. Byte Write

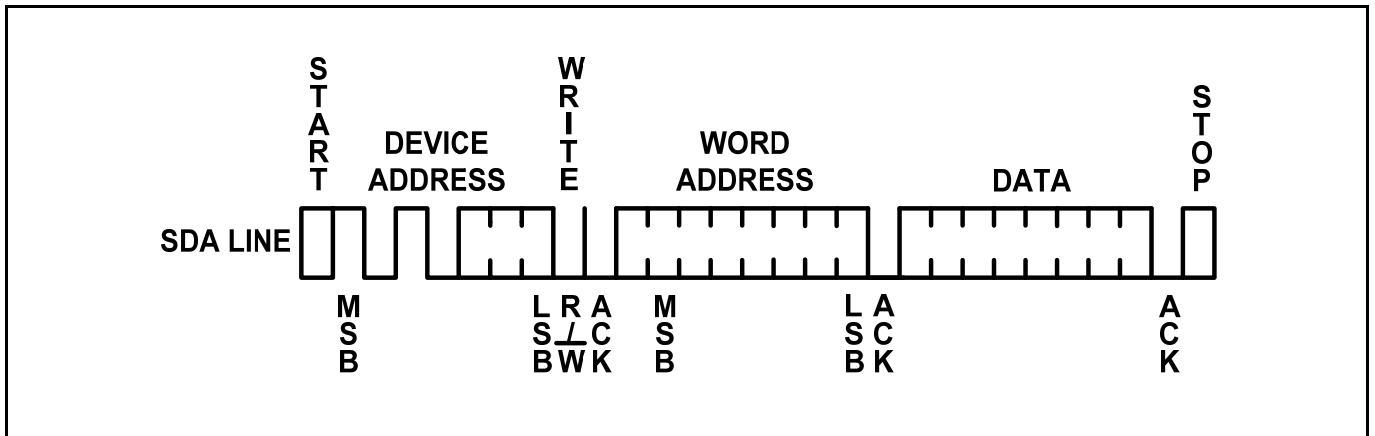

Figure 9. Page Write

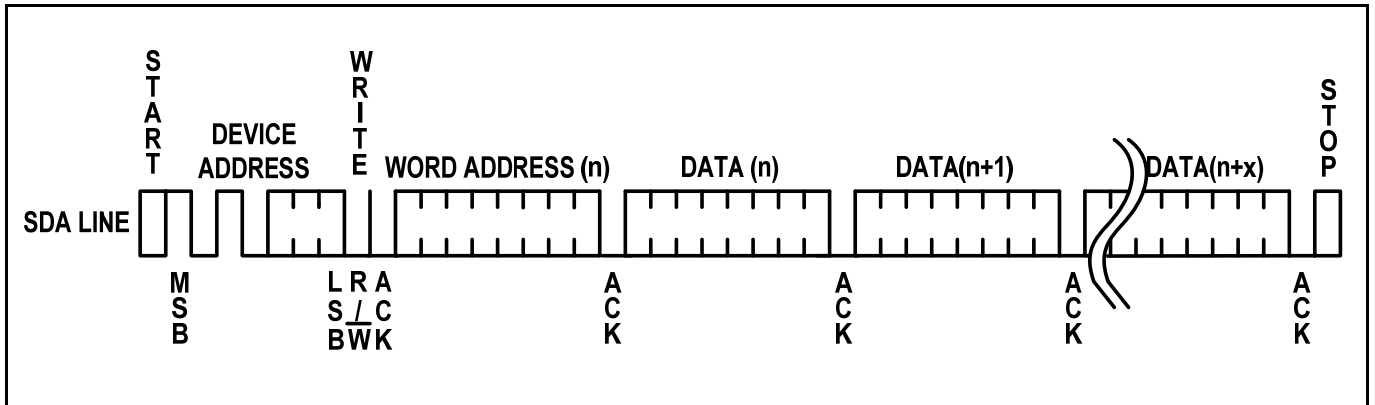

Figure 10. Current Address Read

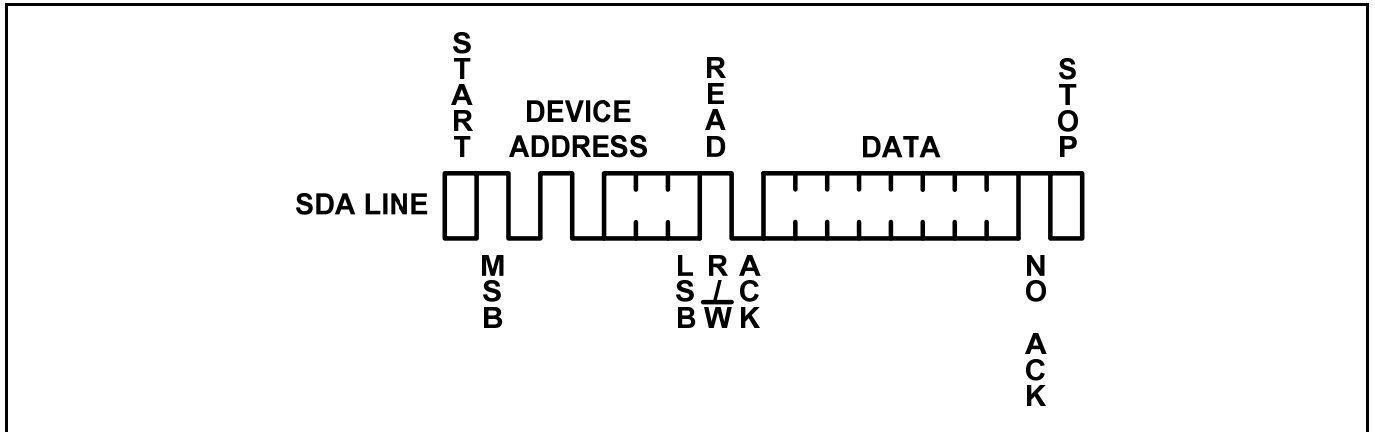

Figure 11. Random Read

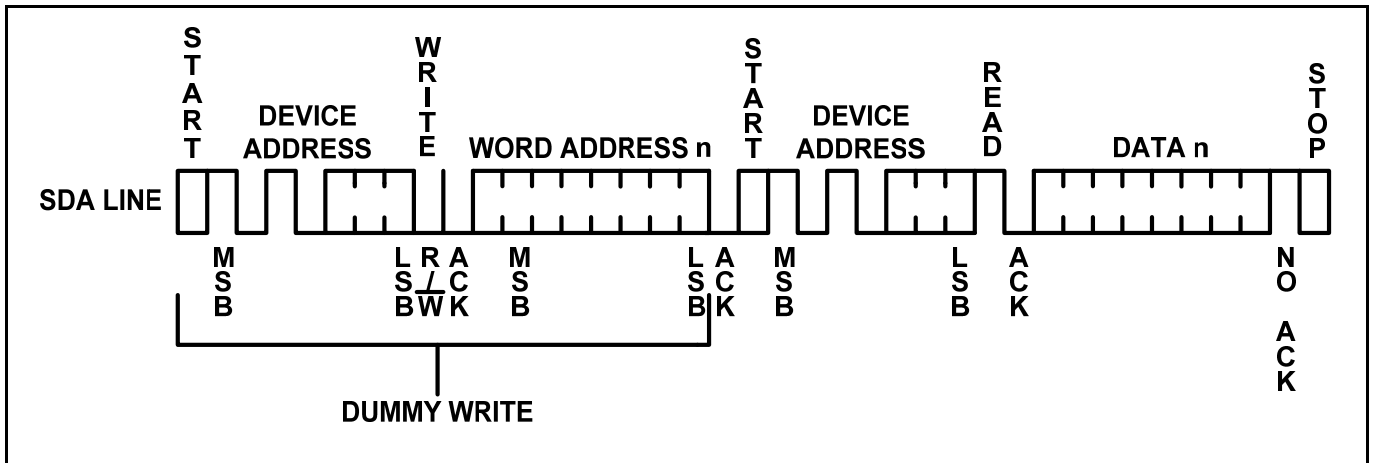
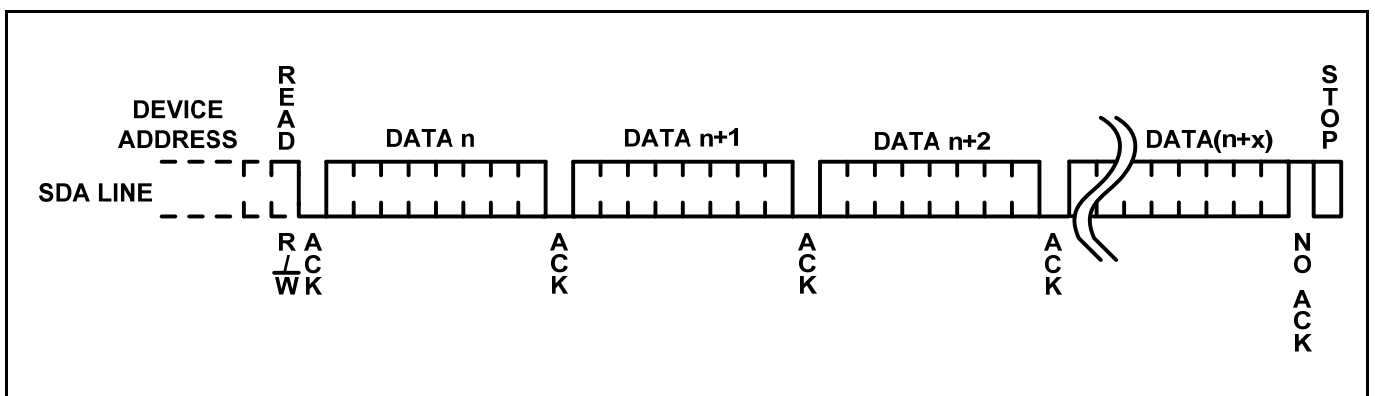

Figure 12. Sequential Read





## Ordering Information

	FM	24C	02	A	-PP	-C	-H
<b>Company Prefix</b>							
FM = Fudan Microelectronics Co.,Ltd							
<b>Product Family</b>							
24C = 2-Wire Serial EEPROM							
<b>Product Density</b>							
02 = 2K-bit							
<b>Supply Voltage</b>							
A = 1.7V to 5.5V							
<b>Package Type</b>							
PD = 8-pin PDIP	M2F or M2P = 8-pin Module Package <sup>(1)</sup>						
SO = 8-pin SOP	M3F or M3P = 6-pin Module Package <sup>(1)</sup>						
TS = 8-pin TSSOP							
<b>Product Carrier</b>							
U = Tube							
T = Tape and Reel							
R = Module Reel							
<b>HSF ID Code</b>							
Blank or R = RoHS Compliant							
G = RoHS Compliant, Halogen-free, Antimony-free							

Note: 1. For the details of Module package please contact local sales office.

## Part Marking Scheme

### PDIP8

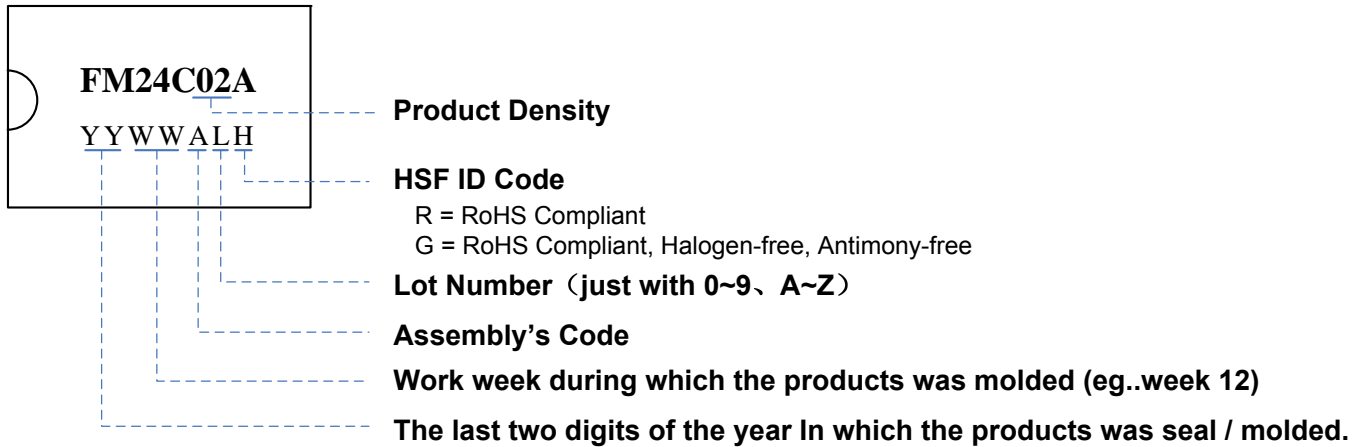

### SOP8

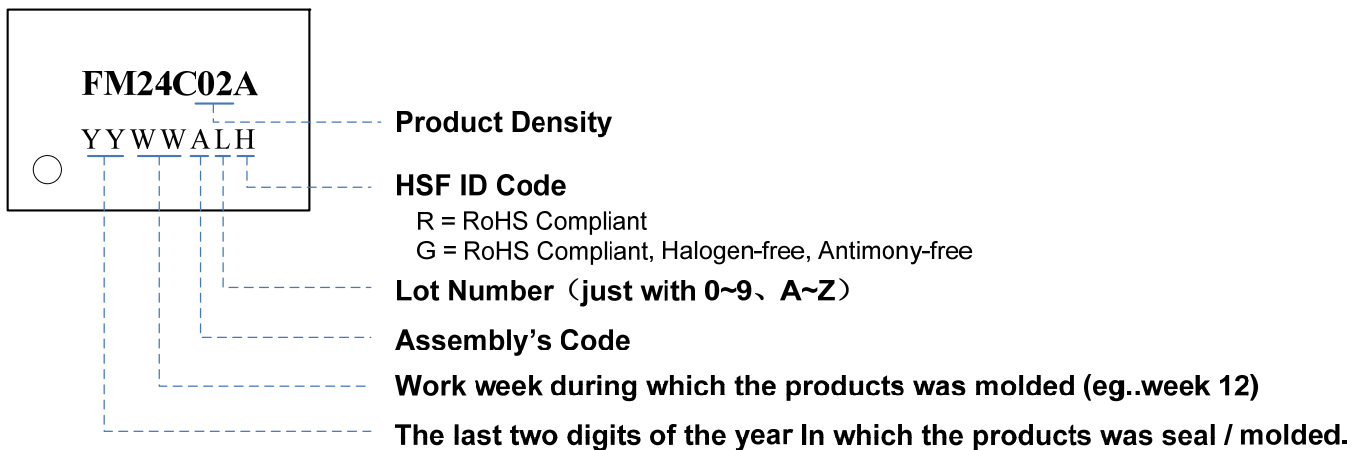

### TSSOP8

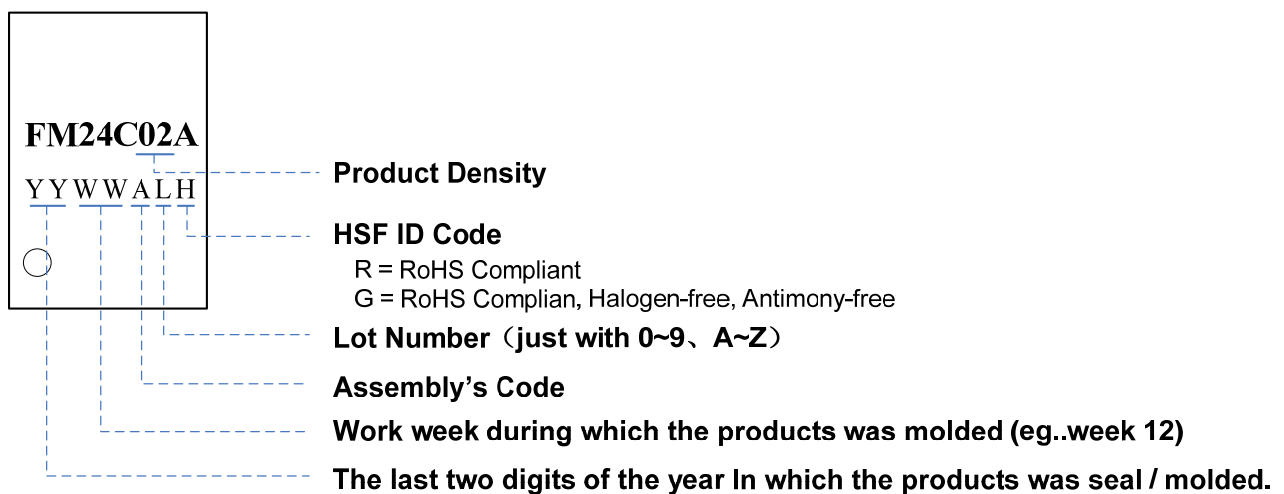

## Packaging Information

### PDIP 8

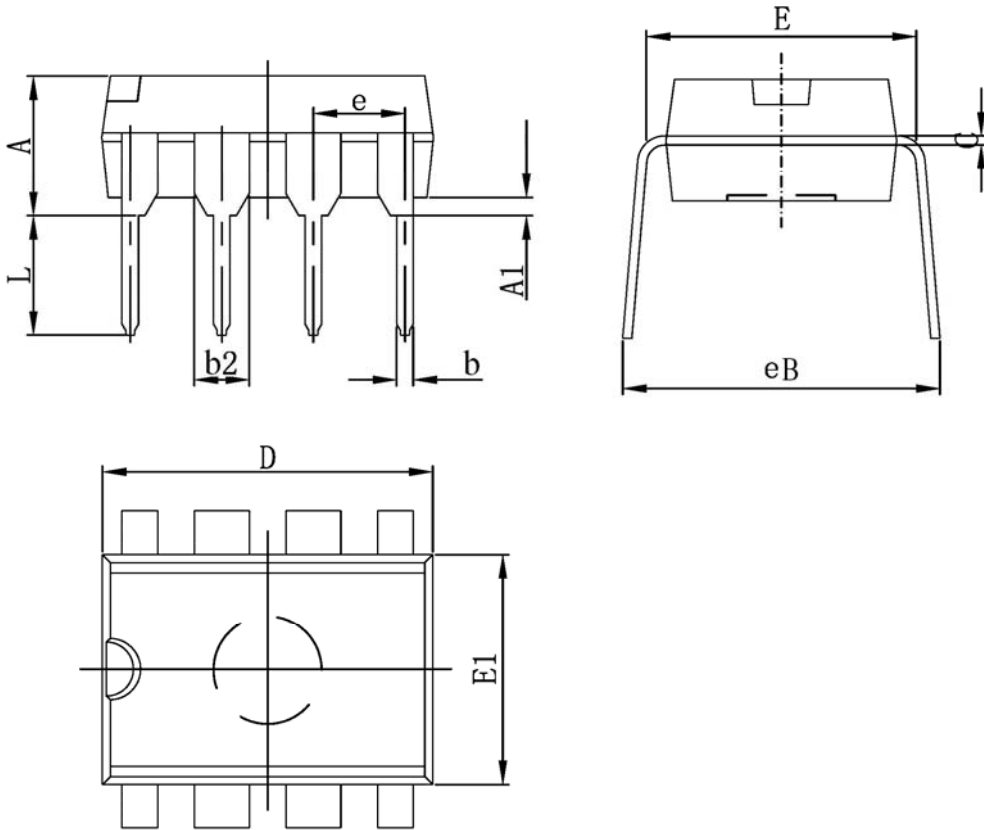

Symbol	MIN	MAX
A	3.710	4.310
A1	0.510	
b	0.380	0.570
b2	1.524(BSC)	
C	0.204	0.360
D	9.000	9.400
E1	6.200	6.600
E	7.320	7.920
e	2.540(BSC)	
L	3.000	3.600
eB	8.400	9.000

**NOTE:**

1. Dimensions are in Millimeters.



## SOP 8

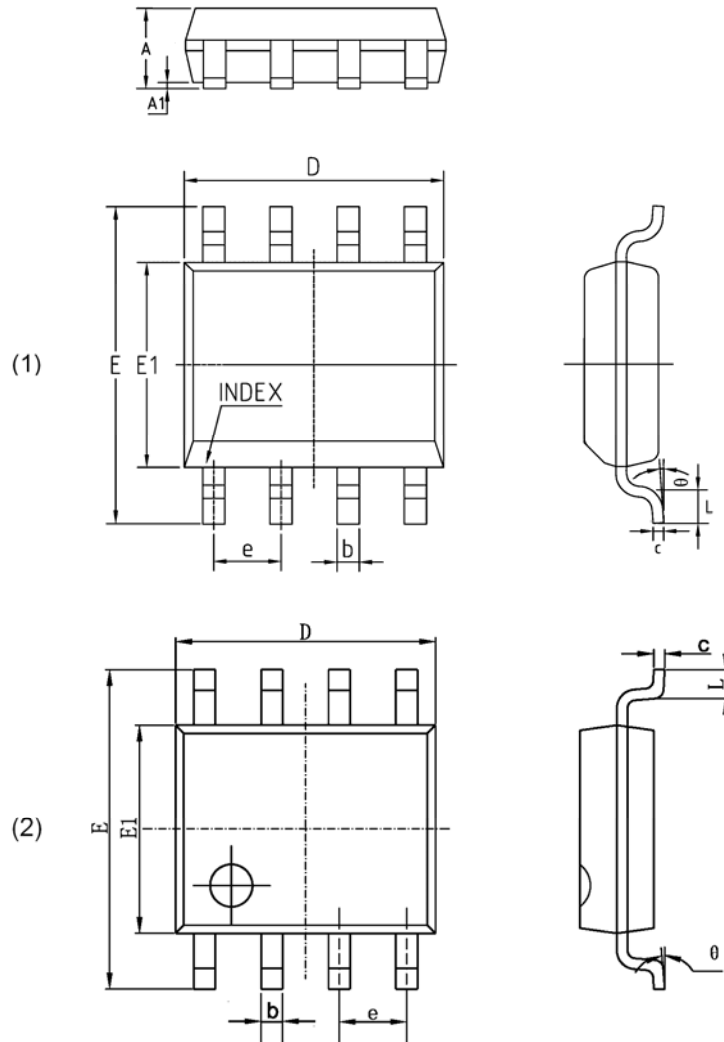

Symbol	MIN	MAX
A	1.350	1.750
A1	0.050	0.250
b	0.330	0.510
c	0.150	0.250
D	4.700	5.150
E1	3.800	4.000
E	5.800	6.200
e	1.270(BSC)	
L	0.400	1.270
$\theta$	0°	8°

## NOTE:

1. Dimensions are in Millimeters.

## TSSOP8

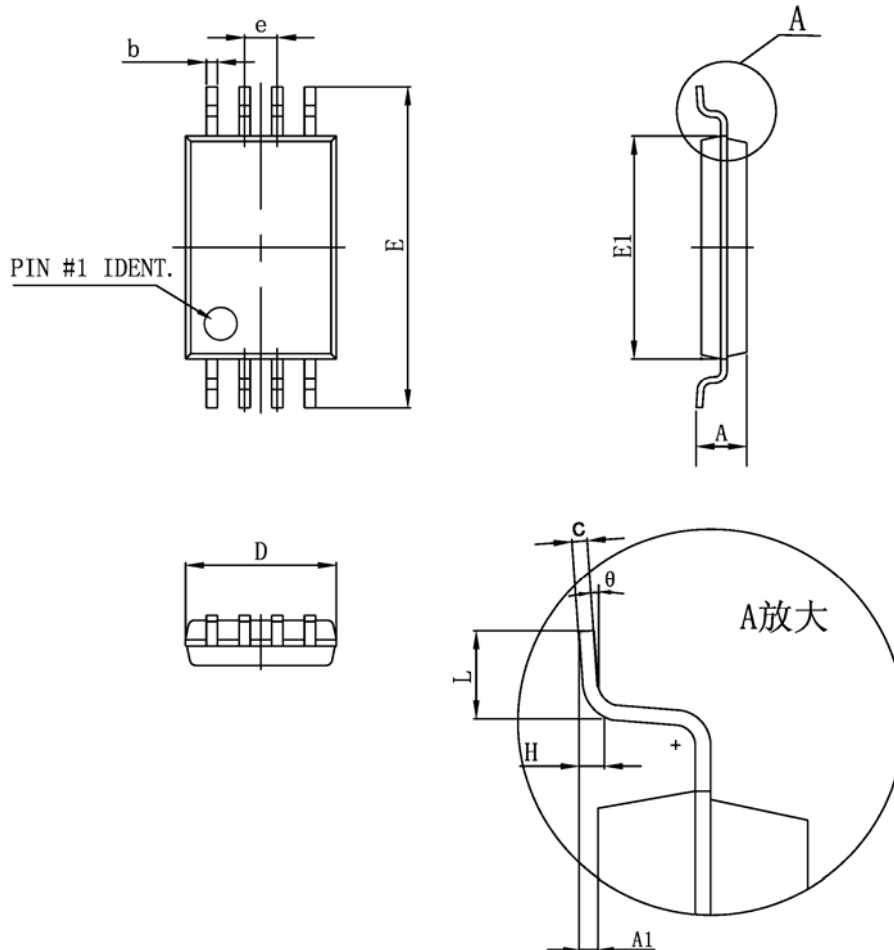

Symbol	MIN	MAX
D	2.830	3.100
E1	4.300	4.500
b	0.190	0.300
c	0.090	0.200
E	6.200	6.600
A		1.200
A1	0.050	0.150
e	0.650 (BSC)	
L	0.450	0.750
$\theta$	0°	8°

## NOTE:

1. Dimensions are in Millimeters.



## Revision History

Version	Publication date	Pages	Paragraph or Illustration	Revise Description
	Dec. 2008	20		Preliminary
1.0	Jun. 2009	20	Packing Type AC Characteristics	1. Added the 6-Pin Module package. 2. Updated the AC Characteristics
1.1	July. 2009	20	Pin Configurations Device Addressing	1. Updated the Pin Configurations 2. Added the description of device addressing for Module package device.
1.2	Sep. 2009	20	Packaging Information	Updated the Packaging Information.
1.3	Apr.2010	20	Device Addressing Packaging Information	Updated "Device addressing" and "Packaging Information "
1.4	May. 2011	20	"AC Characteristics" "Part Marking Scheme" "Packaging Information" "Part marking scheme" "Sales and Service"	1. Updated the "AC Characteristics". 2. Updated the "Part Marking Scheme" 3. Updated the "Packaging Information" 4. Updated the address of Beijing office. 5. The company changed its name to Shanghai Fudan Microelectronics Group Co., Ltd.
1.5	May. 2012	20	"Disclaimer" "Packaging Information"	1. Modified the Disclaimer. 2. Updated the Packaging Information of TSSOP8.



## Sales and Service

### Shanghai Fudan Microelectronics Group Co., Ltd.

Address: Bldg No. 4, 127 Guotai Rd,  
Shanghai City China.

Postcode: 200433

Tel: (86-021) 6565 5050

Fax: (86-021) 6565 9115

### Shanghai Fudan Microelectronics (HK) Co., Ltd.

Address: Unit 506, 5/F., East Ocean Centre, 98 Granville  
Road, Tsimshatsui East, Kowloon, Hong Kong

Tel: (852) 2116 3288 2116 3338

Fax: (852) 2116 0882

### Beijing Office

Address: Room 423, Bldg B, Gehua Building,  
1 QingLong Hutong, Dongzhimen Alley north Street,  
Dongcheng District, Beijing City, China.

Postcode: 100007

Tel: (86-10) 8418 6608 8418 7486

Fax: (86-10) 8418 6211

### Shenzhen Office

Address: Room.1301, Century Bldg, Shengtingyuan Hotel,  
Huaqiang Rd (North),  
Shenzhen City, China.

Postcode: 518028

Tel: (86-0755) 8335 3211 8335 6511

Fax: (86-0755) 8335 9011

**Web Site:** <http://www.fmsk.com/>