



复旦微电子

FM25LG02A
1.8V 2G-BIT SPI NAND FLASH
MEMORY

Datasheet

Jan. 2016

INFORMATION IN THIS DOCUMENT IS INTENDED AS A REFERENCE TO ASSIST OUR CUSTOMERS IN THE SELECTION OF SHANGHAI FUDAN MICROELECTRONICS GROUP CO., LTD PRODUCT BEST SUITED TO THE CUSTOMER'S APPLICATION; THEY DO NOT CONVEY ANY LICENSE UNDER ANY INTELLECTUAL PROPERTY RIGHTS, OR ANY OTHER RIGHTS, BELONGING TO SHANGHAI FUDAN MICROELECTRONICS GROUP CO., LTD OR A THIRD PARTY.

WHEN USING THE INFORMATION CONTAINED IN THIS DOCUMENTS, PLEASE BE SURE TO EVALUATE ALL INFORMATION AS A TOTAL SYSTEM BEFORE MAKING A FINAL DECISION ON THE APPLICABILITY OF THE INFORMATION AND PRODUCTS.

PURCHASERS ARE SOLELY RESPONSIBLE FOR THE CHOICE, SELECTION AND USE OF THE SHANGHAI FUDAN MICROELECTRONICS GROUP CO., LTD PRODUCTS AND SERVICES DESCRIBED HEREIN, AND SHANGHAI FUDAN MICROELECTRONICS GROUP CO., LTD ASSUMES NO LIABILITY WHATSOEVER RELATING TO THE CHOICE, SELECTION OR USE OF THE SHANGHAI FUDAN MICROELECTRONICS GROUP CO., LTD PRODUCTS AND SERVICES DESCRIBED HEREIN. UNLESS EXPRESSLY APPROVED IN WRITING BY AN AUTHORIZED SHANGHAI FUDAN MICROELECTRONICS GROUP CO., LTD REPRESENTATIVE, SHANGHAI FUDAN MICROELECTRONICS GROUP CO., LTD PRODUCTS ARE NOT RECOMMENDED, AUTHORIZED OR WARRANTED FOR USE IN MILITARY, AIR CRAFT, SPACE, LIFE SAVING, OR LIFE SUSTAINING APPLICATIONS, NOR IN PRODUCTS OR SYSTEMS WHERE FAILURE OR MALFUNCTION MAY RESULT IN PERSONAL INJURY, DEATH, OR SEVERE PROPERTY OR ENVIRONMENTAL DAMAGE.

FUTURE ROUTINE REVISIONS WILL OCCUR WHEN APPROPRIATE, WITHOUT NOTICE. CONTACT SHANGHAI FUDAN MICROELECTRONICS GROUP CO., LTD SALES OFFICE TO OBTAIN THE LATEST SPECIFICATIONS AND BEFORE PLACING YOUR PRODUCT ORDER. PLEASE ALSO PAY ATTENTION TO INFORMATION PUBLISHED BY SHANGHAI FUDAN MICROELECTRONICS GROUP CO., LTD BY VARIOUS MEANS, INCLUDING SHANGHAI FUDAN MICROELECTRONICS GROUP CO., LTD HOME PAGE ([HTTP://WWW.FMSH.COM/](http://www.fmsm.com/)).

PLEASE CONTACT SHANGHAI FUDAN MICROELECTRONICS GROUP CO., LTD LOCAL SALES OFFICE FOR THE SPECIFICATION REGARDING THE INFORMATION IN THIS DOCUMENT OR SHANGHAI FUDAN MICROELECTRONICS GROUP CO., LTD PRODUCTS.

Trademarks

Shanghai Fudan Microelectronics Group Co., Ltd name and logo, the “复旦” logo are trademarks or registered trademarks of Shanghai Fudan Microelectronics Group Co., Ltd or its subsidiaries in China.

Shanghai Fudan Microelectronics Group Co., Ltd, Printed in the China, All Rights Reserved.

1. Description

The FM25LG02A is a 2G-bit (256M-byte) SPI (Serial Peripheral Interface) NAND Flash memory, with advanced write protection mechanisms. The FM25LG02A supports the standard Serial Peripheral Interface (SPI), Dual/Quad I/O option.

2. Features

- **2G-bit NAND Flash Memory**
 - Single-level cell (SLC) technology
 - Page size : 2176 bytes(2048 + 128 bytes)
 - Block size : 64 pages(128K + 8K bytes)
 - Device size: 2Gb(2048 blocks)
- **Serial Interface**
 - Standard SPI: CLK, CS#, DI, DO, WP#
 - Dual SPI: CLK, CS#, DQ0, DQ1, WP#
 - Quad SPI: CLK, CS#, DQ0, DQ1, DQ2, DQ3
- **High Performance**
 - 88MHz for fast read
 - Quad I/O data transfer up to 480Mbits/s
 - 2176/2048/64/16 wrap read option
 - 2K-Byte cache for fast random read
- **Advanced Security Features**
 - Write protect all/portion of memory via software
 - Individual Block array protection
 - Lockable 16K-Byte OTP region
 - 64-Bit Unique ID for each device
- **Program/Erase/Read Speed**
 - PAGE PROGRAM time : 400μs typical (without ECC)
 - BLOCK ERASE time : 3ms typical
 - PAGE READ time : 120μs typical (without ECC)
- **Single Supply Voltage : 1.7V~1.95V**
- **Advanced Features for NAND**
 - Internal ECC option, per 512 bytes
 - INTERNAL DATA MOVE by page with ECC
 - Promised golden block0
- **Package**
 - TDFN8 (8x6mm)
 - All Packages are RoHS Compliant and Halogen-free
- **Minimum 100,000 Program/Erase Cycles**
- **Data Retention: 20 years**

3. Packaging Type and Pin Configurations

FM25LG02A is offered in a TDFN8 (8x6mm) as shown in Figure 1. Package diagram and dimension are illustrated at the end of this datasheet.

Figure 1 Pad Assignments, TDFN8 (8x6mm)

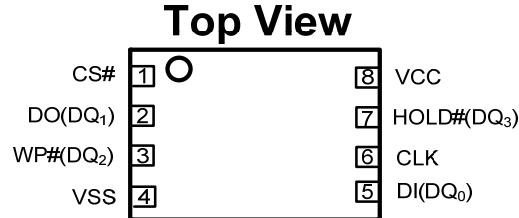

3.1. Pin Description

Table 1 Pin Description

PIN NO.	PIN NAME	I/O	FUNCTION
1	CS#	I	Chip Select Input
2	DO (DQ ₁)	I/O	Data Output (Data Input Output 1) ⁽¹⁾
3	WP# (DQ ₂)	I/O	Write Protect Input (Data Input Output 2) ⁽²⁾
4	VSS		Ground
5	DI (DQ ₀)	I/O	Data Input (Data Input Output 0) ⁽¹⁾
6	CLK	I	Serial Clock Input
7	HOLD# (DQ ₃)	I/O	Hold Input (Data Input Output 3) ⁽²⁾
8	VCC		Power Supply

Note:

1 DQ₀ and DQ₁ are used for Dual SPI instructions.

2 DQ₀ – DQ₃ are used for Quad SPI instructions.

4. Block Diagram

Figure 2 SPI NAND Flash Memory Block Diagram

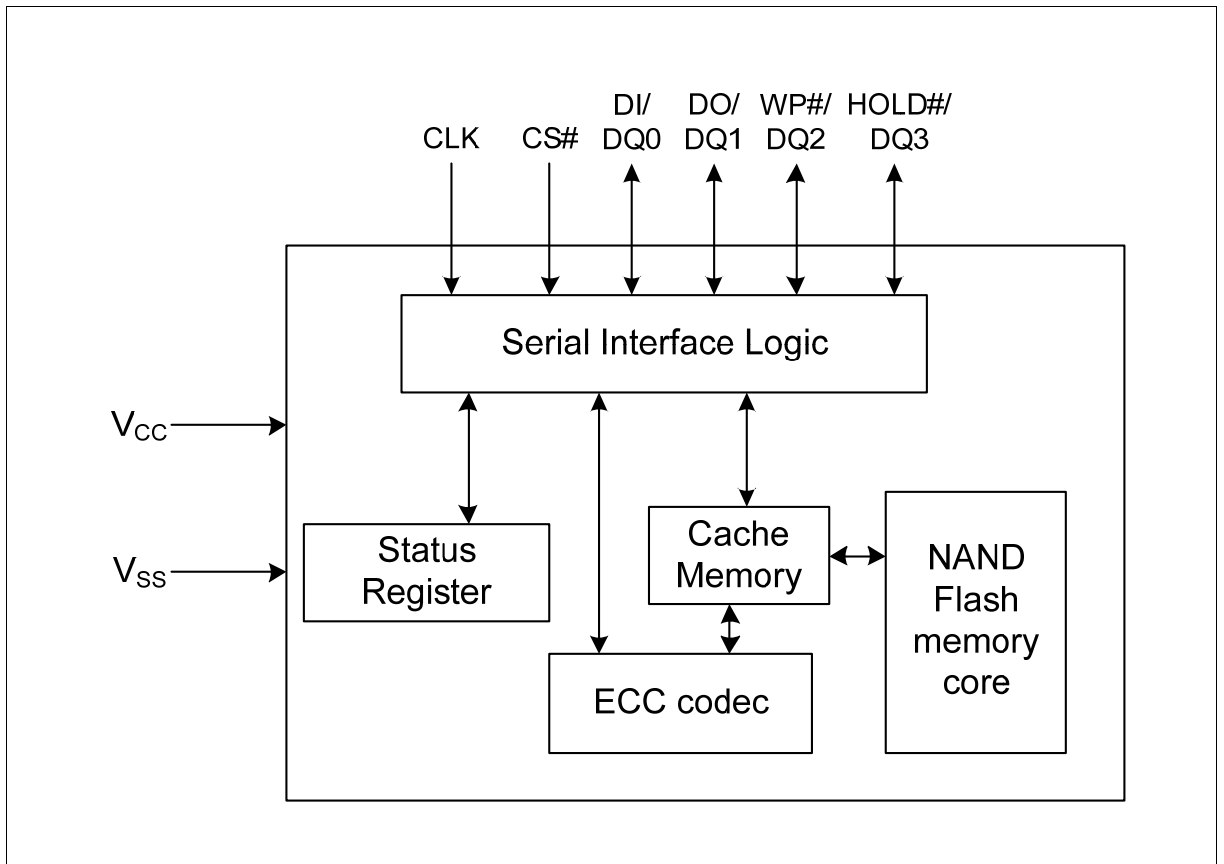

5. Memory Mapping

Figure 3 Memory Map

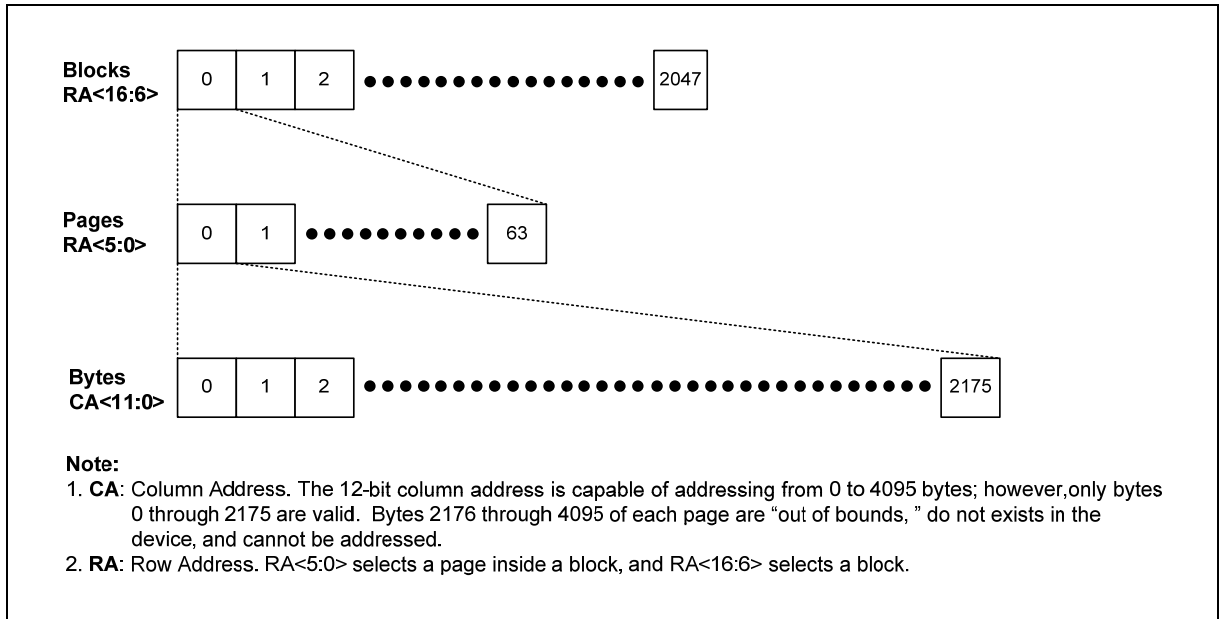

6. Array Organization

Table 2 Array Organization

Each device has	Each block has	Each page has	Unit
256M + 16M	128K + 8K	2K + 128	bytes
2048 x 64	64	-	Pages
2048	-	-	Blocks

Figure 4 Array Organization

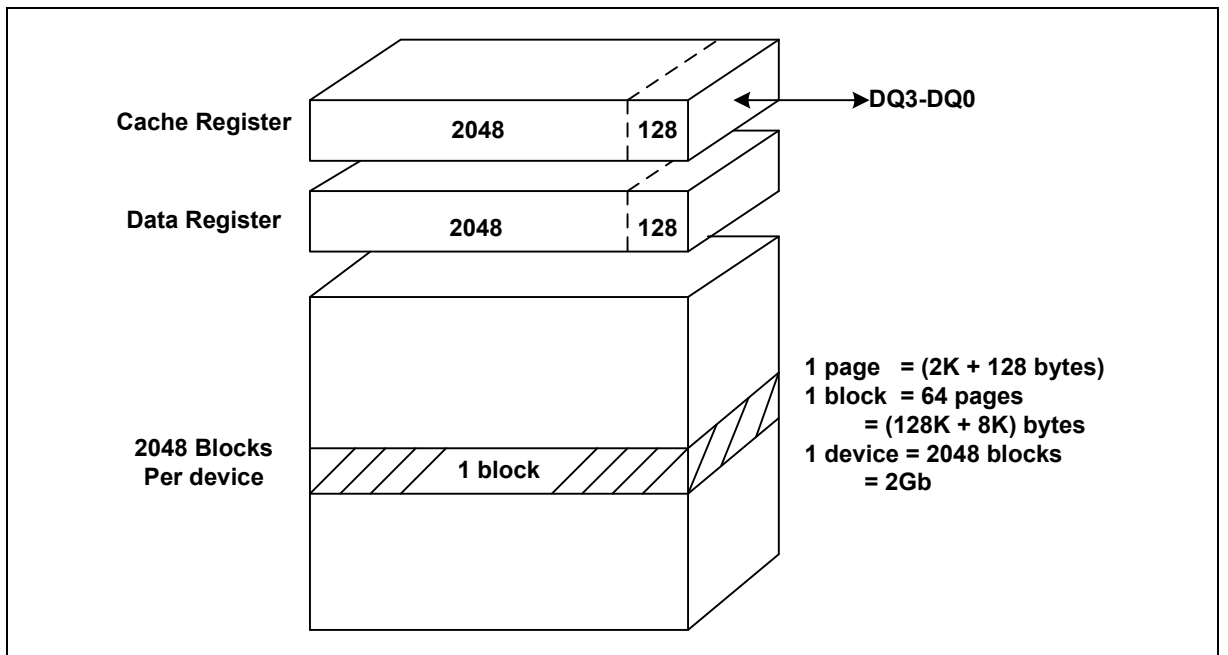

7. Device Operations

7.1. Single Data Rate (SDR)

7.1.1. Standard SPI

The FM25LG02A is accessed through an SPI compatible bus consisting of four signals: Serial Clock (CLK), Chip Select (CS#), Serial Data Input (DI) and Serial Data Output (DO). Standard SPI instructions use the DI input pin to serially write instructions, addresses or data to the device on the rising edge of CLK. The DO output pin is used to read data or status from the device on the falling edge of CLK.

SPI bus operation Mode 0 (0,0) and 3 (1,1) are supported. The primary difference between Mode 0 and Mode 3 concerns the normal state of the CLK signal when the SPI bus master is in standby and data is not being transferred to the Serial Flash. For Mode 0, the CLK signal is normally low on the falling and rising edges of CS#. For Mode 3, the CLK signal is normally high on the falling and rising edges of CS#.

Figure 5 SPI SDR Modes Supported

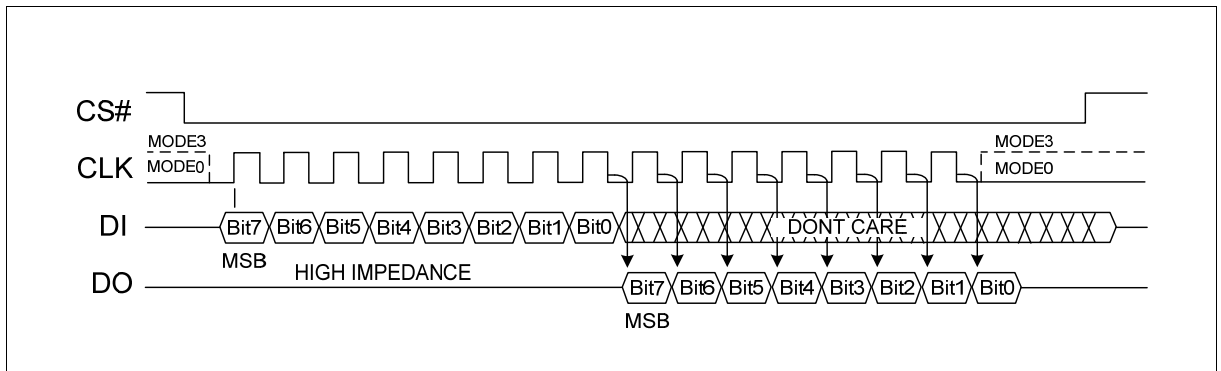

7.1.2. Dual SPI

The FM25LG02A supports Dual SPI operation when using the x2 and dual IO instructions. These instructions allow data to be transferred to or from the device at two times the rate of ordinary Serial Flash devices. When using Dual SPI instructions, the DI and DO pins become bidirectional I/O pins: DQ₀ and DQ₁.

7.1.3. Quad SPI

The FM25LG02A supports Quad SPI operation when using the x4 and Quad IO instructions. These instructions allow data to be transferred to or from the device four times the rate of ordinary Serial Flash. When using Quad SPI instructions the DI and DO pins become bidirectional DQ₀ and DQ₁ and the WP # and HOLD# pins become DQ₂ and DQ₃ respectively. Quad SPI instructions require the Quad Enable bit (QE) to be set.

7.2. CS#

The SPI Chip Select (CS#) pin enables and disables device operation. When CS# is high, the device is deselected and the Serial Data Output (DO, or DQ₀, DQ₁, DQ₂, DQ₃) pins are at high impedance. When deselected, the devices power consumption will be at standby levels unless an internal erase, program or write status register cycle is in progress. When CS# is brought low, the device will be selected, power consumption will increase to active levels and instructions can be written to and data read from the device. After power-up, CS# must transition from high to low before a new instruction will be accepted.

7.3. CLK

This input signal provides the synchronization reference for the SPI interface. Instructions, addresses, or data input are latched on the rising edge of the CLK signal. Data output changes after the falling edge of CLK.

7.4. Serial Input (DI) / DQ0

This input signal is used to transfer data serially into the device. It receives instructions, addresses, and data to be programmed. Values are latched on the rising edge of serial CLK clock signal.

DI becomes DQ0 - an input and output during Dual and Quad commands for receiving instructions, addresses, and data to be programmed (values latched on rising edge of serial CLK clock signal) as well as shifting out data (on the falling edge of CLK).

7.5. Serial Output (DO) / DQ1

This output signal is used to transfer data serially out of the device. Data is shifted out on the falling edge of the serial CLK clock signal.

DO becomes DQ1 - an input and output during Dual and Quad commands for receiving addresses, and data to be programmed (values latched on rising edge of serial CLK clock signal) as well as shifting out data (on the falling edge of CLK).

7.6. Write Protect (WP#) / DQ2

When WP# is driven Low (V_{IL}), during a SET FEATURES command and while the BRWD bit of the Status Register is set to a 1, it is not possible to write to the Status Registers. This prevents any alteration of the Block Protect (BP2, BP1, BP0), INV and CMP bits of the Status Register. As a consequence, all the data bytes in the memory area that are protected by the Block Protect (BP2, BP1, BP0), INV and CMP bits, are also hardware protected against data modification if WP# is Low during a SET FEATURES command.

The WP# function is replaced by DQ2 for input and output during Quad mode for receiving addresses, and data to be programmed (values are latched on rising edge of the CLK signal) as well as shifting out data (on the falling edge of CLK).

7.7. Hold (HOLD#) / DQ3

For Standard SPI and Dual SPI operations, the HOLD# signal allows the FM25LG02A operation to be paused while it is actively selected (when CS# is low). The HOLD# function may be useful in cases where the SPI data and clock signals are shared with other devices. For example, consider if the page buffer was only partially written when a priority interrupt requires use of the SPI bus. In this case the HOLD# function can save the state of the instruction and the data in the buffer so programming can resume where it left off once the bus is available again.

To initiate a HOLD# condition, the device must be selected with CS# low. A HOLD# condition will activate on the falling edge of the HOLD# signal if the CLK signal is already low. If the CLK is not already low the HOLD# condition will activate after the next falling edge of CLK. The HOLD# condition will terminate on the rising edge of the HOLD# signal if the CLK signal is already low. If the CLK is not already low the HOLD# condition will terminate after the next falling edge of CLK. During a HOLD# condition, the Serial Output (DO) is high impedance, and Serial Input (DI) and Serial Clock (CLK) are ignored. The Chip Select (CS#) signal should be kept active (low) for the full duration of the HOLD# operation to avoid resetting the internal logic state of the device.

The HOLD# function is not available when the Quad mode is enabled (QE =1). The Hold function is replaced by DQ3 for input and output during Quad mode for receiving addresses, and data to be programmed (values are latched on rising edge of the CLK signal) as well as shifting out data (on the falling edge of CLK).

Figure 6 Hold Condition Waveform

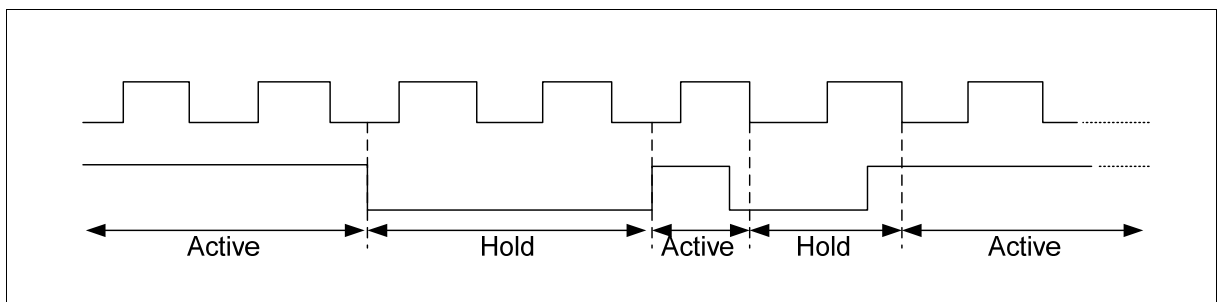

8. Command Definition

8.1. Command Set Tables

Table 3 Standard SPI Command Set

INSTRUCTION NAME	BYTE 1	BYTE 2	BYTE 3	BYTE 4	BYTE 5	BYTE N
WRITE ENABLE	06h					
WRITE DISABLE	04h					
GET FEATURES	0Fh	A7-A0	(D7-D0)			
SET FEATURES	1Fh	A7-A0	D7-D0			
PAGE READ	13h	A23-A16	A15-A8	A7-A0		
READ FROM CACHE	03h/0Bh	A15-A8 ⁽²⁾	A7-A0	dummy	(D7-D0)	wrap
READ ID	9Fh	dummy	(MID) ⁽⁸⁾	(DID) ⁽⁸⁾		wrap
READ UID	4Bh	dummy	dummy	dummy	dummy	(D7-D0)
PROGRAM LOAD	02h	A15-A8 ⁽⁶⁾	A7-A0	D7-D0	Next byte	Byte N
PROGRAM LOAD RANDOM DATA ⁽⁹⁾	84h	A15-A8 ⁽⁶⁾	A7-A0	D7-D0	Next byte	Byte N
PROGRAM EXECUTE	10h	A23-A16	A15-A8	A7-A0		
BLOCK ERASE	D8h	A23-A16	A15-A8	A7-A0		
RESET	FFh					
INDIVIDUAL BLOCK LOCK	36h	A23-A16	A15-A8	A7-A0	⁽¹⁰⁾	
INDIVIDUAL BLOCK UNLOCK	39h	A23-A16	A15-A8	A7-A0	⁽¹⁰⁾	
READ BLOCK LOCK	3Dh	A23-A16	A15-A8	A7-A0	(D7-D0)	⁽¹⁰⁾
GLOBAL BLOCK LOCK	7Eh					
GLOBAL BLOCK UNLOCK	98h					

Table 4 Dual SPI Command Set

INSTRUCTION NAME	BYTE 1	BYTE 2	BYTE 3	BYTE 4	BYTE 5	BYTE N
READ FROM CACHE x 2	3Bh	A15-A8 ⁽²⁾	A7-A0	dummy	(D7-D0)x2	wrap
READ FROM CACHE DUAL IO	BBh	A15-A0 ⁽³⁾	dummy ⁽⁴⁾	(D7-D0)x2		wrap

Table 5 Quad SPI Command Set

INSTRUCTION NAME	BYTE 1	BYTE 2	BYTE 3	BYTE 4	BYTE 5	BYTE N
READ FROM CACHE x4	6Bh	A15-A8 ⁽²⁾	A7-A0	dummy	(D7-D0)x4	wrap
READ FROM CACHE QUAD IO	EBh	A15-A0 ⁽⁵⁾	(D7-D0)x4			wrap
PROGRAM LOAD x4	32h	A15-A8 ⁽⁶⁾	A7-A0	(D7-D0)x4	Next byte	Byte N
PROGRAM LOAD RANDOM DATA x4 ⁽⁹⁾	C4h/34h	A15-A8 ⁽⁶⁾	A7-A0	(D7-D0)x4	Next byte	Byte N
PROGRAM LOAD RANDOM DATA Quad IO ⁽⁹⁾	72h	A15-A0 ⁽⁷⁾	(D7-D0)x4	Next byte		Byte N

Notes:

1. Data bytes are shifted with Most Significant Bit first. Byte fields with data in parenthesis “()” indicate data output from the device on either 1, 2 or 4 DQ pins.
2. The x8 clock = wrap<3:0>, A11-A8
3. The x8 clock = wrap<3:0>, A11-A0
4. The x8 clock = dummy<7:0>, D7-D0
5. The x8 clock = wrap<3:0>, A11-A0, dummy<7:0>, D7-D0

6. The x8 clock = dummy<3:0>, A11-A8
7. The x8 clock = dummy<3:0>, A11-A0, D7-D0, D7-D0
8. MID is Manufacture ID(A1h for FMSH), DID is Device ID(C2h for current device)
9. Only available in INTERNAL DATA MOVE operation
10. A<23>=0, A<22:12> is RA<16:6>, A<11:0> is dummy bits

8.2. WRITE operation

8.2.1. WRITE ENABLE (WREN) (06h)

The WRITE ENABLE (WREN) command sets the WEL bit in the status register to 1. The WEL bit must be set prior to following operations that changes the contents of the memory array:

- PAGE PROGRAM
- OTP PROGRAM
- OTP LOCK
- BLOCK ERASE

Figure 7 WRITE ENABLE (06h) Timing

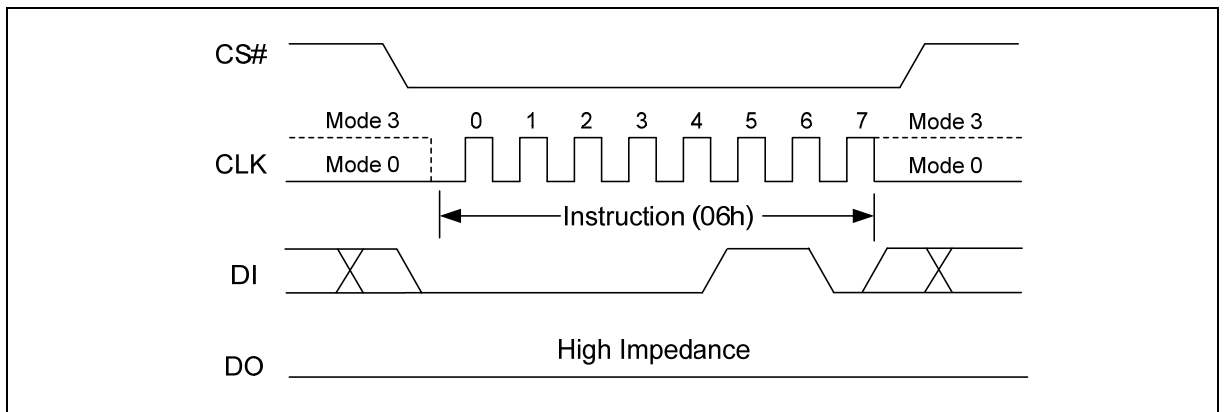

8.2.2. WRITE DISABLE (WRDI) (04h)

The WRITE DISABLE (WRDI) command resets the WEL bit in the status register to 0. The WEL bit is automatically reset after Power-up and upon completion of the following operations:

- PAGE PROGRAM
- OTP PROGRAM
- OTP LOCK
- BLOCK ERASE

Figure 8 WRITE DISABLE (04h) Timing

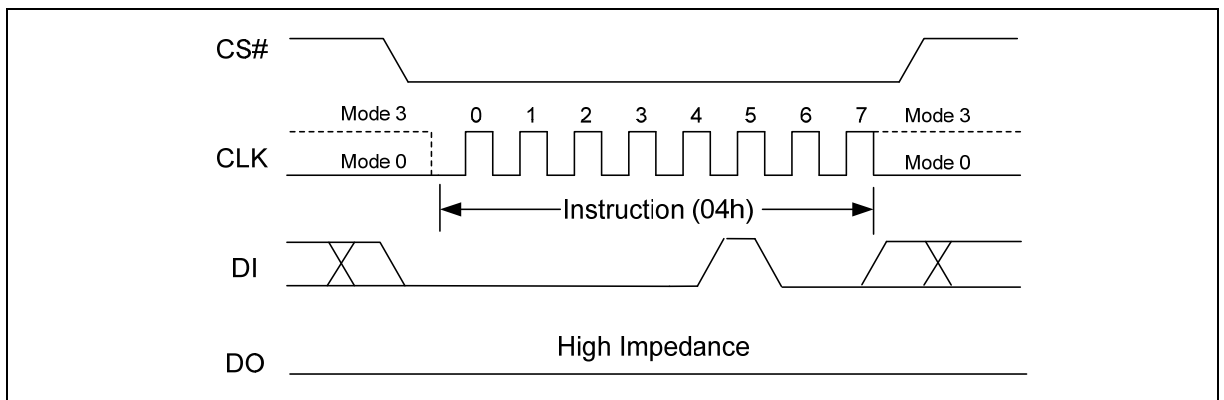

8.3. Feature Operation

8.3.1. GET FEATURES (0Fh) and SET FEATURES (1Fh)

The GET FEATURES (0Fh) and SET FEATURES (1Fh) commands are used to alter the device behavior from the default power-on behavior. These commands use a 1-byte feature address to determine which feature is to be read or modified. Features such as OTP and block locking can be enabled or disabled by setting specific bits in feature address A0h and B0h (shown the following table). The status register is mostly read, except WEL, which is writable bit with the WREN (06h) command.

When a feature is set, it remains active until the device is power cycled or the feature is written to. Unless otherwise specified in the following table, once the device is set, it remains set, even if a RESET (FFh) command is issued.

Table 6 Features Settings

Register	Address	Data Bits							
		7	6	5	4	3	2	1	0
Block Lock	A0h	BRWD	Reserved	BP2	BP1	BP0	INV	CMP	Reserved
Feature	B0h	OTP_PRT	OTP_EN	WPS	ECC_EN	Reserved	Reserved	Reserved	QE
Status	C0h	Reserved	Reserved	ECCS1	ECCS0	P_FAIL	E_FAIL	WEL	OIP

Notes:

1. If BRWD is enabled and WP# is low, then the block lock register (BP2-BP0, INV and CMP) cannot be changed.
2. If QE is enabled, the quad IO operations can be executed.
3. All the reserved bits must be held low when the feature is set.
4. The features in the feature byte B0H are all volatile except OTP_PRT bit.

Figure 9 GET FEATURES (0Fh) Timing

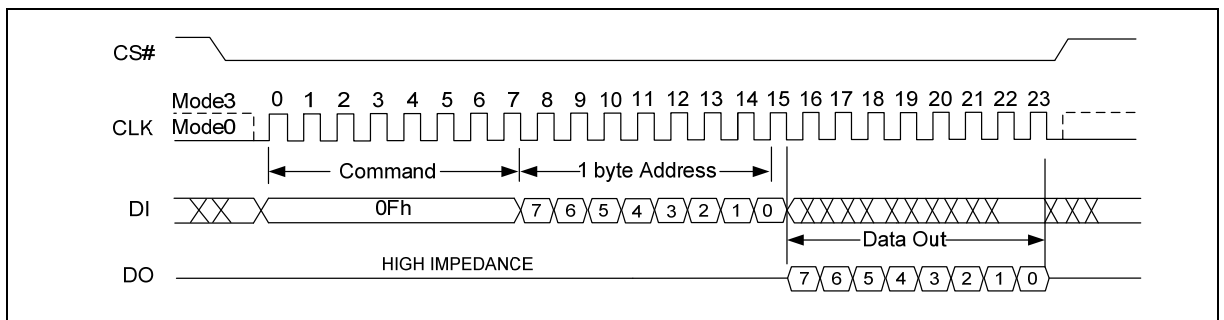
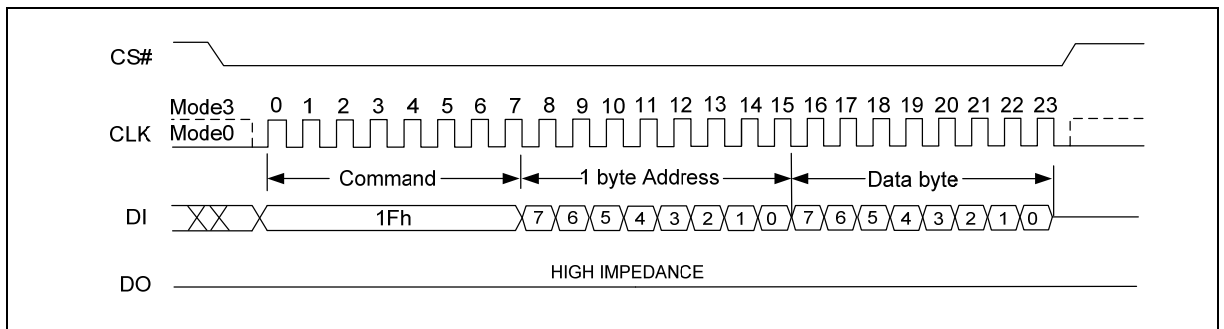

Figure 10 SET FEATURES (1Fh) Timing



8.4. READ Operation

8.4.1. PAGE READ

The PAGE READ (13h) command transfers the data from the NAND Flash array to the cache register. The command sequence is follows:

- 13h (PAGE READ TO CACHE)
- 0Fh (GET FEATURES command to read the status)
- 0Bh or 03h (READ FROM CACHE)
- READ FROM CACHE Operation
 - 3Bh (READ FROM CACHE x2)
 - 6Bh (READ FROM CACHE x4)
 - BBh (READ FROM CACHE DUAL IO)
 - EBh (READ FROM CACHE QUAD IO)

The PAGE READ command requires a 24-bit address consisting of 7 dummy bits followed by an 17-bit block/page address. After the block/page addresses are registered, the device starts the transfer from the main array to the cache register, and is busy for t_{RD} time. During this time, the GET FEATURE (0Fh) command can be issued to monitor the status of the operation (refer to the Status Register section). Following a status of successful completion, the READ FROM CACHE (03h/0Bh/3Bh/6Bh/BBh/EBh) command must be issued in order to read the data out of the cache.

The READ FROM CACHE command requires 4 wrap mode configure bits, followed by 12-bit column address for the starting byte address. The starting byte address must be in 0 to 2175. After the end of the cache register is reached, the data wraps around the beginning boundary automatically until CS# is pulled high to terminate this operation.

Table 7 Wrap Configure Bit Table

Wrap<3:0>	Wrap Length (byte)
00xx	2176
01xx	2048
10xx	64
11xx	16

8.4.1. PAGE READ TO CACHE (13h)

Figure 11 READ FROM CACHE (13h) Timing

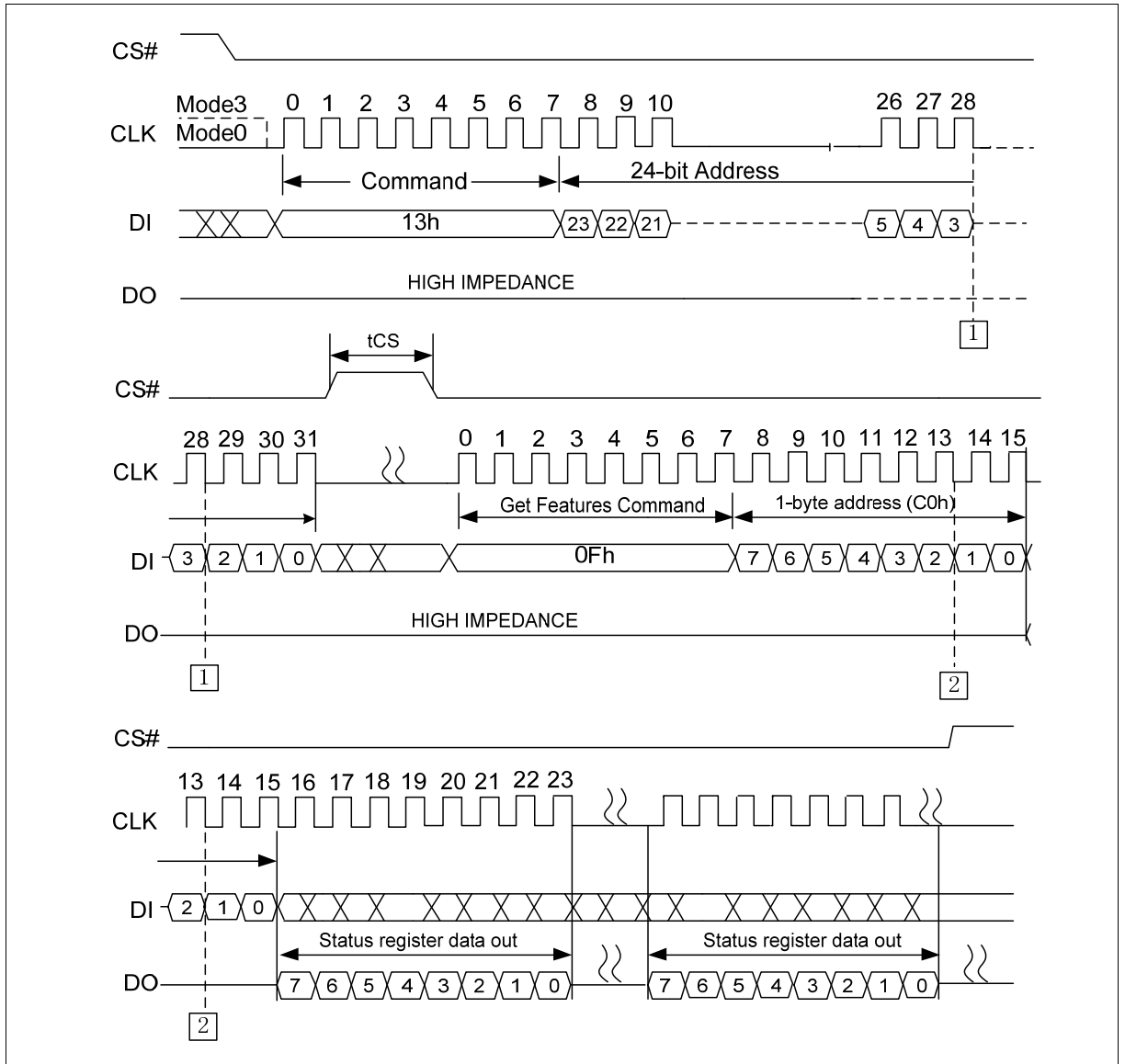

8.4.2. READ FROM CACHE (03h/0Bh)

Figure 12 READ FROM CACHE (03h / 0Bh) Timing

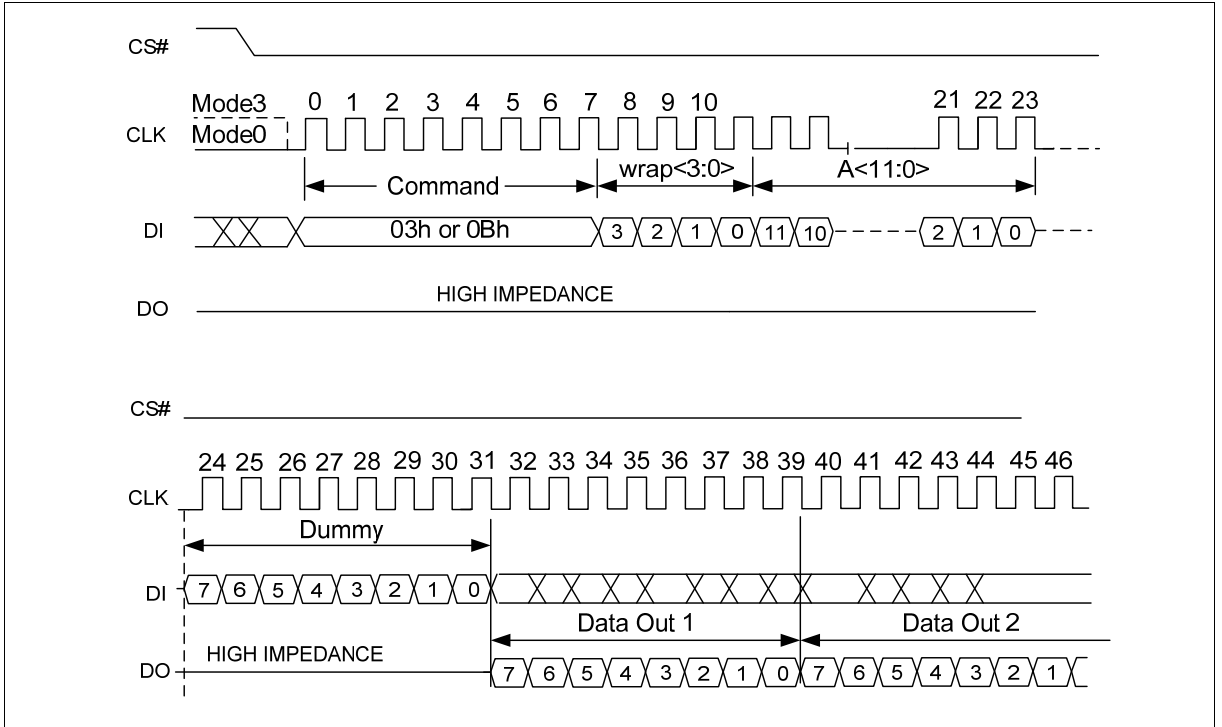

8.4.3. READ FROM CACHE x2 (3Bh)

Figure 13 READ FROM CACHE x2 (3Bh) Timing

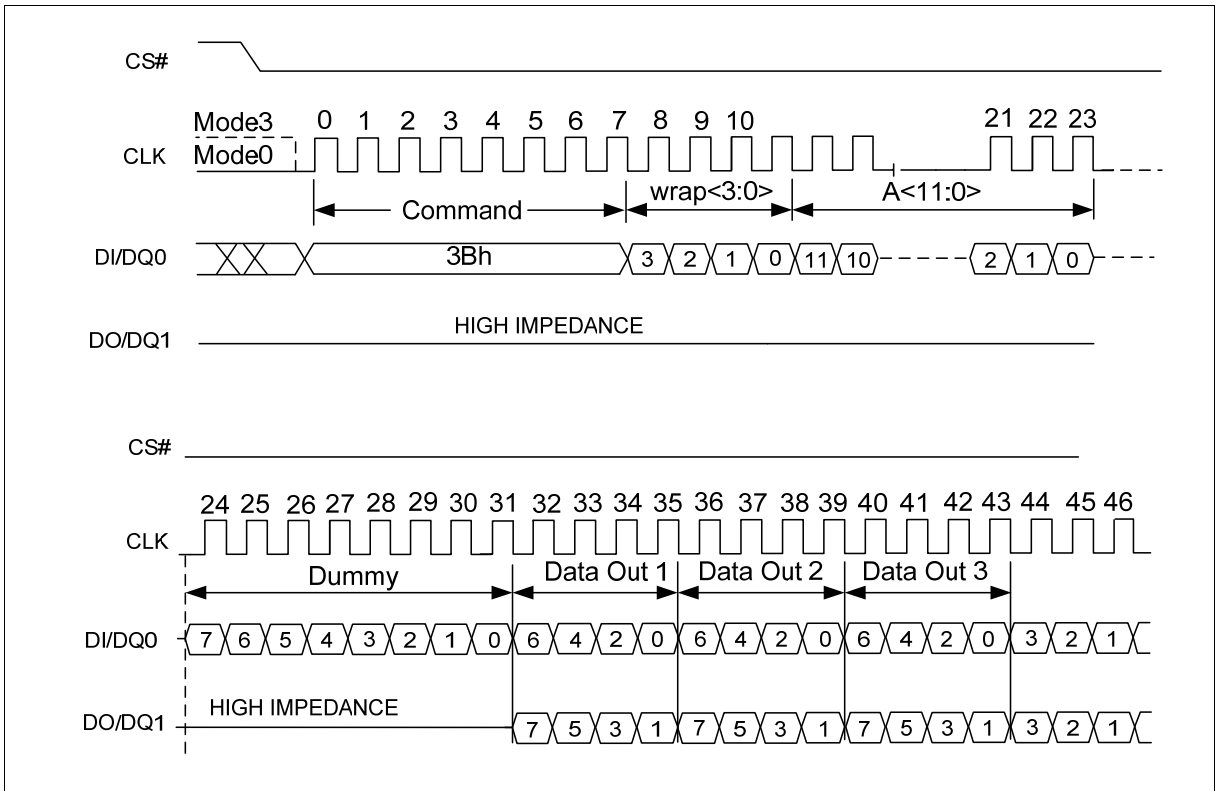

8.4.4. READ FROM CACHE x4 (6Bh)

The Quad Enable bit (QE) of feature (B0[0]) must be set to enable the READ FROM CACHE x4 command.

Figure 14 READ FROM CACHE x4 (6Bh) Timing

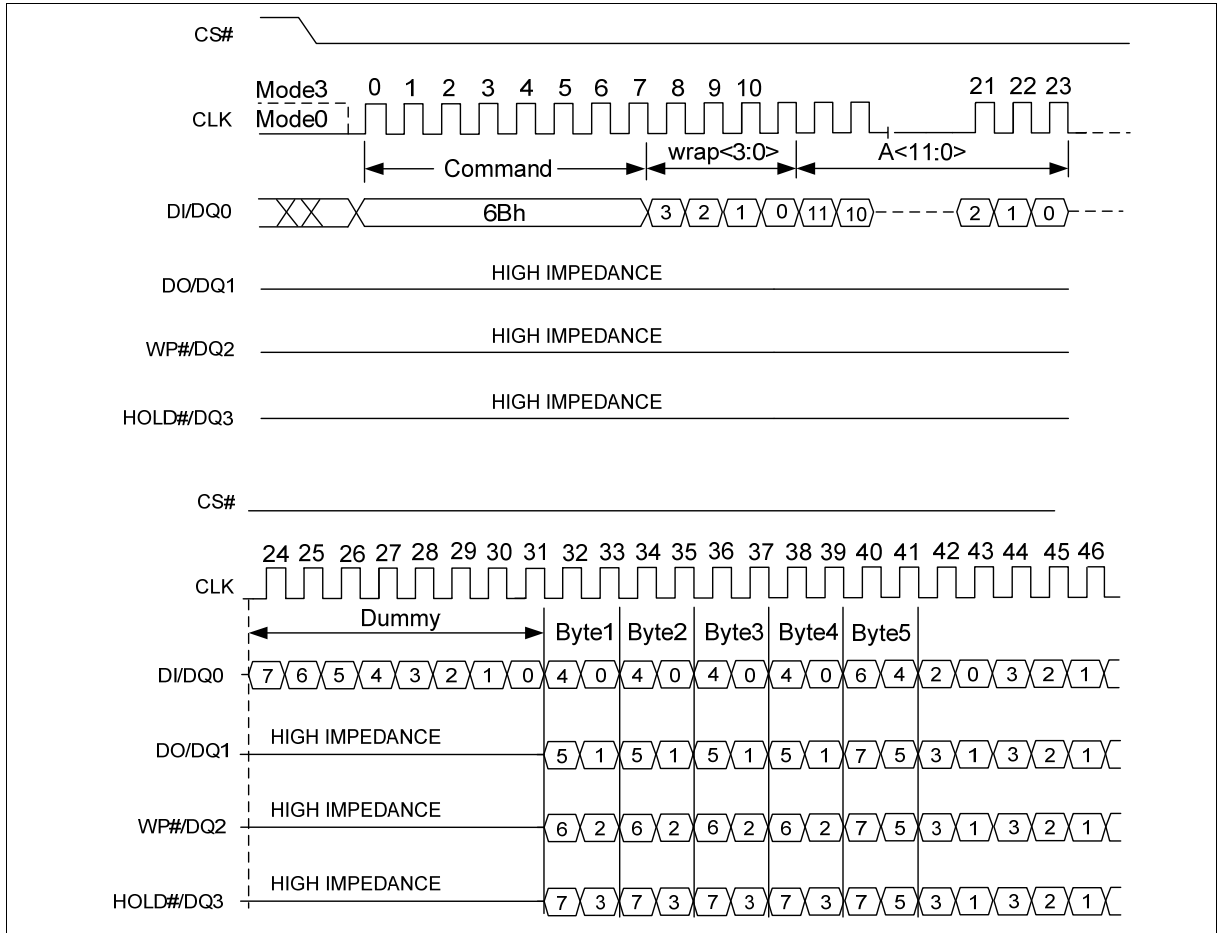

8.4.5. READ FROM CACHE DUAL IO (BBh)

The READ FROM CACHE DUAL IO command is similar to the READ FROM CACHE x2 command except that wrap bits, 12-bit column address and dummy bits are input through two pins DQ₀, DQ₁.

Figure 15 READ FROM CACHE DUAL IO (BBh) Timing

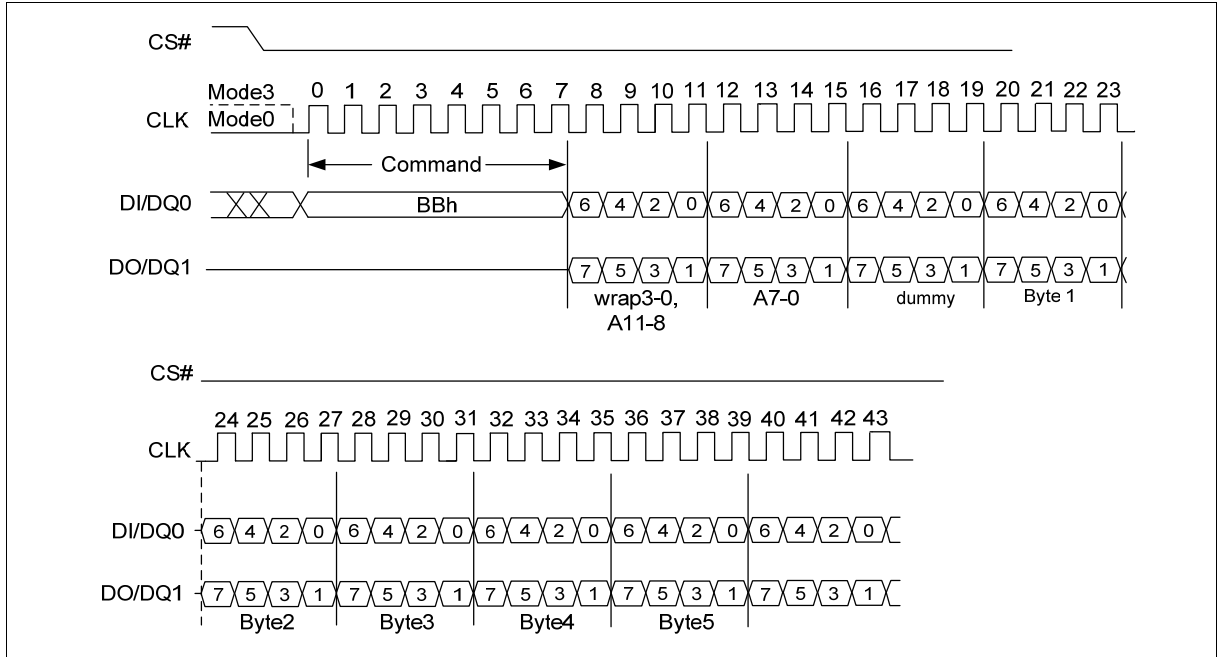

8.4.6. READ FROM CACHE QUAD IO (EBh)

The READ FROM CACHE QUAD IO command is similar to the READ FROM CACHE x4 command except that wrap bits, 12-bit column address and dummy bits are input through four pins DQ₀, DQ₁, DQ₂ and DQ₃.

The Quad Enable bit (QE) of feature (B0[0]) must be set to enable the READ FROM CACHE QUAD IO command.

Figure 16 READ FROM CACHE QUAD IO (EBh) Timing

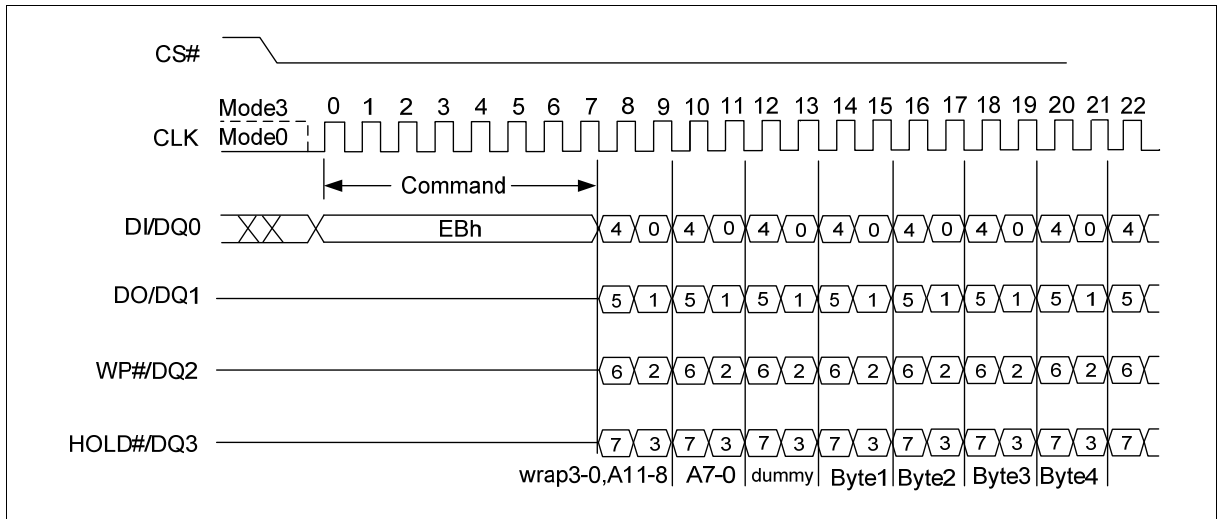

8.4.7. READ ID (9Fh)

The READ ID command is used to read the 2 bytes of identifier code programmed into the NAND Flash device. The READ ID command reads a 2-byte table (see below) that includes the Manufacturer ID and the device configuration.

Figure 17 READ ID (9Fh) Timing

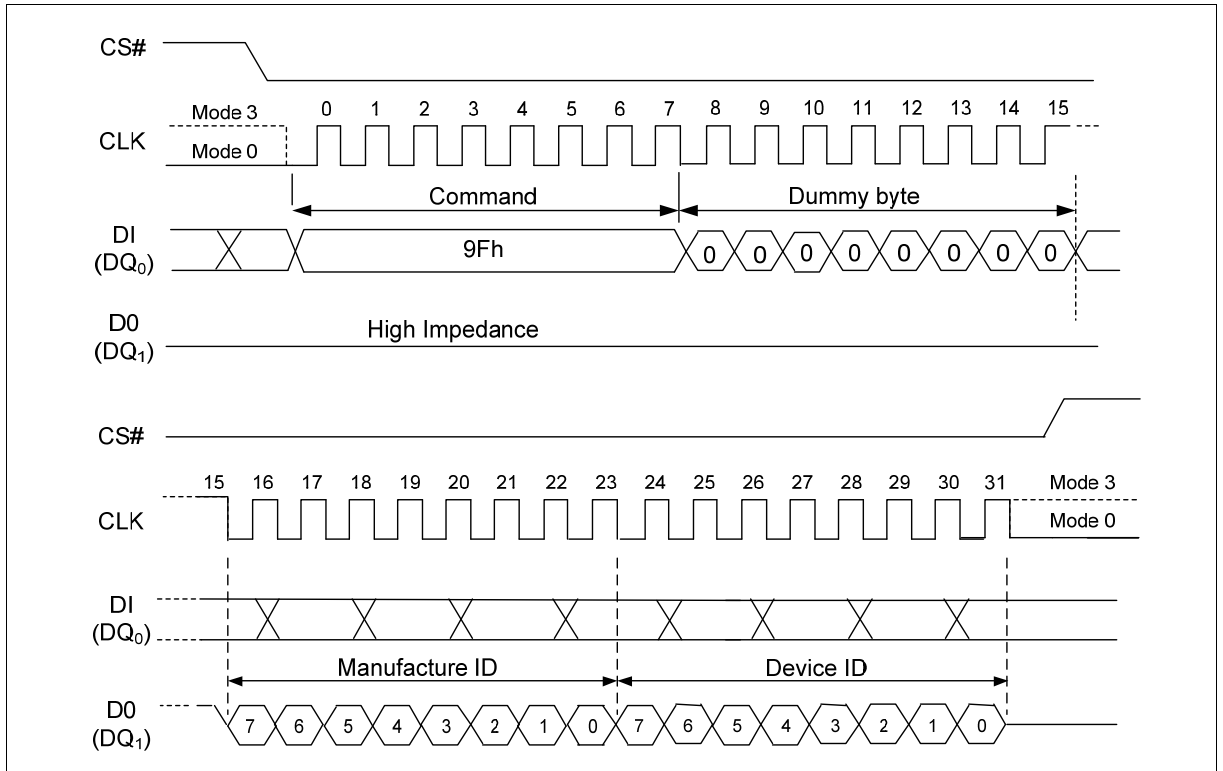

8.4.8. READ UID (4Bh)

The READ UID instruction accesses a factory-set read-only 64-bit number that is unique to each FM25LG02A device. The ID number can be used in conjunction with user software methods to help prevent copying or cloning of a system.

Figure 18 READ UID (4Bh) Timing

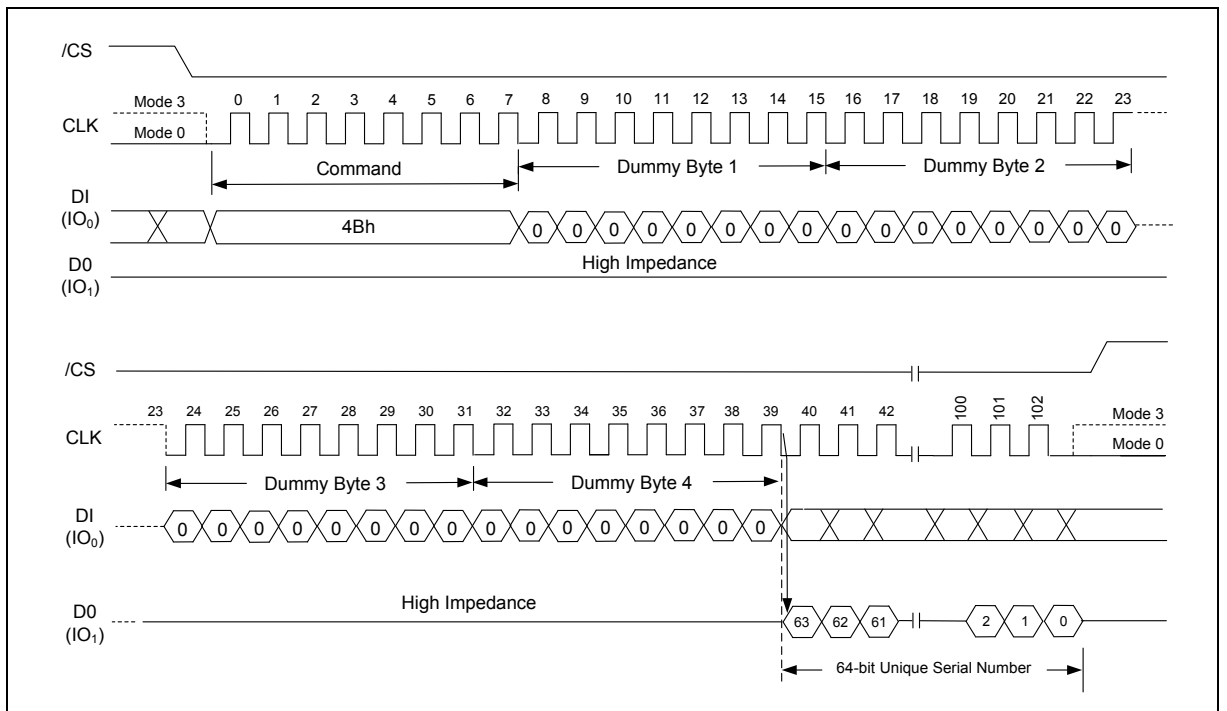

8.5. PROGRAM Operation

The PAGE PROGRAM operation sequence programs 1 byte to 2176 bytes of data within a page. The page program sequence is as follows:

- 02H (PROGRAM LOAD)/32H (PROGRAM LOAD x4)
- 06H (WRITE ENABLE)
- 10H (PROGRAM EXECUTE)
- 0FH (GET FEATURE command to read the status)

The 1st step is to issue a PROGRAM LOAD (02H/32H) command. PROGRAM LOAD consists of an 8-bit Op code, followed by 4 dummy bits and a 12-bit column address, then the data bytes to be programmed. The data bytes are loaded into a cache register which is 2176 bytes long. If more than 2176 bytes are loaded, then those additional bytes are ignored by the cache register. The command sequence ends when CS# goes from LOW to HIGH. Figure 19 shows the PROGRAM LOAD operation.

The 2nd step, prior to performing the PROGRAM EXECUTE operation, is to issue a WRITE ENABLE (06H) command. As with any command that changes the memory contents, the WRITE ENABLE must be executed in order to set the WEL bit. If this command is not issued, then the rest of the program sequence is ignored.

The 3rd step is to issue a PROGRAM EXECUTE (10h) command to initiate the transfer of data from the cache register to the main array. PROGRAM EXECUTE consists of an 8-bit Op code, followed by a 24-bit address (7 dummy bits and an 17-bit page/block address). After the page/block address is registered, the memory device starts the transfer from the cache register to the main array, and is busy for t_{PROG} time. This operation is shown in Figure 21.

During this busy time, the status register can be polled to monitor the status of the operation (refer to the Status Register section). When the operation completes successfully, the next series of data can be loaded with the PROGRAM LOAD command.

Note: The number of consecutive partial page programming operations (NOP) within the same page must not exceed 4. In addition, pages must be sequentially programmed within a block.

8.5.1. PROGRAM LOAD (02h)

Figure 19 PROGRAM LOAD (02h) Timing

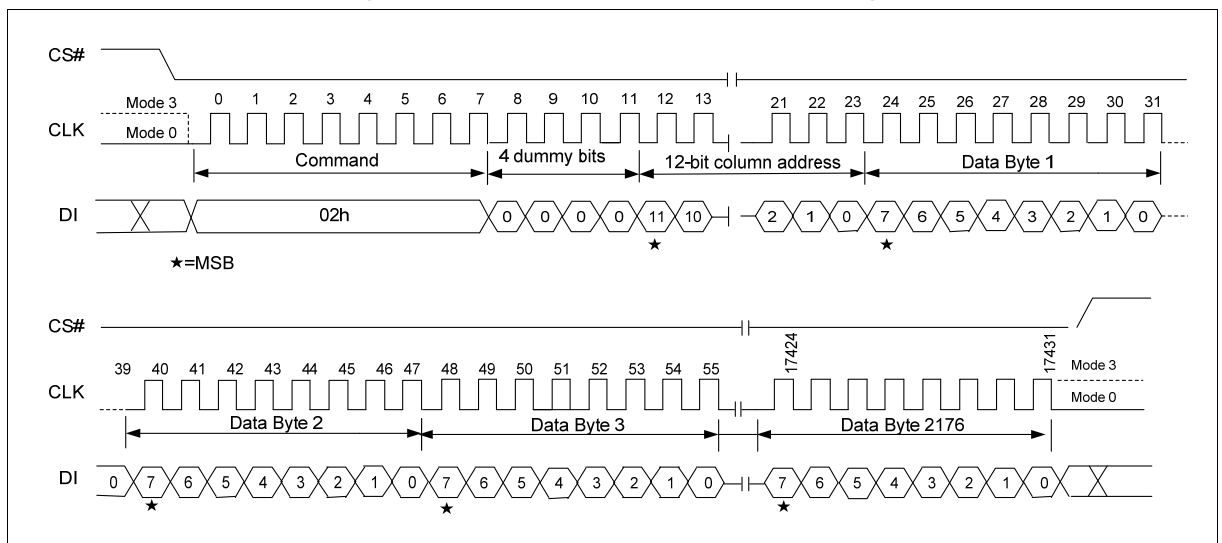

8.5.2. PROGRAM LOAD x4 (32h)

The PROGRAM LOAD x4 command (32H) is similar to the PROGRAM LOAD command (02H) but with the capability to input the data bytes by four pins: DQ0, DQ1, DQ2, and DQ3. The command sequence is shown below. The Quad Enable bit (QE) of feature (B0[0]) must be set to enable the PROGRAM LOAD x4 command.

Figure 20 PROGRAM LOAD x4 (32h) Timing

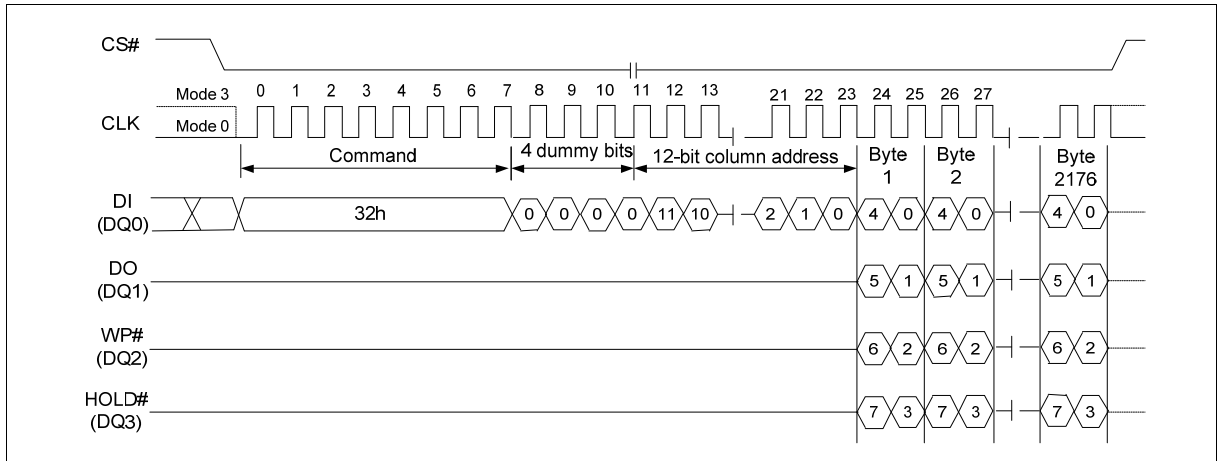

8.5.3. PROGRAM EXECUTE (PE) (10h)

Figure 21 PROGRAM EXECUTE (10h) Timing

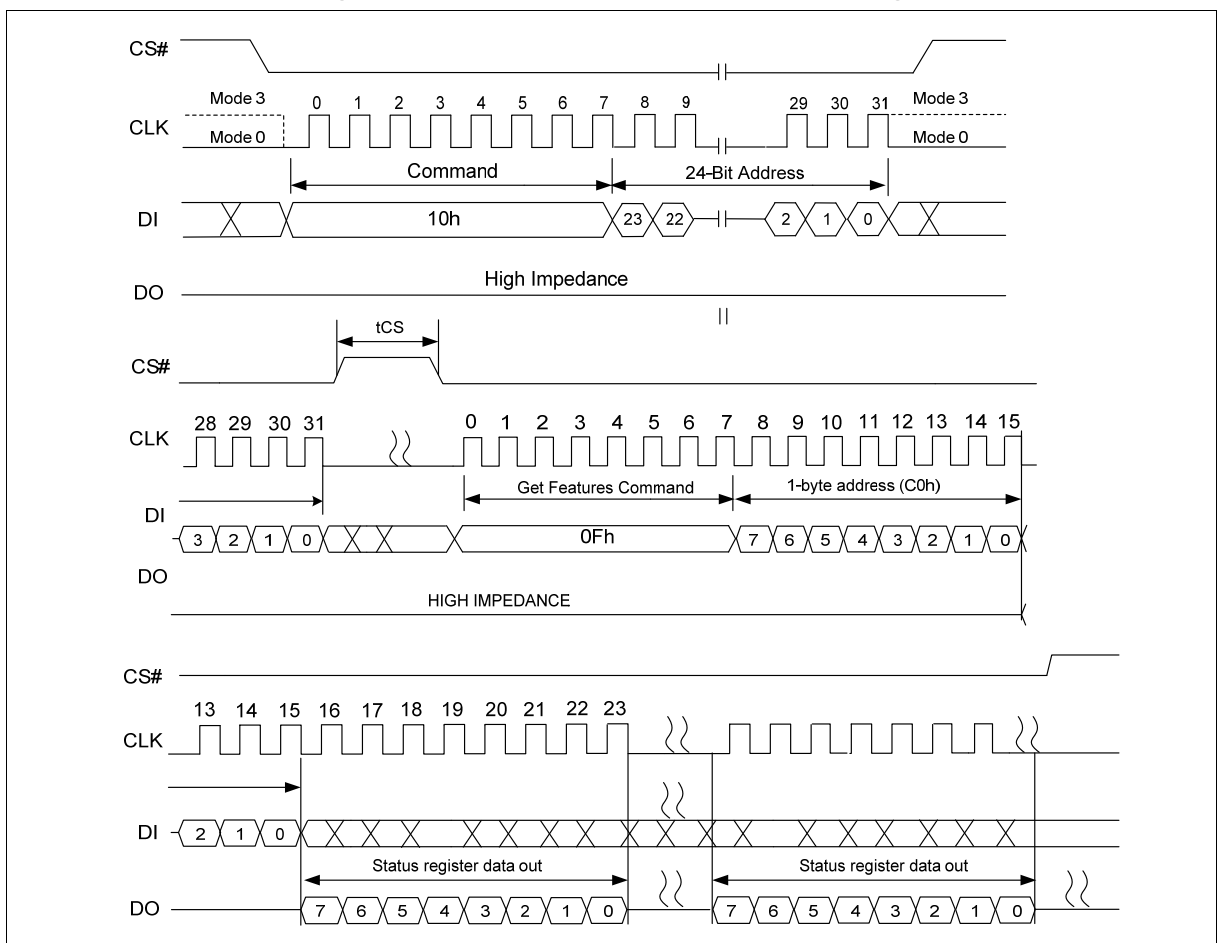

8.5.4. PROGRAM LOAD RANDOM DATA (84h)

Figure 22 PROGRAM LOAD RANDOM DATA (84h) Timing

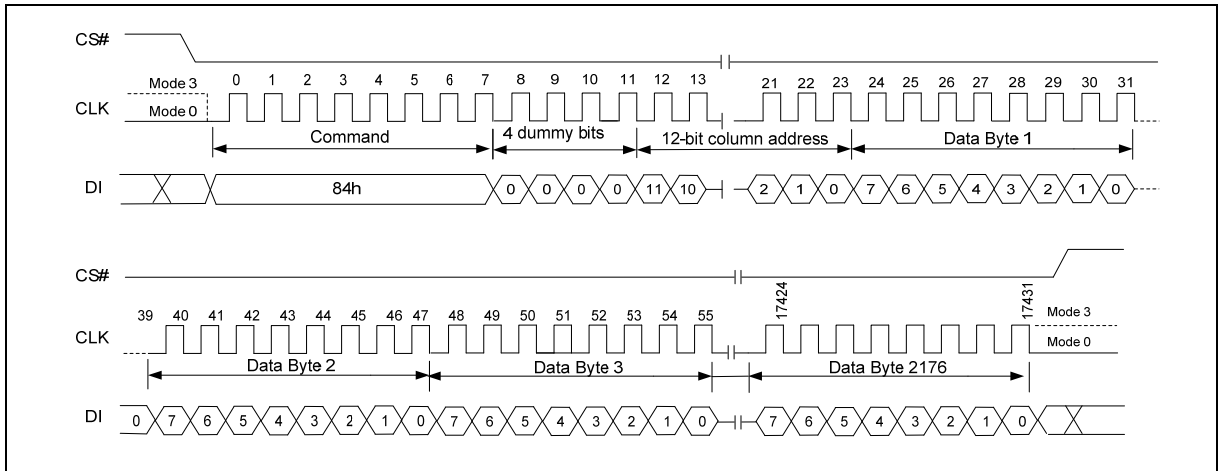

8.5.5. PROGRAM LOAD RANDOM DATA x4 (C4h/34h)

Figure 23 PROGRAM LOAD RANDOM DATA x4 (C4h/34h) Timing

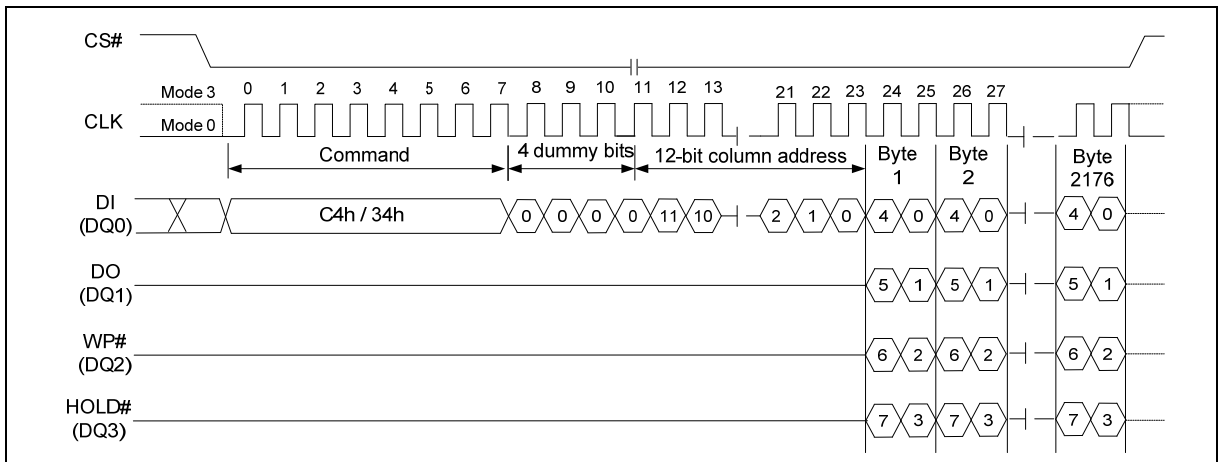

8.5.6. PROGRAM LOAD RANDOM DATA Quad IO (72h)

Figure 24 PROGRAM LOAD RANDOM DATA Quad IO (72h) Timing

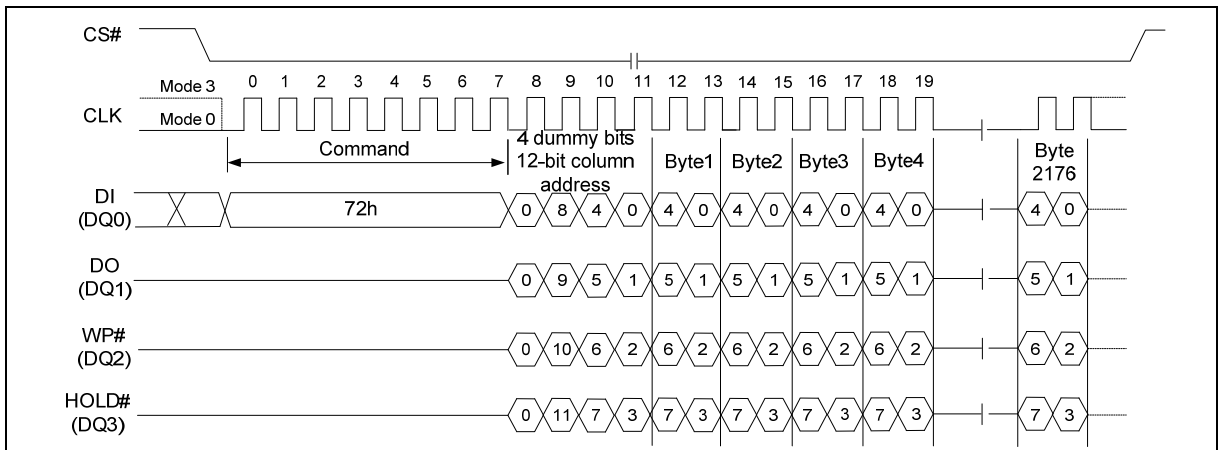

8.5.7. INTERNAL DATE MOVE

The INTERNAL DATA MOVE command sequence programs or replaces data in a page with existing data. The INTERNAL DATA MOVE command sequence is as follows:

- 13H (PAGE READ TO CACHE)
- 84H/C4H/34H/72H (PROGRAM LOAD RANDOM DATA : Optional)
- 06H (WRITE ENABLE)
- 10H (PROGRAM EXECUTE)
- 0FH (GET FEATURE command to read the status)

Prior to performing an INTERNAL DATA MOVE operation, the target page content must be read out into the cache register by issuing a PAGE READ (13H) command. The PROGRAM LOAD RANDOM DATA (84H/C4H/34H/72H) command can be issued, if user wants to update bytes of data in the page. This command consists of an 8-bit Op code, followed by 4 dummy bits and a 12-bit column address. New data is loaded in the 12-bit column address. If the RANDOM DATA is not sequential, another PROGRAM LOAD RANDOM DATA (84H/C4H/34H/72H) command must be issued with the new column address. After the data is loaded, the WRITE ENABLE command must be issued, then a PROGRAM EXECUTE (10H) command can be issued to start the programming operation.

8.6. ERASE Operation

8.6.1. BLOCK ERASE (D8h)

The BLOCK ERASE (D8h) command is used to erase at the block level. The blocks are organized as 64 pages per block, 2176 bytes per page (2048 + 128 bytes). Each block is 136 Kbytes. The BLOCK ERASE command (D8h) operates on one block at a time. The command sequence for the BLOCK ERASE operation is as follows:

- 06h (WRITE ENBALE command)
- D8h (BLOCK ERASE command)
- 0Fh (GET FEATURES command to read the status register)

Prior to performing the BLOCK ERASE operation, a WRITE ENABLE (06h) command must be issued. As with any command that changes the memory contents, the WRITE ENABLE command must be executed in order to set the WEL bit. If the WRITE ENABLE command is not issued, then the rest of the erase sequence is ignored. A WRITE ENABLE command must be followed by a BLOCK ERASE (D8h) command. This command requires a 24-bit address consisting of 7 dummy bits followed by a 17-bit row address. After the row address is registered, the control logic automatically controls timing and erase-verify operations. The device is busy for t_{ERS} time during the BLOCK ERASE operation. The GET FEATURES (0Fh) command can be used to monitor the status of the operation (refer to the Status Register section).

Figure 25 BLOCK ERASE (D8h) Timing

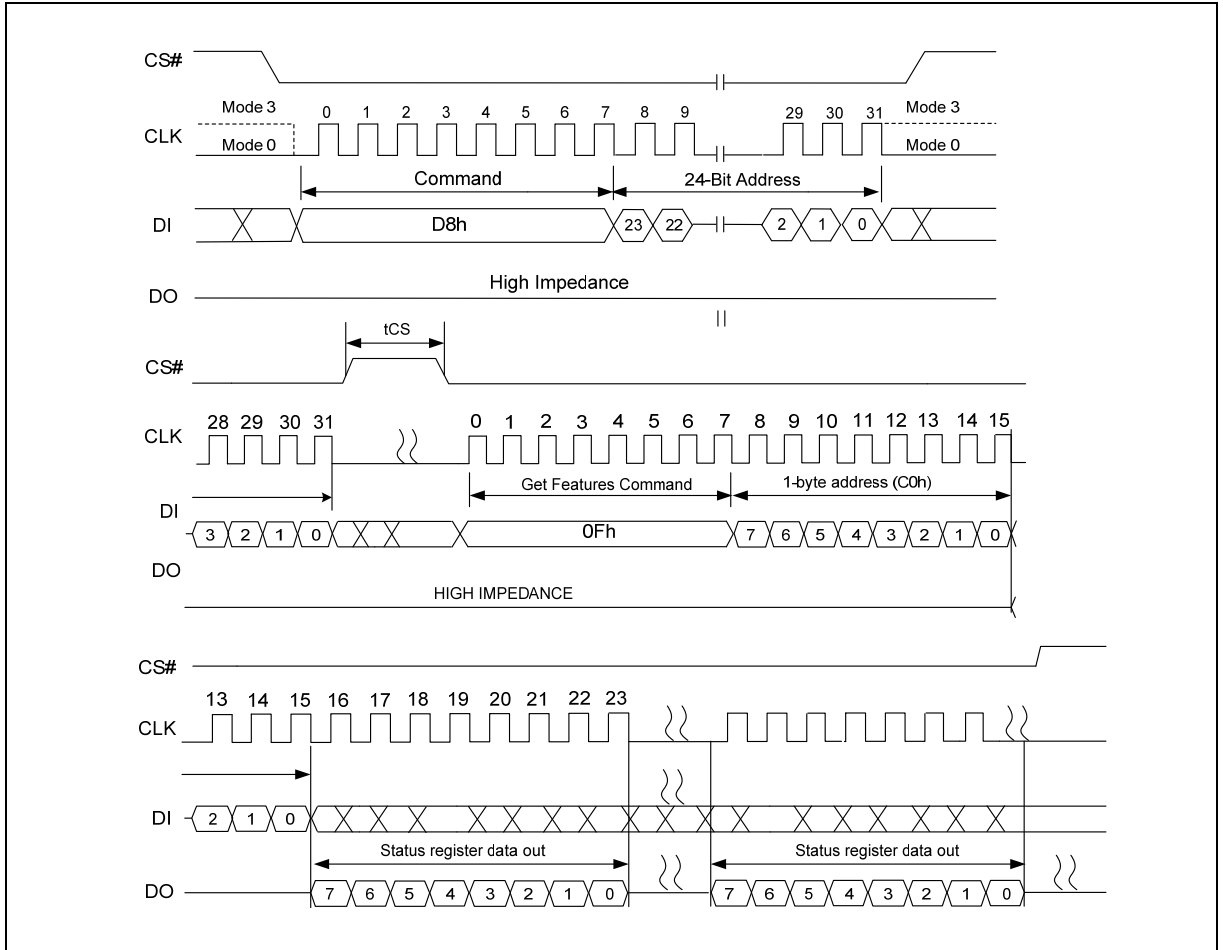

8.7. RESET Operation

The RESET (FFh) command stops all operations. For example, in case of a program or erase or read operation, the reset command can make the device enter the wait state.

8.7.1. RESET (FFh)

Figure 26 RESET (FFh) Timing

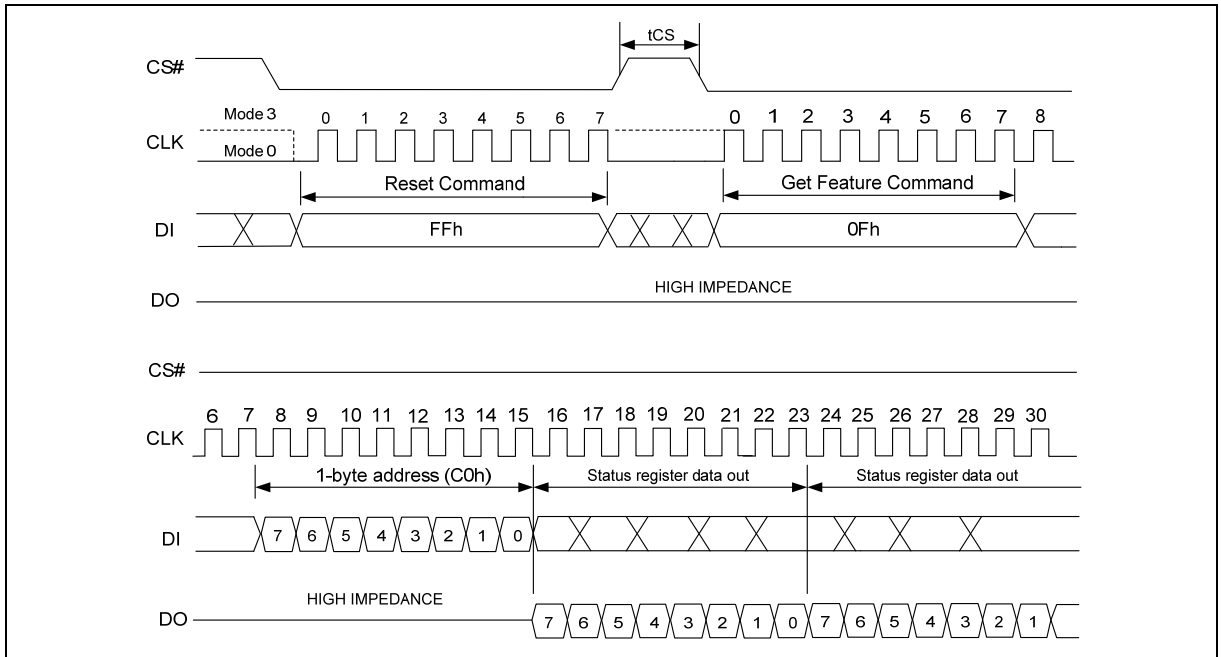

8.8. Write Protection

The WPS feature (B0[5]) is used to select block protection method.

If WPS=0, the write protection will be determined by the combination of CMP, INV, BP[2:0] bits in the Block Lock Register (A0h).

Table 8 Block Lock Register Block Protect Bits (WPS=0)

CMP	INV	BP2	BP1	BP0	Protected Row Address	Protected Rows
x	x	0	0	0	None	None
0	0	0	0	1	1F800h ~ 1FFFFh	Upper 1/64
0	0	0	1	0	1F000h ~ 1FFFFh	Upper 1/32
0	0	0	1	1	1E000h ~ 1FFFFh	Upper 1/16
0	0	1	0	0	1C000h ~ 1FFFFh	Upper 1/8
0	0	1	0	1	18000h ~ 1FFFFh	Upper 1/4
0	0	1	1	0	10000h ~ 1FFFFh	Upper 1/2
x	x	1	1	1	All (default)	All (default)
0	1	0	0	1	00000h ~ 007FFh	Lower 1/64
0	1	0	1	0	00000h ~ 00FFFh	Lower 1/32
0	1	0	1	1	00000h ~ 01FFFh	Lower 1/16
0	1	1	0	0	00000h ~ 03FFFh	Lower 1/8
0	1	1	0	1	00000h ~ 07FFFh	Lower 1/4
0	1	1	1	0	00000h ~ 0FFFFh	Lower 1/2
1	0	0	0	1	00000h ~ 1F7FFh	Lower 63/64
1	0	0	1	0	00000h ~ 1EFFFh	Lower 31/32
1	0	0	1	1	00000h ~ 1DFFFh	Lower 15/16
1	0	1	0	0	00000h ~ 1BFFFh	Lower 7/8

CMP	INV	BP2	BP1	BP0	Protected Row Address	Protected Rows
1	0	1	0	1	00000h ~ 17FFFh	Lower 3/4
1	0	1	1	0	00000h ~ 00003Fh	Block0
1	1	0	0	1	00800h ~ 1FFFFh	Upper 63/64
1	1	0	1	0	01000h ~ 1FFFFh	Upper 31/32
1	1	0	1	1	02000h ~ 1FFFFh	Upper 15/16
1	1	1	0	0	04000h ~ 1FFFFh	Upper 7/8
1	1	1	0	1	08000h ~ 1FFFFh	Upper 3/4
1	1	1	1	0	00000h ~ 00003Fh	Block0

If WPS=1, the INDIVIDUAL BLOCK LOCK is enabled. The INDIVIDUAL BLOCK LOCK provides an alternative way to protect the memory array from adverse Erase/Program. The INDIVIDUAL BLOCK LOCK bits are volatile bits. The default values after power up or after Reset are 1, so the entire memory array is being protected.

8.8.1. INDIVIDUAL BLOCK LOCK (36h)

The INDIVIDUAL BLOCK LOCK command requires a 24-bit address consisting of 1-bit '0' followed by a 11-bit block address (RA<5:0> is don't care) and 12 dummy bits. After the addresses are registered, the device starts setting the corresponding INDIVIDUAL BLOCK LOCK bit, and is busy for t_{LCK} time. During this time, the GET FEATURE (0Fh) command can be issued to monitor the status of the operation.

Figure 27 INDIVIDUAL BLOCK LOCK Command (36h) Timing

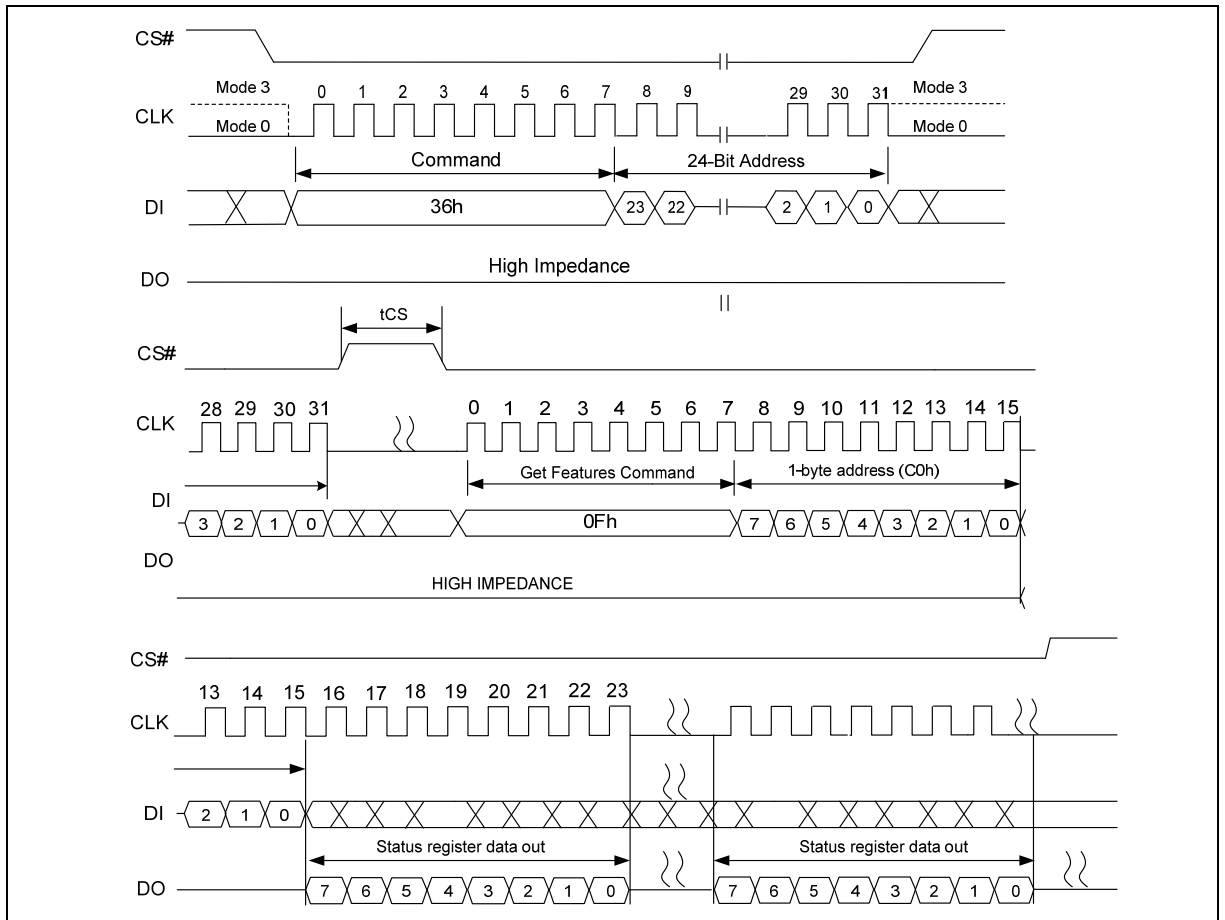

8.8.2. INDIVIDUAL BLOCK UNLOCK (39h)

The INDIVIDUAL BLOCK UNLOCK command requires a 24-bit address consisting of 1-bit '0' followed by a 11-bit block address (RA<5:0> is don't care) and 12 dummy bits. After the addresses are registered, the device starts clearing the corresponding INDIVIDUAL BLOCK LOCK bit, and is busy for t_{LCK} time. During this time, the GET FEATURE (0Fh) command can be issued to monitor the status of the operation.

Figure 28 INDIVIDUAL BLOCK UNLOCK Command (39h) Timing

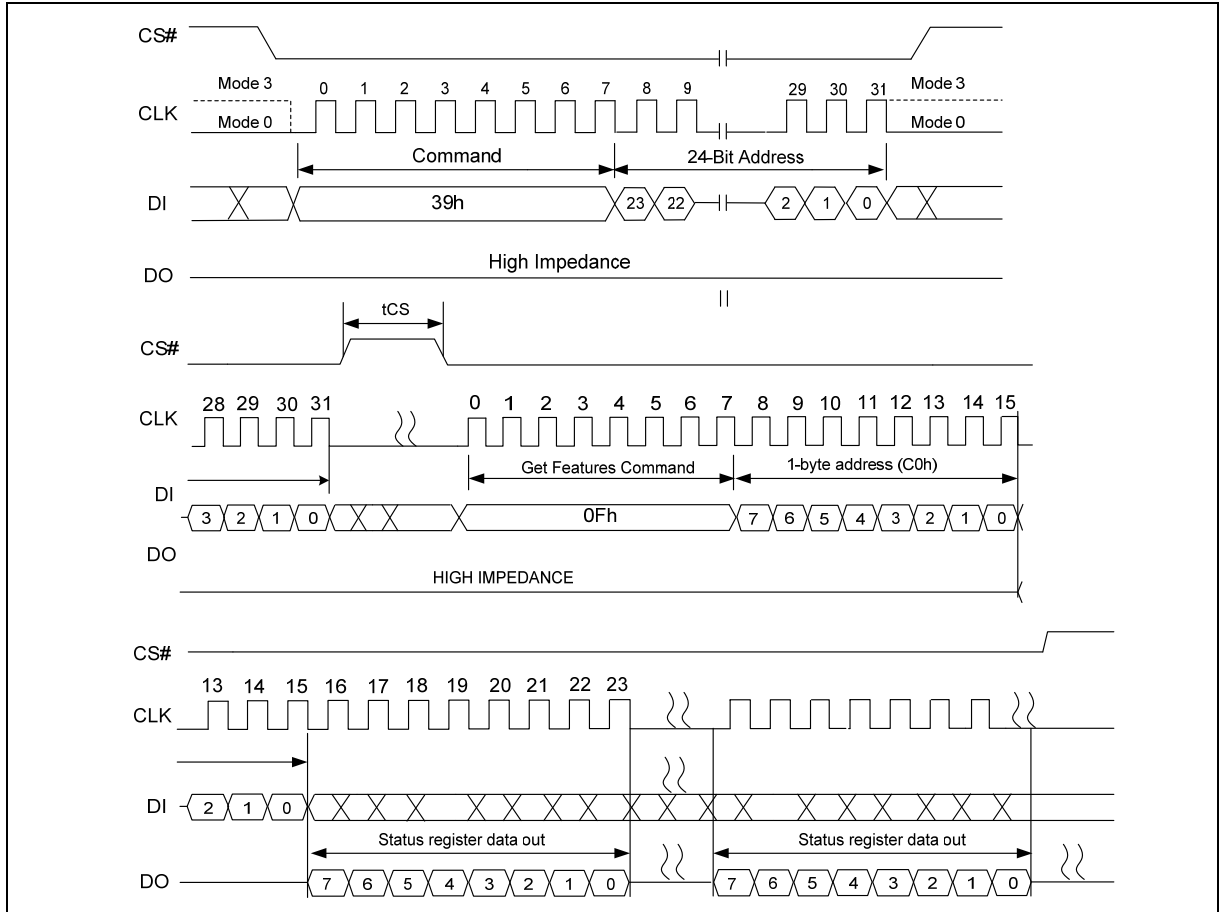

8.8.3. READ BLOCK LOCK (3Dh)

The READ BLOCK LOCK command can be used to read out the lock bit of a specific block. The READ BLOCK LOCK command requires a 24-bit address consisting of 1-bit '0' followed by a 11-bit block address (RA<5:0> is don't care) and 12 dummy bits. The Block Lock bit value will be shifted out on the DO pin at the falling edge of CLK shown in Figure 29. If the least significant bit (LSB) is 1, the corresponding block is locked; if LSB=0, the corresponding block is unlocked, ERASE/PROGRAM operation can be performed.

Figure 29 READ BLOCK LOCK Command (3Dh) Timing

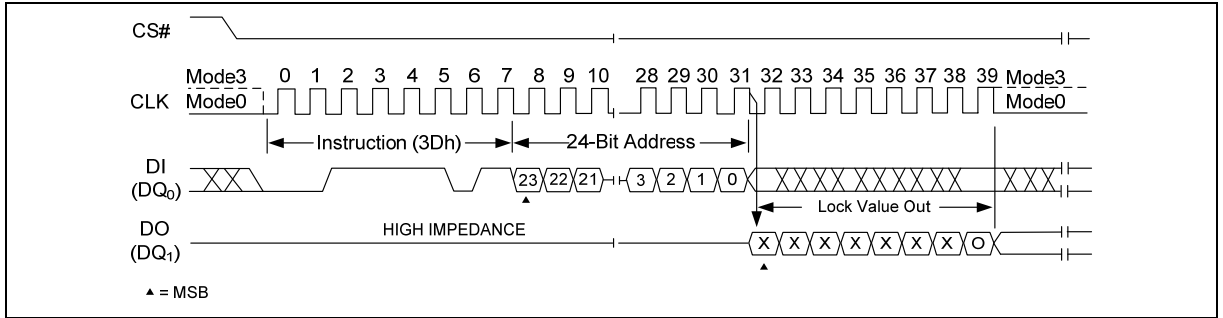

8.8.4. GLOBAL BLOCK LOCK (7Eh)

All Block Lock bits can be set to 1 by the GLOBAL BLOCK LOCK instruction. After CS# being driven high as shown in Figure 30, the device starts setting all the INDIVIDUAL BLOCK LOCK bits, and is busy for t_{LCK} time. During this time, the GET FEATURE (0Fh) command can be issued to monitor the status of the operation.

Figure 30 GLOBAL BLOCK LOCK Command (7Eh) Timing

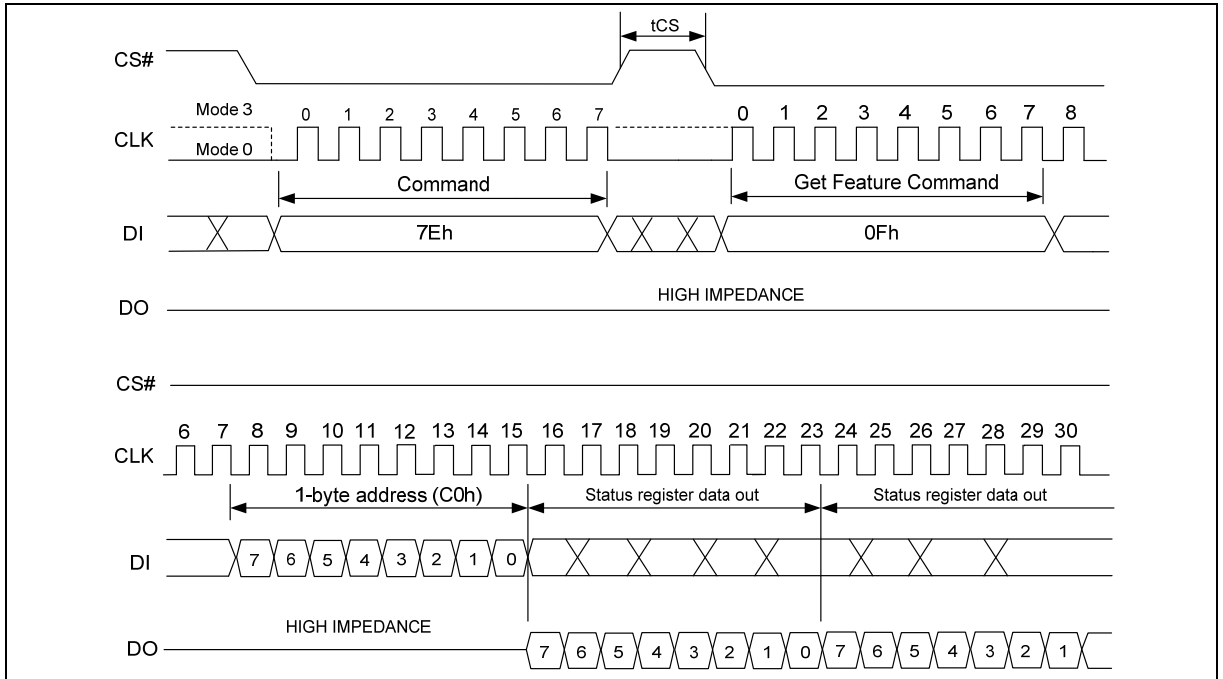

8.8.5. GLOBAL BLOCK UNLOCK (98h)

All Block Lock bits can be cleared to 0 by the GLOBAL BLOCK UNLOCK instruction. After CS# being driven high as shown in Figure 31, the device starts clearing all the INDIVIDUAL BLOCK LOCK bits, and is busy for t_{LCK} time. During this time, the GET FEATURE (0Fh) command can be issued to monitor the status of the operation.

Figure 31 GLOBAL BLOCK UNLOCK Command (98h) Timing

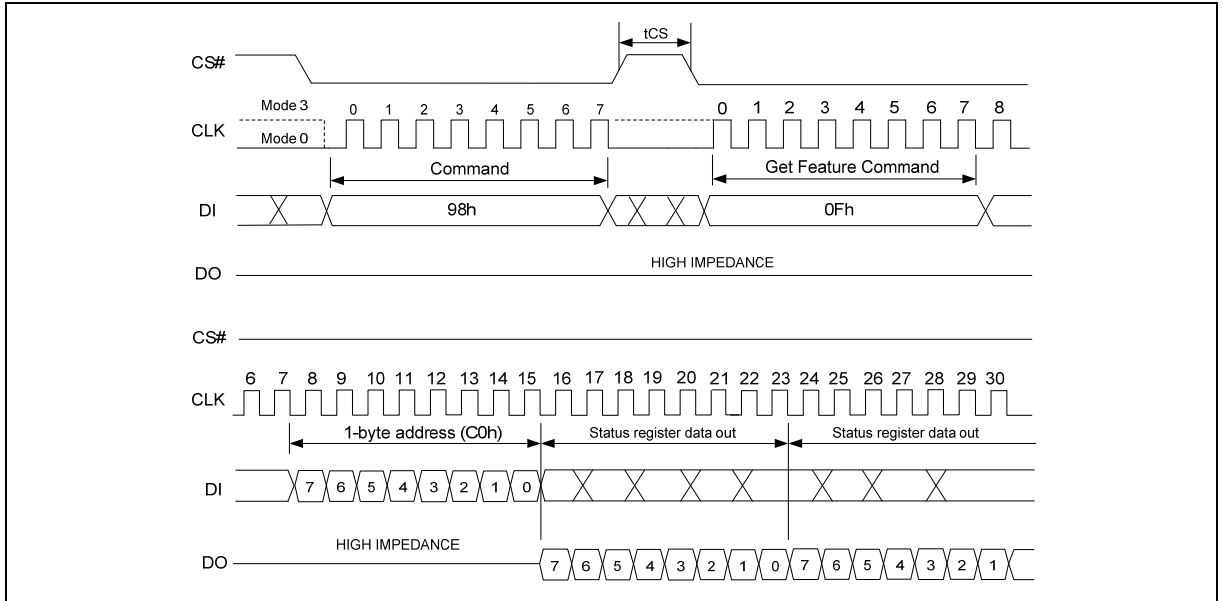

9. Status Register

The device has an 8-bit status register that software can read during the device operation for operation state query. The status register can be read by issuing the GET FEATURES (0FH) command, followed by the feature address C0h (see Feature Operation).

Table 9 Status Register Bit Description

Bit	Bit Name	Description
P_FAIL	Program Fail	This bit indicates that a program failure has occurred (P_FAIL set to 1). It will also be set if the user attempts to program an invalid address or a protected region, including the OTP area. This bit is cleared (P_FAIL = 0) during the PROGRAM EXECUTE command sequence or a RESET command.
E_FAIL	Erase Fail	This bit indicates that an erase failure has occurred (E_FAIL set to 1). It will also be set if the user attempts to erase a locked region. This bit is cleared (E_FAIL = 0) at the start of the BLOCK ERASE command sequence or the RESET command.
WEL	WRITE ENABLE Latch	This bit indicates the current status of the WRITE ENABLE latch (WEL) and must be set (WEL = 1), prior to issuing a PROGRAM EXECUTE or BLOCK ERASE command. It is set by issuing the WRITE ENABLE command. WEL can also be disabled (WEL = 0) by issuing the WRITE DISABLE command.
OIP	Operation In Progress	This bit indicates that PROGRAM EXECUTE, PAGE READ, BLOCK ERASE, RESET, GLOBAL BLOCK LOCK / UNLOCK or INDIVIDUAL BLOCK LOCK / UNLOCK is in progress.
ECCS1 ECCS0	ECC Status	ECCS provides ECC status as follows: 00b = No bit errors were detected during the previous read algorithm. 01b = bit error was detected and corrected, error bit number = 1~7. 10b = bit error was detected and not corrected. 11b = bit error was detected and corrected, error bit number = 8. ECCS is set to 00b either following a RESET, or at the beginning of the READ. It is then updated after the device completes a valid READ operation. ECCS is invalid if internal ECC is disabled (via a SET FEATURES command to reset ECC_EN).

10. OTP Region

The device offers a protected, One-Time Programmable NAND Flash memory area. Eight full pages (2176 bytes per page) are available on the device, and the entire range is guaranteed to be good. Customers can use the OTP area any way they want, like programming serial numbers, or other data, for permanent storage. When delivered from factory, feature bit OTP_PRT is 0.

To access the OTP feature, the user must issue the SET FEATURES command, followed by feature address B0h. When the OTP is ready for access, pages 00h–07h can be programmed in sequential order. The PROGRAM LOAD (02H) and PROGRAM EXECUTE (10H) commands can be used to program the pages. Also, the PAGE READ (13H) command and READ FROM CACHE (03h/0Bh/3Bh/6Bh/BBh/EBh) commands can be used to read the OTP area. The data bits used in feature address B0h to enable OTP access are shown in the table below.

OTP Access

To access OTP, perform the following command sequence:

- Issue the SET FEATURES command (1Fh) to set OTP_EN
- Issue the PAGE PROGRAM (if OTP_EN=1) or PAGE READ command

It is important to note that after bits 6 and 7 of the OTP register are set by the user, the OTP area becomes read-only and no further programming is supported. For OTP states, see the following table.

OTP Protect

- Issue the SET FEATURES command (1FH) to set OTP_EN and OTP_PRT
- 06H (WRITE ENABLE)
- Issue the PROGRAM EXECUTE (10H) command

Table 10 OTP States

OTP_PRT	OTP_EN	State
x	0	Normal Operation
0	1	Access OTP region
1	1	1. When the device power on state OTP_PRT is 0, user can set feature bit OTP_PRT and OTP_EN to 1, then issue PROGRAM EXECUTE (10H) to lock OTP, and after that OTP_PRT will permanently remain 1. 2. When the device power on state OTP_PRT is 1, user can only read the OTP region data.

11. Error Management

This NAND Flash device is specified to have the minimum number of valid blocks (N_{VB}) of the total available blocks per die shown in the table below. This means the devices may have blocks that are invalid when shipped from the factory. An invalid block is one that contains at least one page that has more bad bits than can be corrected by the minimum required ECC. Additional bad blocks may develop with use. However, the total number of available blocks will not fall below N_{VB} during the endurance life of the product.

Although NAND Flash memory devices may contain bad blocks, they can be used reliably in systems that provide bad-block management and error-correction algorithms. This ensures data integrity.

Internal circuitry isolates each block from other blocks, so the presence of a bad block does not affect the operation of the rest of the NAND Flash array.

NAND Flash devices are shipped from the factory erased. The factory identifies invalid blocks before shipping by attempting to program the bad-block mark into every location in the first page of each invalid block. It may not be possible to program every location in an invalid block with the bad-block mark. However, the first spare area location in each bad block is guaranteed to contain the bad-block mark. This method is compliant with ONFI factory defect mapping requirements. See the following table for the bad-block mark.

System software should initially check the first spare area location for non-FFh data on the first page of each block prior to performing any program or erase operations on the NAND Flash device. A bad-block table can then be created, enabling system software to map around these areas. Factory testing is performed under worst-case conditions. Because invalid blocks may be marginal, it may not be possible to recover the bad-block marking if the block is erased.

Table 11 Error Management Details

Description	Requirement
Minimum number of valid blocks (N_{VB})	2007
Total available blocks per die	2048
First spare area location	Byte 2048
Bad-block mark	Non FFh

12. ECC Protection

The device offers data corruption protection by offering optional internal ECC. READs and PROGRAMs with internal ECC can be enabled or disabled by setting feature bit ECC_EN. ECC is disabled after device power up, so the default READ and PROGRAM commands operate with internal ECC in the “inactive” state.

To enable/disable ECC, perform the following command sequence:

- Issue the SET FEATURES command (1FH).
- Set the feature bit ECC_EN as you want:
 1. To enable ECC, Set ECC_EN to 1.
 2. To disable ECC, Clear ECC_EN to 0.

During a PROGRAM operation, the device calculates an ECC code on the 2k page in the cache register, before the page is written to the NAND Flash array.

During a READ operation, the page data is read from the array to the cache register, where the ECC code is calculated and compared with the ECC code value read from the array. If error bits are detected, the error is corrected in the cache register. Only corrected data is output on the I/O bus. The ECC status bit indicates whether or not the error correction was successful. The ECC Protection table below shows the ECC protection scheme used throughout a page.

With internal ECC, the user must accommodate the following:

- Spare area definitions provided in the ECC Protection table below.
- ECC can protect according main and spare areas. WRITES to the ECC area are ignored.

Power on Read without internal ECC:

The device will automatically read first page of first block to cache after power on, then host can directly read data from cache for easy boot. However, the data is not promised correctly with ECC disabled.

Table 12 ECC Protection and Spare Area

Min Byte Address	Max Byte Address	ECC Protected	Number Of Bytes	Area	Description
000H	1FFH	Yes	512	Main 0	User data 0
200H	3FFH	Yes	512	Main 1	User data 1
400H	5FFH	Yes	512	Main 2	User data 2
600H	7FFH	Yes	512	Main 3	User data 3
800H	803H	No	4		800H is reserved for bad block mark
804H	805H	Yes	2	Spare 0	User meta data I
806H	812H	Yes	13	Spare 0	ECC for main/spare 0
813H	814H	Yes	2	Spare 1	User meta data I
815H	821H	Yes	13	Spare 1	ECC for main/spare 1
822H	823H	Yes	2	Spare 2	User meta data I
824H	830H	Yes	13	Spare 2	ECC for main/spare 2
831H	832H	Yes	2	Spare 3	User meta data I
833H	83FH	Yes	13	Spare 3	ECC for main/spare 3
840H	87FH	No	64	Spare 4	User meta data II

13. Electrical Characteristics

13.1. Absolute Maximum Ratings

Table 13 Absolute Maximum Ratings

Operating Temperature	-40°C to +85°C
Storage Temperature	-65°C to +150°C
Voltage on I/O Pin with Respect to Ground	-0.5V to 2.7V
V _{CC}	-0.5V to 2.7V

Note: Stresses beyond those listed under “Absolute Maximum Ratings” may cause permanent damage to the device. This is a stress rating only and functional operation of the device at these or any other conditions beyond those indicated in the operational sections of this specification are not implied. Exposure to absolute maximum rating conditions for extended periods may affect device reliability.

13.2. Pin Capacitance

Table 14 Pin Capacitance

Applicable over recommended operating range from: T_A = +25°C, f = 1 MHz.

Symbol	Test Condition	Max	Units	Conditions
C _{IN} ⁽¹⁾	Input Capacitance	6	pF	V _{IN} = 0V
C _{OUT} ⁽¹⁾	Output Capacitance	8	pF	V _{OUT} = 0V

Note: 1. characterized and is not 100% tested.

13.3. Power-up and Power-Down Timing

Figure 32 Power-On Timing

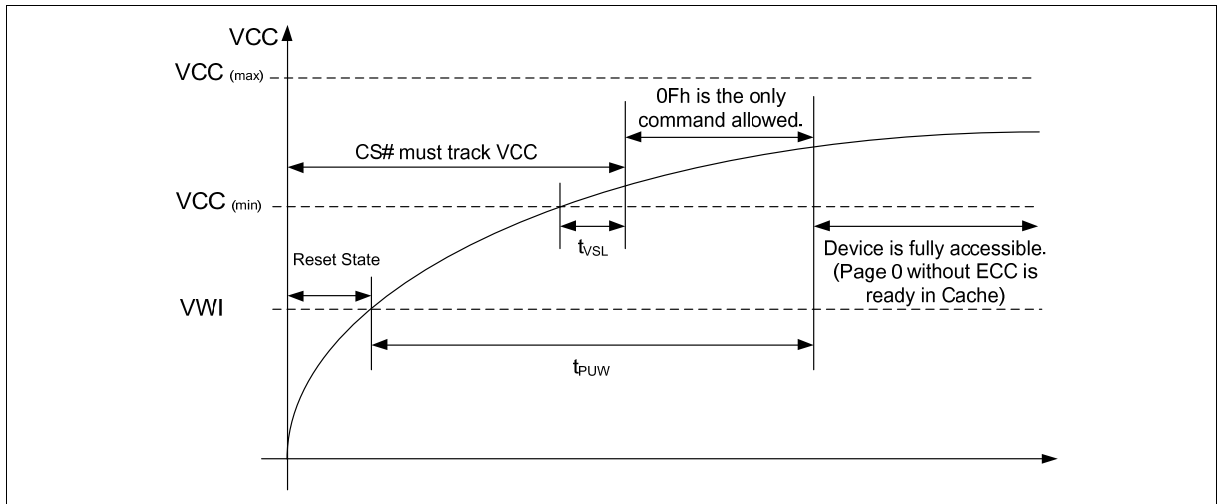

Table 15 Power-On Timing and Write Inhibit Threshold

PARAMETER	SYMBOL	SPEC		UNIT
		MIN	MAX	
VCC (min) to CS# Low	t _{VSL}	1		ms
Time Delay Before Write Instruction	t _{PUW}	8		ms
Write Inhibit Voltage	VWI		1.6	V

13.4. DC Electrical Characteristics

Table 16 DC Characteristics

Applicable over recommended operating range from: $T_A = -40^{\circ}\text{C}$ to $+85^{\circ}\text{C}$, $V_{CC} = 1.7\text{V}$ to 1.95V , (unless otherwise noted).

SYMBOL	PARAMETER	CONDITIONS	SPEC			UNIT
			MIN	TYP	MAX	
VCC	Supply Voltage		1.7		1.95	V
I _{LI}	Input Leakage Current				±2	μA
I _{LO}	Output Leakage Current				±2	μA
I _{CC1}	Standby Current	$V_{CC}=1.95\text{V}$, CS# = VCC, $V_{IN} = \text{VSS or VCC}$			70	μA
I _{CC2}	Operating Current	CLK=0.1VCC/0.9VCC F _{CLK} =88MHz			40	mA
V _{IL} ⁽¹⁾	Input Low Voltage		-0.5		0.2V _{CC}	V
V _{IH} ⁽¹⁾	Input High Voltage		0.7V _{CC}		V _{CC} +0.4	V
V _{OL}	Output Low Voltage	I _{OL} = 1.6 mA			0.4	V
V _{OH}	Output High Voltage	I _{OH} = -100 μA	V _{CC} -0.2			V

Notes:

1. V_{IL} min and V_{IH} max are reference only and are not tested.

13.5. AC Measurement Conditions

Table 17 AC Measurement Conditions

SYMBOL	PARAMETER	SPEC		UNIT
		MIN	MAX	
C _L	Load Capacitance		30	pF
T _R , T _F	Input Rise and Fall Times		5	ns
V _{IN}	Input Pulse Voltages	0.2 V _{CC} to 0.8 V _{CC}		V
IN	Input Timing Reference Voltages	0.3 V _{CC} to 0.7 V _{CC}		V
OUT	Output Timing Reference Voltages	0.5V _{CC}		V

Figure 33 AC Measurement I/O Waveform

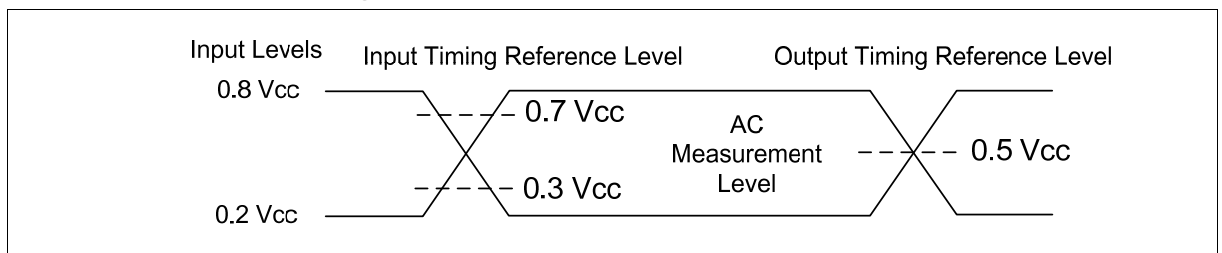

13.6. AC Electrical Characteristics

Table 18 AC Characteristics

Applicable over recommended operating range from: $T_A = -40^{\circ}\text{C}$ to $+85^{\circ}\text{C}$, $V_{CC} = 1.7\text{V}$ to 1.95V , (unless otherwise noted).

SYMBOL	PARAMETER	SPEC			UNIT
		MIN	TYP	MAX	
F _C	Serial Clock Frequency for: all command			88	MHz
t _{CH1} ⁽¹⁾	Serial Clock High Time	4.5			ns

SYMBOL	PARAMETER	SPEC			UNIT
		MIN	TYP	MAX	
$t_{CL1}^{(1)}$	Serial Clock Low Time	4.5			ns
$t_{CLCH}^{(2)}$	Serial Clock Rise Time (Slew Rate)	0.1			V/ns
$t_{CHCL}^{(2)}$	Serial Clock Fall Time (Slew Rate)	0.1			V/ns
t_{SLCH}	CS# Active Setup Time	5			ns
t_{CHSH}	CS# Active Hold Time	5			ns
t_{SHCH}	CS# Not Active Setup Time	5			ns
t_{CHSL}	CS# Not Active Hold Time	5			ns
t_{SHSL}/t_{CS}	CS# High Time	20			ns
$t_{SHQZ}^{(2)}$	Output Disable Time			10	ns
t_{CLQX}	Output Hold Time	0			ns
t_{DVCH}	Data In Setup Time	2			ns
t_{CHDX}	Data In Hold Time	3			ns
t_{HLCH}	HOLD# Low Setup Time (relative to CLK)	5			ns
t_{HHCH}	HOLD# High Setup Time (relative to CLK)	5			ns
t_{CHHH}	HOLD# Low Hold Time (relative to CLK)	5			ns
t_{CHHL}	HOLD# High Hold Time (relative to CLK)	5			ns
$t_{HLQZ}^{(2)}$	HOLD# Low to High-Z Output			15	ns
$t_{HHQX}^{(2)}$	HOLD# High to Low-Z Output			15	ns
t_{CLQV}	Output Valid from CLK			9	ns
t_{WHSL}	WP# Setup Time before CS# Low	20			ns
t_{SHWL}	WP# Hold Time after CS# High	100			ns
t_{LCK}	BLOCK LOCK/UNLOCK time	Individual		5	μ s
		Global		64	
t_{IO_skew}	First IO to last IO data valid time			600	ps

Notes:

- $T_{CH1} + T_{CL1} \geq 1 / F_C$;
- characterized and not 100% tested.

Table 19 Performance Timing

SYMBOL	PARAMETER	SPEC			UNIT
		MIN	TYP	MAX	
t_{RST}	CS# High to Next Command After Reset(FFh)			500	μ s
t_{RD}	Page Read From Array (with ECC)		240	280	μ s
	Page Read From Array (without ECC)		120	140	
t_{PROG}	Page Program (with ECC)			800	μ s
	Page Program (without ECC)		400	700	
t_{ERS}	Block Erase		3	10	ms

Figure 34 Serial Output Timing

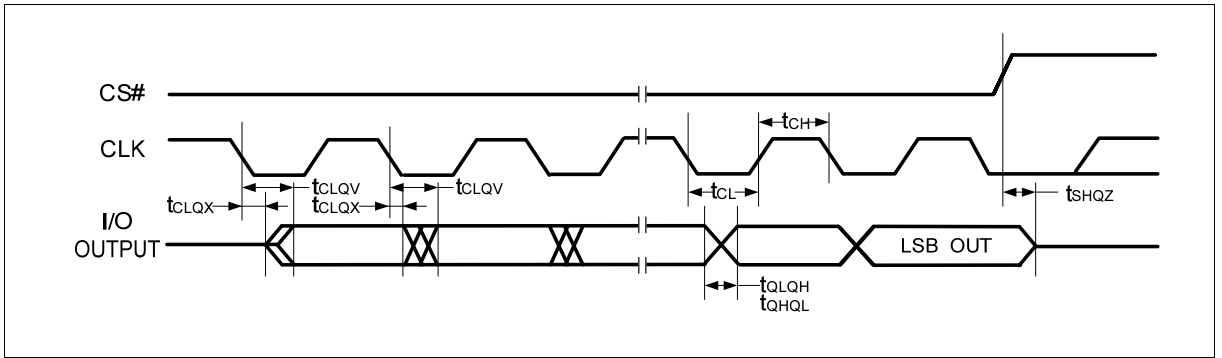

Figure 35 Serial Input Timing

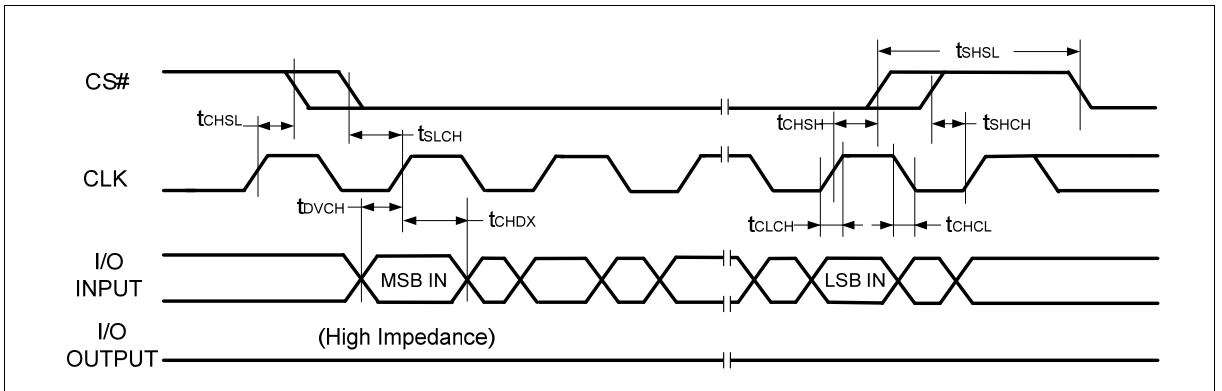
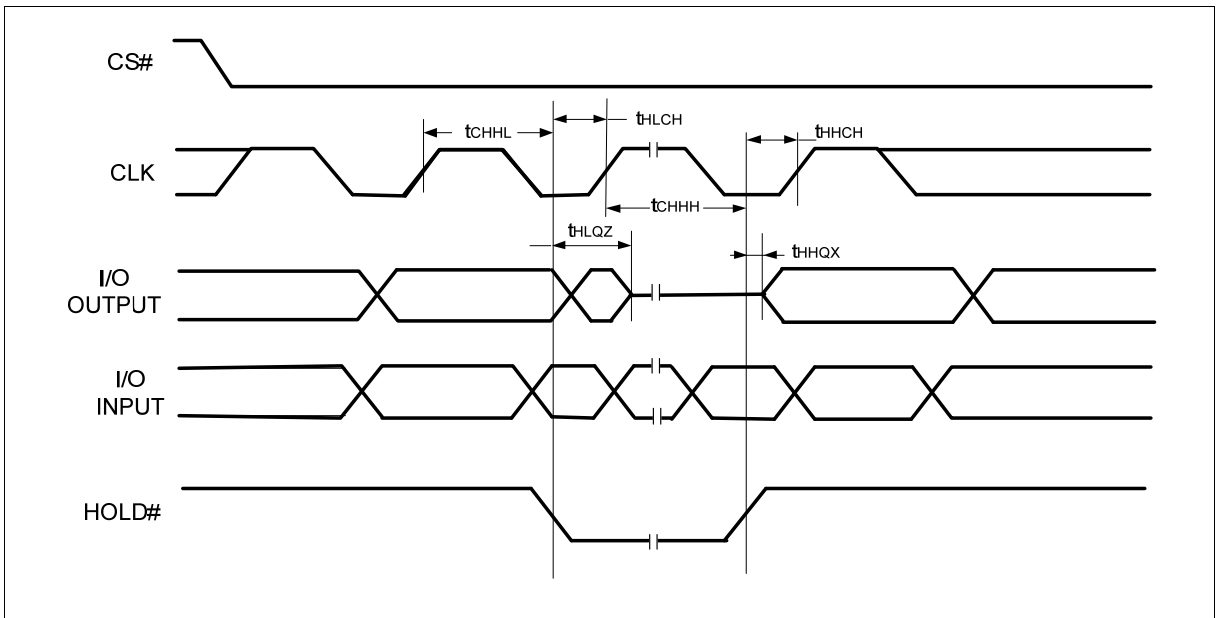
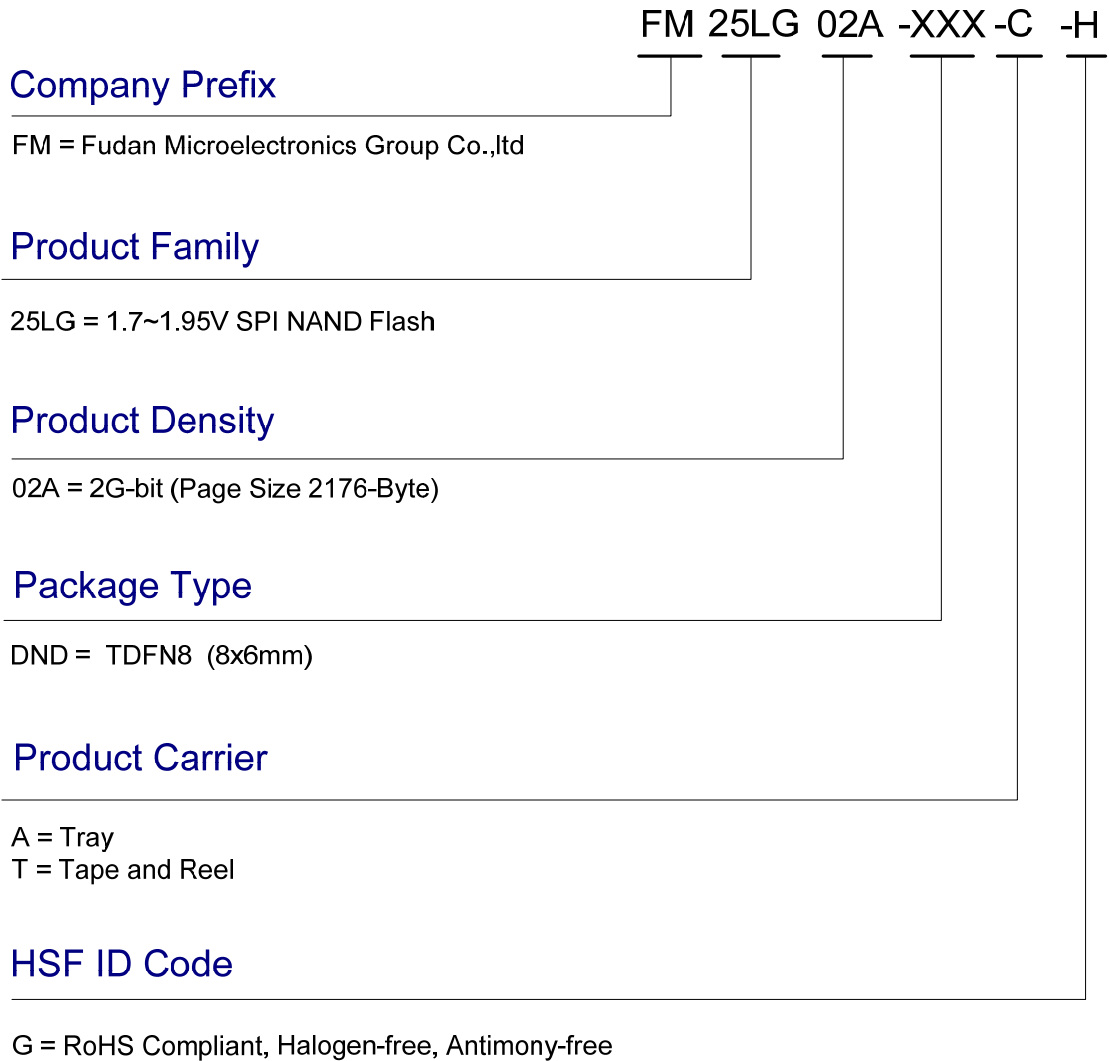

Figure 36 Hold Timing





14. Ordering Information



15. Part Marking Scheme

TDFN8 (8x6mm)

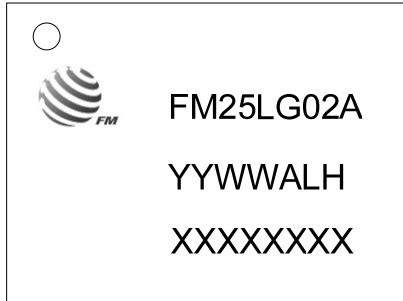

FM25LG02A

Product Density

YYWWALH

HSF ID Code

G = RoHS Compliant, Halogen-free, Antimony-free

Package Lot Number (just with 0~9, A~Z)

Assembly's Code

Work week during which the product was molded (eg..week 12)

The last two digits of the year in which the product was sealed/molded

XXXXXXXXX

Wafer Lot Number (the length is not fixed)

16. Packaging Information

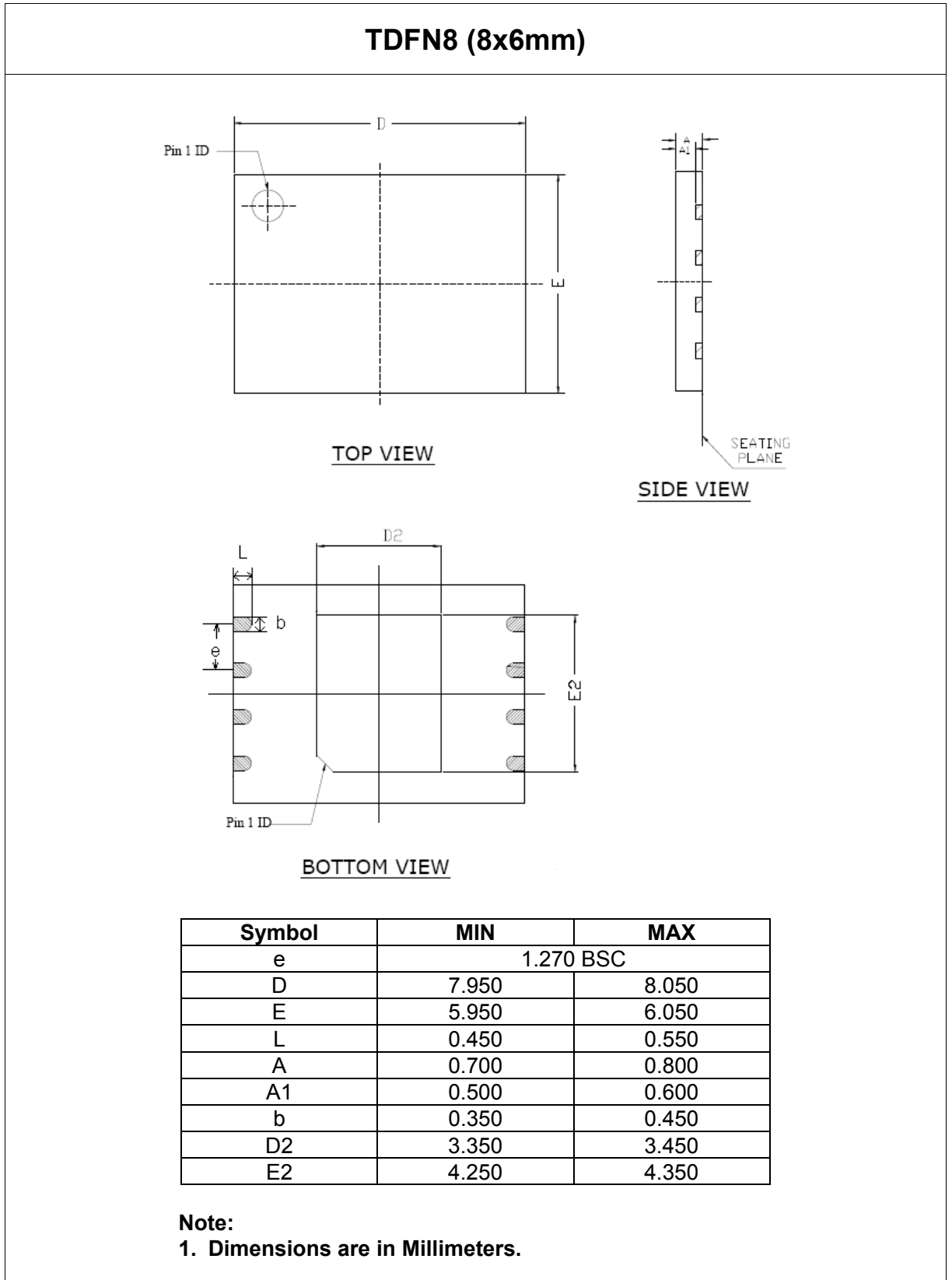



17. Revision History

Version	Publication date	Pages	Paragraph or Illustration	Revise Description
preliminary	Oct. 2015	41		1. Initial Document Release
1.0	Jan. 2016	42		1. Modified Power-up Timing Sequence 2. Modified AC/DC Electrical Characteristics



Sales and Service

Shanghai Fudan Microelectronics Group Co., Ltd.

Address: Bldg No. 4, 127 Guotai Rd,
Shanghai City China.

Postcode: 200433

Tel: (86-021) 6565 5050

Fax: (86-021) 6565 9115

Shanghai Fudan Microelectronics (HK) Co., Ltd.

Address: Unit 506, 5/F., East Ocean Centre, 98 Granville
Road, Tsimshatsui East, Kowloon, Hong Kong

Tel: (852) 2116 3288 2116 3338

Fax: (852) 2116 0882

Beijing Office

Address: Room 423, Bldg B, Gehua Building,
1 QingLong Hutong, Dongzhimen Alley north Street,
Dongcheng District, Beijing City, China.

Postcode: 100007

Tel: (86-010) 8418 6608

Fax: (86-010) 8418 6211

Shenzhen Office

Address: Room.1301, Century Bldg, No. 4002, Shengtingyuan Hotel,
Huaqiang Rd (North),
Shenzhen City, China.

Postcode: 518028

Tel: (86-0755) 8335 0911 8335 1011 8335 2011 8335 0611

Fax: (86-0755) 8335 9011

Shanghai Fudan Microelectronics (HK) Ltd Taiwan Representative Office

Address: Unit 1225, 12F., No 252, Sec.1 Neihu Rd., Neihu
Dist., Taipei City 114, Taiwan

Tel : (886-2) 7721 1890 (886-2) 7721 1889

Fax: (886-2) 7722 3888

Shanghai Fudan Microelectronics (HK) Ltd Singapore Representative Office

Address: 237, Alexandra Road, #07-01 The Alexcier,
Singapore 159929

Tel: (65) 6472 3688

Fax: (65) 6472 3669

Shanghai Fudan Microelectronics Group Co., Ltd NA Office

Address: 2490 W. Ray Road Suite#2
Chandler, AZ 85224 USA

Tel: (480) 857-6500 ext 18

Web Site: <http://www.fmsh.com/>