



ANSI/AAMI ES60601-1



EN60601-1



IEC60601-1



■ Features

- 5"× 3" compact size
- Medical safety approved (2 x MOPP) according to ANSI/AAMI ES60601-1 and IEC/EN60601-1
- Suitable for BF application with appropriate system consideration
- 110W convention, 160W force air
- EMI class B for class I configuration
- No load power consumption under 0.5W by PS-ON control (G model)
- 5Vdc standby output, Power Good, Power Fail ; Remote sense for 5~15V
- Protections: Short circuit / Overload / Over voltage / Over temperature
- 3 years warranty

■ Applications

- Oral irrigator
- Hemodialysis machine
- Medical monitors
- Sleep apnea devices
- Pumps machine

■ Description

RPS-160 is a 160W highly reliable green PCB type medical power supply with a high power density on a 5" by 3" footprint. It accepts 90~264VAC input and offers various models with the output voltages between 5V and 48V. The working efficiency is up to 88% and the extremely low no load power consumption is down below 0.5W. RPS-160 is able to be used for Class I (with FG) system design. The extremely low leakage current is less than 160 μ A. In addition, it conforms to the international medical regulations (2*MOPP) and EMC EN55011, perfectly fitting all kinds of BF rated "patient contact" medical system equipment.

■ Model Encoding

RPS **G** - **160** - **5**

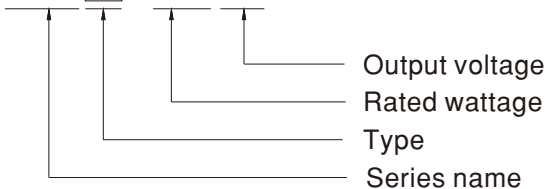

Type	Description	Note
Blank	Without 5Vsb	In stock
G	With 5Vsb & No load power consumption <0.5W	In stock

SPECIFICATION

MODEL	RPS□-160-5	RPS□-160-12	RPS□-160-15	RPS□-160-24	RPS□-160-48		
OUTPUT	DC VOLTAGE	5V	12V	15V	24V	48V	
	RATED CURRENT (20.5CFM)	30A	12.9A	10.3A	6.5A	3.25A	
	CURRENT	Convection	0 ~ 20A	0 ~ 9.1A	0 ~ 7.3A	0 ~ 4.6A	0 ~ 2.3A
		20.5CFM	0 ~ 30A	0 ~ 12.9A	0 ~ 10.3A	0 ~ 6.5A	0 ~ 3.25A
	RATED POWER	Convection Note.2	103W	112.2W	112.5W	113.4W	113.4W
		20.5CFM Note.3	155W	159.8W	159.5W	161W	161W
	RIPPLE & NOISE (max.) Note.4	80mVp-p	80mVp-p	120mVp-p	120mVp-p	150mVp-p	
	VOLTAGE ADJ. RANGE(main output)	4.5 ~ 5.5V	10.8 ~ 13.2V	13.5 ~ 16.5V	22 ~ 27V	43.2 ~ 52.8V	
	VOLTAGE TOLERANCE Note.5	±4.0%	±3.0%	±3.0%	±2.0%	±2.0%	
	LINE REGULATION	±0.5%	±0.5%	±0.5%	±0.5%	±0.5%	
LOAD REGULATION	±1.0%	±1.0%	±1.0%	±1.0%	±1.0%		
SETUP, RISE TIME	1800ms, 30ms/230VAC 3500ms, 30ms/115VAC at full load						
HOLD UP TIME (Typ.)	20ms/115VAC 25ms/230VAC at full load						
INPUT	VOLTAGE RANGE Note.6	90 ~ 264VAC 127 ~ 370VDC					
	FREQUENCY RANGE	47 ~ 63Hz					
	POWER FACTOR (Typ.)	PF>0.93/230VAC PF>0.98/115VAC at full load					
	EFFICIENCY (Typ.)	86%	87%	87%	87%	88%	
	AC CURRENT (Typ.)	2A/115VAC 1.1A/230VAC					
	INRUSH CURRENT (Typ.)	COLD START 35A/115VAC 70A/230VAC					
	LEAKAGE CURRENT Note.7	Earth leakage current < 160µA/264VAC , Touch current < 100µA/264VAC					
PROTECTION	OVERLOAD	105 ~ 135% rated output power Protection type : Hiccup mode, recovers automatically after fault condition is removed					
	OVER VOLTAGE	5.7 ~ 6.8V	13.8 ~ 16.2V	17.2 ~ 20.3V	27.6 ~ 32.4V	55.2 ~ 64.8V	
	OVER TEMPERATURE	TSW1: Shut down o/p voltage, recovers automatically after temperature goes down TSW2: Shut down o/p voltage, re-power on to recover					
FUNCTION	5V STANDBY (G model)	5Vsb : 5V@0.6A without fan, 0.8A with fan 20.5CFM ; Tolerance ± 2%, ripple : 50mVp-p(max.)					
	PS-ON INPUT SIGNAL (G model)	Power on: PS-ON = "Hi" or " > 2 ~ 5V" ; Power off: PS-ON = "Low" or " < 0 ~ 0.5V"					
	POWER GOOD / POWER FAIL	500ms>PG>10ms PF>1ms					
	REMOTE SENSE	5 ~ 15V					
ENVIRONMENT	WORKING TEMP.	-20 ~ +70°C (Refer to "Derating Curve")					
	WORKING HUMIDITY	20 ~ 90% RH non-condensing					
	STORAGE TEMP., HUMIDITY	-40 ~ +85°C, 10 ~ 95% RH non-condensing					
	TEMP. COEFFICIENT	±0.03%/°C (0 ~ 50°C)					
	VIBRATION	10 ~ 500Hz, 2G 10min./1cycle, 60min. each along X, Y, Z axes					
	OPERATING ALTITUDE Note.8	4000 meters					
SAFETY & EMC (Note 10)	SAFETY STANDARDS	IEC60601-1, EAC TP TC 004,ANSI/AAMI ES60601-1, CAN/CSA-C22.2 No. 60601-1:14 - Edition 3 approved, TUV EN60601-1 approved ; Design refer to EN60335-1					
	ISOLATION LEVEL	Primary-Secondary: 2xMOPP, Primary-Earth:1xMOPP, Secondary-Earth:1xMOPP					
	WITHSTAND VOLTAGE	I/P-O/P:4KVAC I/P-FG:2KVAC O/P-FG:1.5KVAC					
	ISOLATION RESISTANCE	I/P-O/P, I/P-FG, O/P-FG:100M Ohms / 500VDC / 25°C / 70% RH					
	EMC EMISSION	Parameter	Standard		Test Level / Note		
		Conducted emission	EN55011 (CISPR11)		Class B		
		Radiated emission	EN55011 (CISPR11)		Class B		
		Harmonic current	EN61000-3-2		Class A		
		Voltage flicker	EN61000-3-3		----		
	EMC IMMUNITY	EN60601-1-2					
		Parameter	Standard		Test Level / Note		
		ESD	EN61000-4-2		Level 4, 15KV air ; Level 4, 8KV contact		
		RF field susceptibility	EN61000-4-3		Level 3, 10V/m(80MHz~2.7GHz) Table 9, 9~28V/m(385MHz~5.78GHz)		
		EFT bursts	EN61000-4-4		Level 3, 2KV		
Surge susceptibility		EN61000-4-5		Level 4, 4KV/Line-FG ; 2KV/Line-Line			
Conducted susceptibility		EN61000-4-6		Level 3, 10V			
Magnetic field immunity		EN61000-4-8		Level 4, 30A/m			
Voltage dip, interruption	EN61000-4-11		100% dip 1 periods, 30% dip 25 periods, 100% interruptions 250 periods				
OTHERS	MTBF	230.5K hrs min. MIL-HDBK-217F (25°C)					
	DIMENSION (L*W*H)	127*76.2*34.6mm or 5" * 3" *1.36" inch					
	PACKING	0.32Kg; 36pcs/12.5Kg/0.79CUFT					
NOTE	<p>1. All parameters NOT specially mentioned are measured at 230VAC input, rated load and 25°C of ambient temperature.</p> <p>2. The rated power includes 5Vsb @ 0.6A.</p> <p>3. The rated power includes 5Vsb @ 0.8A.</p> <p>4. Ripple & noise are measured at 20MHz of bandwidth by using a 12" twisted pair-wire terminated with a 0.1µf & 47µf parallel capacitor.</p> <p>5. Tolerance : includes set up tolerance, line regulation and load regulation.</p> <p>6. Derating may be needed under low input voltages. Please check the derating curve for more details.</p> <p>7. Touch current was measured from primary input to DC output.</p> <p>8. The ambient temperature derating of 3.5°C/1000m with fanless models and of 5°C/1000m with fan models for operating altitude higher than 2000m(6500ft).</p> <p>9. HS1,HS2 & HS3 can not be shorted.</p> <p>10. The power supply is considered a component which will be installed into a final equipment. All the EMC tests are been executed by mounting the unit on a 360mm*360mm metal plate with 1mm of thickness. The final equipment must be re-confirmed that it still meets EMC directives. For guidance on how to perform these EMC tests, please refer to "EMI testing of component power supplies." (as available on http://www.meanwell.com)</p>						

■ Block Diagram

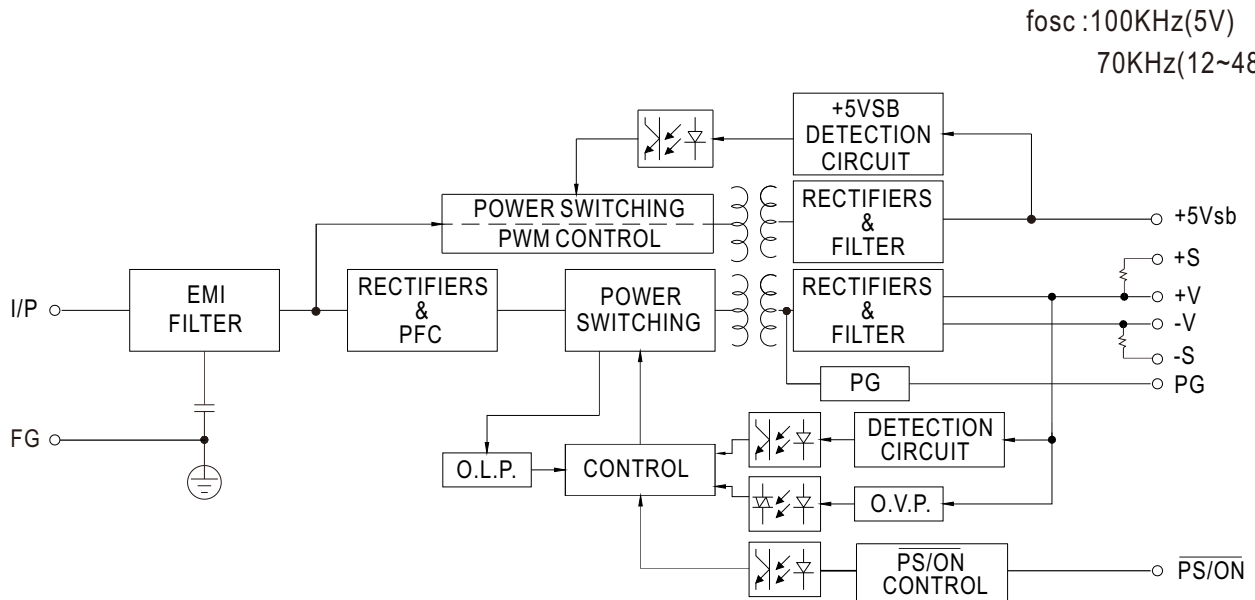

■ Derating Curve

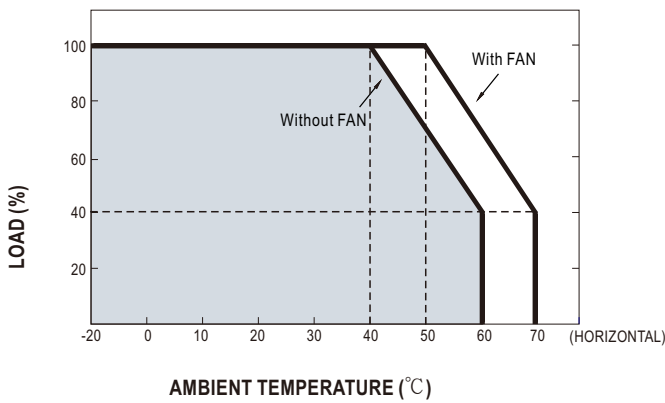

■ Output Derating VS Input Voltage

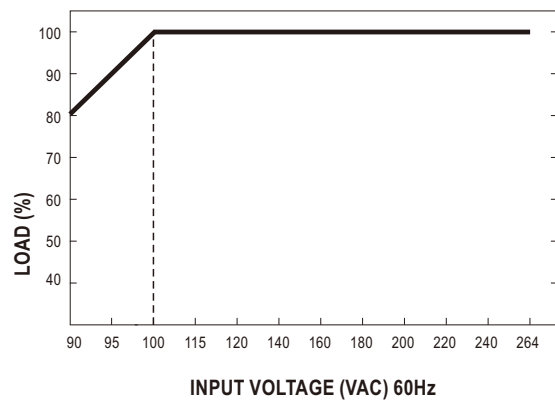

■ Mechanical Specification

Unit:mm

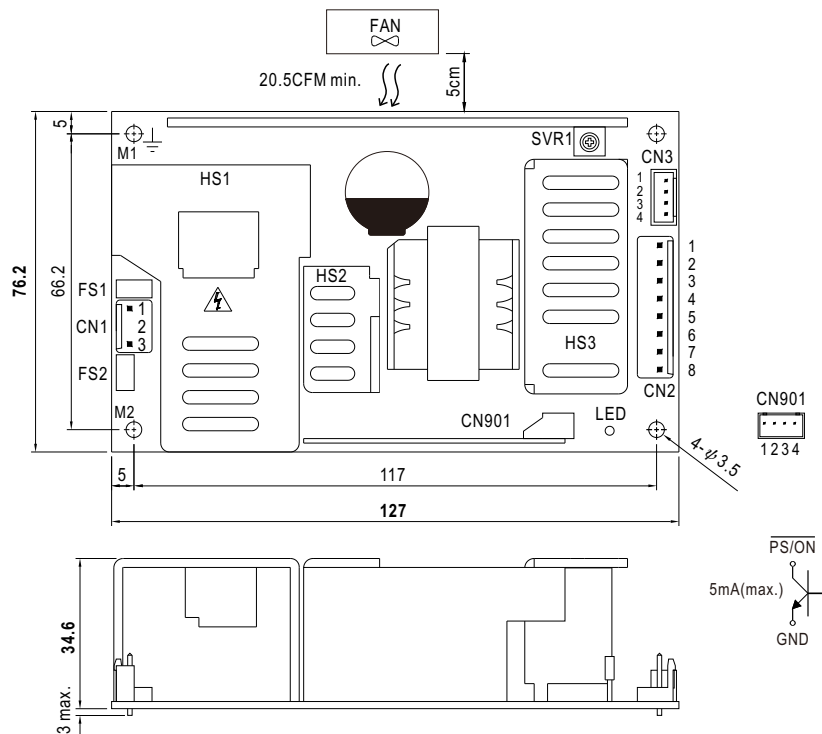

AC Input Connector (CN1) : JST B3P-VH or equivalent

Pin No.	Assignment	Mating Housing	Terminal
1	AC/L	JST VHR or equivalent	JST SVH-21T-P1.1 or equivalent
2	No Pin		
3	AC/N		

Power Good Connector(CN3):JST B4B-XH or equivalent

Pin No.	Status	Mating Housing	Terminal
1	PG	JST XHP or equivalent	JST SXH-001T-P0.6 or equivalent
2	GND		
3	-S		
4	+S		

DC Output Connector (CN2) : JST B8P-VH or equivalent

Pin No.	Assignment	Mating Housing	Terminal
1,2,3,4	+V	JST VHR or equivalent	JST SVH-21T-P1.1 or equivalent
5,6,7,8	-V		

5VSB Connector(CN901) : JST B-XH or equivalent

Pin No.	Assignment	Mating Housing	Terminal
1	PS/ON	JST XHP or equivalent	JST SXH-001T or equivalent
2,4	GND		
3	5VSB		

⊕ : Grounding Required

- ⚠ 1.HS1,HS2,HS3 cannot be shorted.
- 2.M1 is safety ground. For better EMC performance,Please secure an electrical connection between M1,M2, and chassis grounding.

■ Installation Manual

Please refer to : <http://www.meanwell.com/manual.html>