

# TA Series

## Analog And Non-Indicating Type, PID Control, Set Temperature By Dial

### ■ Features

- Improved control performance with built-in microcomputer
- Adopting new Auto-tuning PID control algorithm : Selectable ON/OFF, PID control (the external switch)
- Easy to check controlling status with deviation indicators : Deviation LED (red, green), output LED (red) indicators
- Dial setting output OFF function
- Sensor broken display function



⚠ Please read "Caution for your safety" in operation manual before using.



### ■ Ordering Information





**TA S - B 4 R P 4 C**

Unit	C	Celsius °C			
	F	Fahrenheit °F			
Temperature range for each sensor		°C	°F	Temperature sensor	
	0	-50 to 100	-58 to 212	DPt	— —
	1	0 to 100	32 to 212	DPt	— K (CA)
	2	0 to 200	32 to 392	DPt	J (IC) K (CA)
	3	0 to 300	32 to 572	—	J (IC) —
	4	0 to 400	32 to 752	DPt	J (IC) K (CA)
	6	0 to 600	32 to 1,112	—	— K (CA)
	8	0 to 800	32 to 1,472	—	— K (CA)
	C	0 to 1,200	32 to 2,192	—	— K (CA)
Sensor input type	P	DPt100Ω			
	J	J (IC)			
	K	K (CA)			
Control output	R	Relay output			
	S	SSR drive output			
Power supply	4	100-240VAC 50/60Hz			
Control method	B	ON/OFF control & PID control combined			
	S	DIN W48 x H48mm (8-pin plug type) <sup>※1</sup>			
	M	DIN W72 x H72mm			
	L	DIN W96 x H96mm			
Size					
Item	TA	Analog setting type temperature controller			

※1: 8-pin socket (PG-08, PS-08(N)) is sold separately.

# Analog Setting Non-Indicating Type, PID Control

## Specifications

Series	TAS	TAM	TAL
Power supply	100-240VAC 50/60Hz		
Allowable voltage range	90 to 110% of rated voltage		
Power consumption	Max. 4VA		
Size	DIN W48×H48mm	DIN W72×H72mm	DIN W96×H96mm
Display method	Deviation LED (red, green), Output LED (red)		
Setting type	Dial setting		
Setting accuracy <sup>※1</sup>	F.S. ±2% (room temperature 23°C±5°C)		
Input type	RTD	DPT100Ω (allowable line resistance max. 5Ω per a wire)	
	Thermocouples	K (CA), J (IC)	
Control	ON/OFF Control	Hysteresis: 2°C fixed	
	PID Control	Control period: Relay output - 20 sec / SSR drive output - 2 sec	
Control output	Relay	250VAC 3A 1c	
	SSR	12VDC±2V 20mA Max.	
Functions	PV deviation indicatable, Error indicatable		
Sampling period	100ms		
Dielectric strength	2,000VAC 50/60Hz for 1 min (between input terminal and power terminal)		
Vibration	0.75mm amplitude at frequency of 5 to 55Hz (for 1 min) in each X, Y, Z direction for 2 hours		
Relay life cycle	Mechanical	Min. 10,000,000 operations (18,000 operations/hr)	
	Electrical	Min. 100,000 operations (900 operations/hr)	
Insulation resistance	Min. 100MΩ (at 500VDC megger)		
Noise immunity	±2kV R-phase, S-phase the square wave noise (pulse width: 1us) by the noise simulator		
Memory retention	Approx. 10 years (when using non-volatile semiconductor memory type)		
Environment	Ambient temperature	-10 to 50°C, storage: -20 to 60°C	
	Ambient humidity	35 to 85%RH, storage: 35 to 85%RH	
Insulation type	Double insulation or reinforced insulation (mark:  , dielectric strength between the measuring input part and the power part: 2kV)		
Approval	   		
Weight <sup>※2</sup>	Approx. 107g (approx. 69g)	Approx. 171g (approx. 109g)	Approx. 232g (approx. 147g)

※1: <at room temperature range> Below 100 °C model is F.S. ±3%

<out of room temperature range> Below 100°C model is F.S. ±4%, Over 100°C model is F.S. ±3%

※2: The weight includes packaging. The weight in parenthesis is for unit only.

※Environment resistance is rated at no freezing or condensation.

## Connections

※RTD: DPT100Ω (3-wire type)

※Thermocouple: K (CA), J (IC)

### TAS

(※Socket (PG-08, PS-08 (N)) is sold separately)

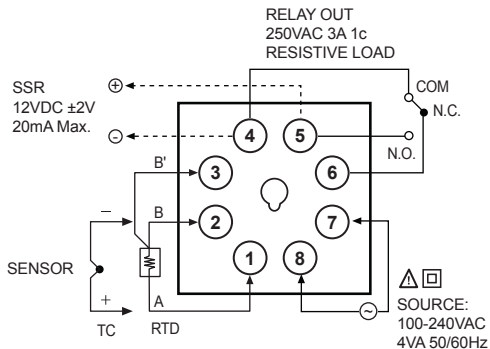

### TAM

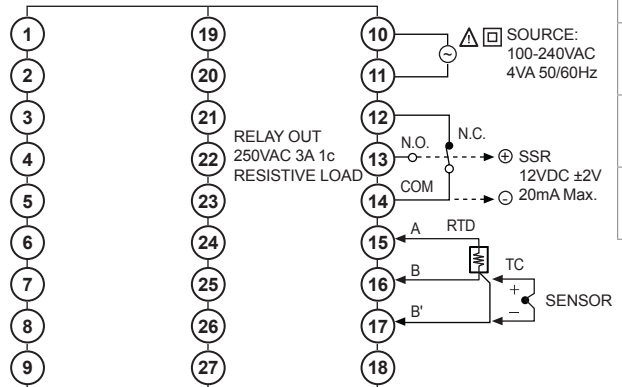

(A) Photoelectric Sensors
(B) Fiber Optic Sensors
(C) Door/Area Sensors
(D) Proximity Sensors
(E) Pressure Sensors
(F) Rotary Encoders
(G) Connectors/ Connector Cables/ Sensor Distribution Boxes/Sockets
(H) Temperature Controllers
(I) SSRs / Power Controllers
(J) Counters
(K) Timers
(L) Panel Meters
(M) Tacho / Speed / Pulse Meters
(N) Display Units
(O) Sensor Controllers
(P) Switching Mode Power Supplies
(Q) Stepper Motors & Drivers & Controllers
(R) Graphic/ Logic Panels
(S) Field Network Devices
(T) Software

# TA Series

## Connections

※RTD: DPT100Ω (3-wire type) ※Thermocouple: K (CA), J (IC)

### TAL

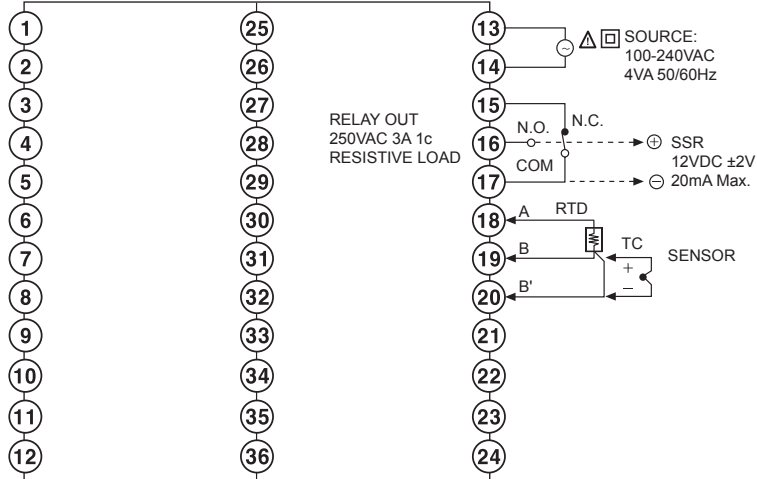

## Dimensions

(unit: mm)

### TAS

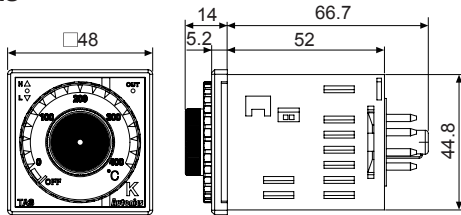

### TAM

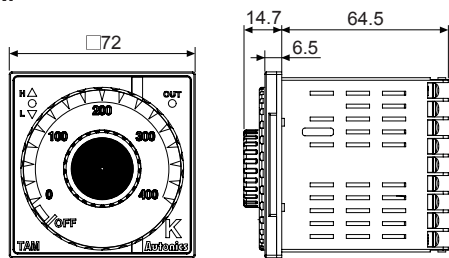

### TAL

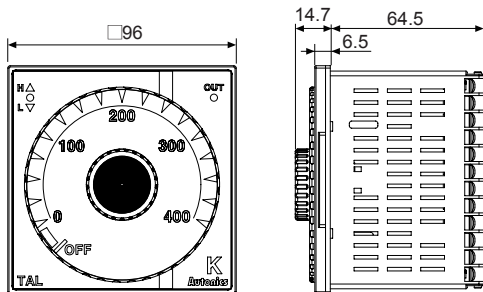

### Panel cut-out

(unit: mm)

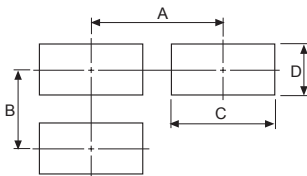

Series	Size			
	A	B	C	D
TAS	Min. 65	Min. 65	45 <sup>+0.6</sup> <sub>0</sub>	45 <sup>+0.6</sup> <sub>0</sub>
TAM	Min. 90	Min. 90	68 <sup>+0.7</sup> <sub>0</sub>	68 <sup>+0.7</sup> <sub>0</sub>
TAL	Min. 115	Min. 115	92 <sup>+0.8</sup> <sub>0</sub>	92 <sup>+0.8</sup> <sub>0</sub>

# Analog Setting Non-Indicating Type, PID Control

## ● Bracket

### ● TAS

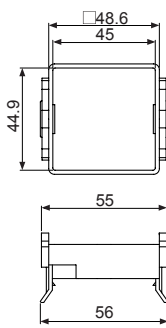

### ● TAM, TAL

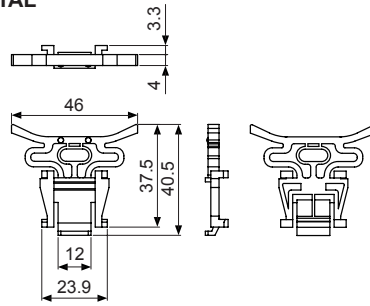

(unit: mm)

## ● Terminal cover (sold separately)

### ● RMA-COVER (72×72mm)

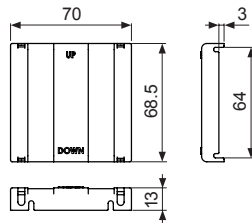

### ● RLA-COVER (96×96mm)

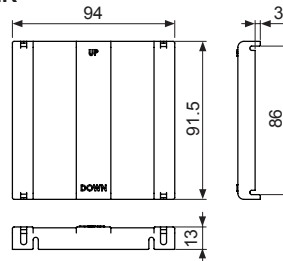

## ■ Mounting

### ● TAS (48×48mm) Series

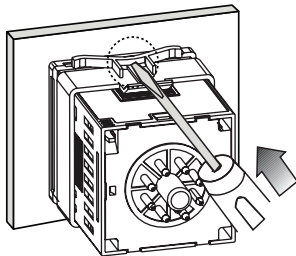

### ● Other Series

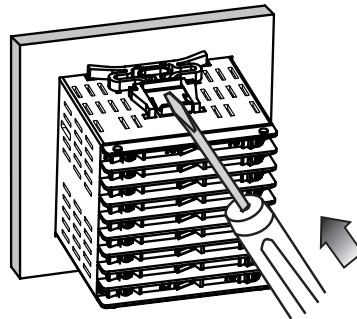

※Mount the product on the panel, fasten bracket by pushing with tools as shown above.

(A)	Photoelectric Sensors
(B)	Fiber Optic Sensors
(C)	Door/Area Sensors
(D)	Proximity Sensors
(E)	Pressure Sensors
(F)	Rotary Encoders
(G)	Connectors/ Connector Cables/ Sensor Distribution Boxes/Sockets
(H)	Temperature Controllers
(I)	SSRs / Power Controllers
(J)	Counters
(K)	Timers
(L)	Panel Meters
(M)	Tacho / Speed / Pulse Meters
(N)	Display Units
(O)	Sensor Controllers
(P)	Switching Mode Power Supplies
(Q)	Stepper Motors & Drivers & Controllers
(R)	Graphic/ Logic Panels
(S)	Field Network Devices
(T)	Software

# TA Series

## Unit Description

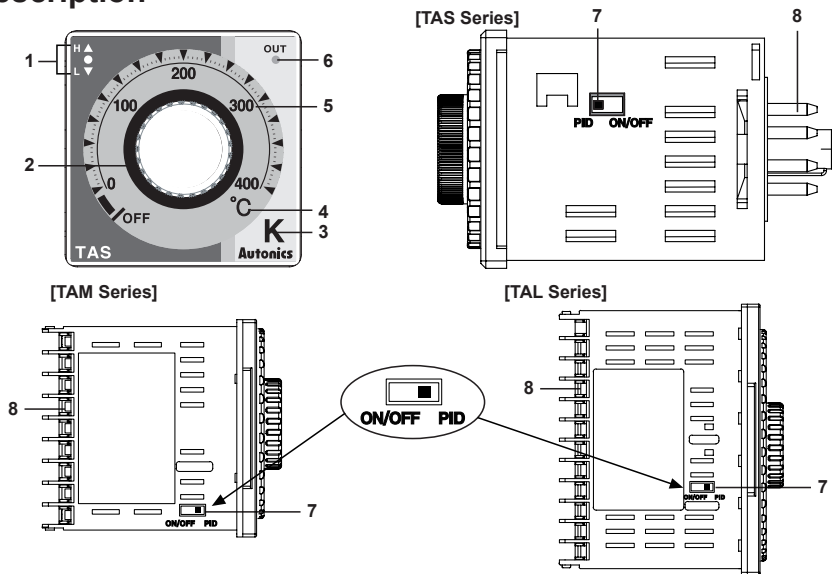

**1. Deviation indicator:** It shows deviation of present temperature (PV) based on set temperature (SV) by LED.

PV deviation temperature	Input deviation indicator [Deviation indicator: ● (green), ▲/▼ (red)]
Input sensor OPEN	▲ + ● + ▼ indicators flash (every 0.5 sec)
Exceed max. input value	▲ indicator flashes (every 0.5 sec)
More than 10°C	▲ indicator turns ON
More than 2°C to less than or equal to 10°C	▲ + ● indicators turn ON
Less than or equal to ±2°C	● indicator turns ON
More than -2°C to less than or equal to -10°C	● + ▼ indicators turn ON
More than -10°C	▼ indicator turns ON
Less than min. input value	▼ indicator flashes (every 0.5 sec)

※This is the same as Fahrenheit (°F).

※When power is on, all indicators light for 2 sec, then they turn off and control operation starts.

### 2. Set temperature (SV) dial:

Dial to change set temperature (SV). When changing set temperature, it is applied after 2 sec for the stable input.

### 3. Input sensor type:

Indicates sensor type of present value. Input sensor type or input range each product is shown in the below table.

Input sensor	Range No.	Temperature range (°C)	Temperature range (°F)	
Thermocouple	K (CA)	1	0 to 100	32 to 212
		2	0 to 200	32 to 392
		4	0 to 400	32 to 752
		6	0 to 600	32 to 1,112
	J (IC)	8	0 to 800	32 to 1,472
		C	0 to 1,200	32 to 2,192
		2	0 to 200	32 to 392
		3	0 to 300	32 to 572
RTD	DPT100Ω	4	0 to 400	32 to 752
		0	-50 to 100	-58 to 212
		1	0 to 100	32 to 212
		2	0 to 200	32 to 392

※Set temperature within input range each sensor.

**4. Temperature unit:** Indicates temperature unit (°C, °F) of set temperature (SV) and present value (PV).

**5. Temperature range:** Indicates temperature range of set temperature (SV).

**6. Control output indicator:** Turns ON when control output (Relay output/SSR drive output).

**7. Control mode selector switch:** Select PID control (front part) or ON/OFF control (rear part) using switch.

**8. Terminal:** Terminals for external connections. For detail, refer to ■ Connections.

## ■ Functions

### ● SSR drive output

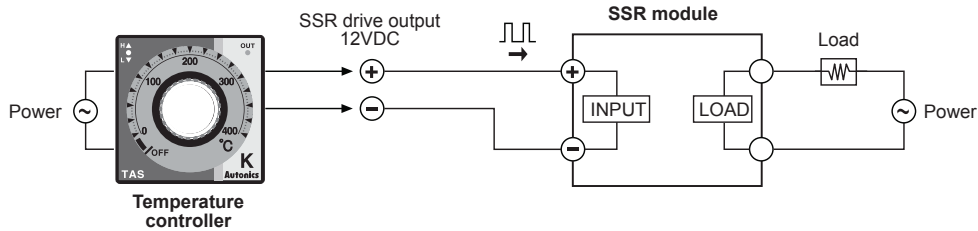

### ● ON/OFF control

ON/OFF control function is for controlling temperature by comparing present temperature (PV) to setting temperature (SV). ON/OFF control is fixed on reverse operation (Heating).

Output turns on to supply power to heater when present temperature (PV) falls lower than setting temperature (SV) and the output turns off to turn off heater when present temperature (PV) is higher than setting temperature (SV).

※Hysteresis is fixed 2°C during ON/OFF control.

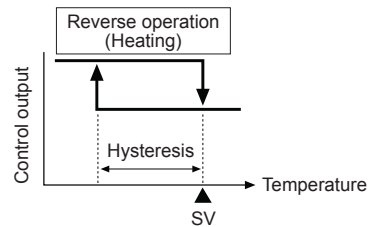

### ● PID control

PID constants are suggested and implemented based on self tuning from supply power until reaching set temperature (SV), then self tuning is over after reaching set temperature (SV).

When power supply, in case that set temperature (SV) dial points at OFF or self tuning can not be started because present temperature (PV) is higher than set temperature (SV) or hunting occurs during self tuning, output control is switched to proportion band (P) because that is considered to error. At that time, proportion band is fixed at 10°C.

※Control cycle of PID control and proportion control is 20 sec in relay output model and 2 sec in SSR drive output model.

### ● STOP

Control output could stop without power off by setting the front setting volume to below min. setting range. If control output stops by STOP function, green indicator in deviation indicator (●) will flash every 1 sec.

### ● Error

Error mark will flash (every 1 sec) in PV indicator when error occurs during the control operation. It will operate normally, if input sensor is connected or returned to normal range.

No	Display	Description
1	▲+●+▼ indicators flash	If input sensor line is broken or sensor is not connected.
2	▲ indicator flashes	If measured sensor input is higher than temperature range.
3	▼ indicator flashes	If measured sensor input is lower than temperature range.

(A) Photoelectric Sensors

(B) Fiber Optic Sensors

(C) Door/Area Sensors

(D) Proximity Sensors

(E) Pressure Sensors

(F) Rotary Encoders

(G) Connectors/ Connector Cables/ Sensor Distribution Boxes/Sockets

(H) Temperature Controllers

(I) SSRs / Power Controllers

(J) Counters

(K) Timers

(L) Panel Meters

(M) Tacho / Speed / Pulse Meters

(N) Display Units

(O) Sensor Controllers

(P) Switching Mode Power Supplies

(Q) Stepper Motors & Drivers & Controllers

(R) Graphic/ Logic Panels

(S) Field Network Devices

(T) Software