

Autonics Motor Driver (5-phase Stepper Motor Driver)

MD5-HF14-AO

INSTRUCTION MANUAL



Thank you for choosing our Autonics product.
Please read the following safety considerations before use.

■ Safety Considerations

- ※Please observe all safety considerations for safe and proper product operation to avoid hazards.
- ※Safety considerations are categorized as follows.
- Warning** Failure to follow these instructions may result in serious injury or death.
- Caution** Failure to follow these instructions may result in personal injury or product damage.
- ※The symbols used on the product and instruction manual represent the following
- ▲ symbol represents caution due to special circumstances in which hazards may occur.

▲ Warning

- Fail-safe device must be installed when using the unit with machinery that may cause serious injury or substantial economic loss.** (e.g. nuclear power control, medical equipment, ships, vehicles, railways, aircraft, combustion apparatus, safety equipment, crime/disaster prevention devices, etc.)
Failure to follow this instruction may result in personal injury, fire, or economic loss.
- Installation, connection, operation, maintenance, and inspection should be handled by qualified individuals.**
Failure to follow this instruction may result in electric shock, or personal injury.
- For installing the unit, ground it exclusively and use over AWG 18 (0.75mm²) ground cables.**
Failure to follow this instruction may result in electric shock.
- Install the unit after considering counter plan against power failure.**
Failure to follow this instruction may result in personal injury or product damage by releasing holding torque of motor.
- Do not use the unit where is outside or flammable or explosive gas, corrosive material, water, vibration, or combustible material may be present.**
Failure to follow this instruction may result in fire, electric shock, or personal injury.
- Do not disassemble or modify the unit. Please contact us if maintenance necessary.**
Failure to follow this instruction may result in electric shock by residual voltage.
- Do not insert any objects at the openings of the unit.**
Failure to follow this instruction may result in fire, electric shock, or personal injury.
- Do not touch the unit or condenser terminals after cut off the power in 30 sec.**
Failure to follow this instruction may result in electric shock by residual voltage.
- Adjust the built-in volume switches by a insulated screw driver.**
Failure to follow this instruction may result in electric shock.
- When connecting connectors, connection part is dangerous voltage. Must insulate**

▲ Caution

- Use the unit within the rated specifications.**
Failure to follow this instruction may result in product damage, degradation, shorten the life cycle of the unit, personal injury, or peripheral devices damage.
- When connecting the power input cables, use the unit within the rated power supply and over AWG18 (0.75mm²) cables.**
Failure to follow this instruction may result in fire, or electric shock.
- Refer to the connection diagrams and check the connection correctly before supplying the power.**
Failure to follow this instruction may result in fire, electric shock, or product damage.
- For connecting the power, install the overcurrent protection devices (current breaker, etc.).**
Failure to follow this instruction may result in fire.
- Turn OFF the power when power is failed.**
Failure to follow this instruction may result in personal injury or product damage due to sudden movement when recover power failure.
- Do not touch the unit during or after operation for a while.**
Failure to follow this instruction may result in burn due to high temperature of the surface.
- Emergency stop should be available during operation.**
Failure to follow this instruction may result in personal injury or product damage.
- Check the control input signal of the unit before supplying the power.**
Failure to follow this instruction may result in personal injury or product damage by unexpected signal input.
- Do not turn on the HOLD OFF signal input while it is maintaining vertical position.**
Failure to follow this instruction may result in personal injury or product damage by releasing holding torque of motor.
- Install safety device when it is required to remain the vertical position after turn off the power.**
Failure to follow this instruction may result in personal injury or product damage by releasing holding torque of motor.
- Check HOLD OFF signal input is ON when moving the output axis (manual positioning etc.) manually.**
Failure to follow this instruction may result in personal injury by unexpected signal input.
- Stop the unit when mechanical problem occurs.**
Failure to follow this instruction may result in fire, or personal injury.
- Do not touch terminals when testing insulation resistance or dielectric strength.**
Failure to follow this instruction may result in electric shock.
- Do not use water or oil-based detergent when cleaning the unit. Use dry cloth to clean the unit.**
Failure to follow this instruction may result in fire, or electric shock.
- Do not move, install, connect, inspect the unit when power is supplied.**
Failure to follow this instruction may result in electric shock.
- When disposing the unit, please categorize it as industrial waste.**
※The above specifications are subject to change and some models may be discontinued without notice.

■ Specifications

Model	MD5-HF14-AO	
Power supply	100-220VAC 50/60Hz	
Allowable voltage fluctuation range	90 to 110% of the rated voltage	
Max. current consumption ^{※1}	3A	
RUN current ^{※2}	0.4-1.4A/Phase	
STOP current	27 to 90% of RUN current (set by STOP current switch)	
Drive method	Bipolar constant current pentagon drive	
Basic step angle	0.72°/step	
Resolution	1, 2, 4, 5, 8, 10, 16, 20, 25, 40, 50, 80, 100, 125, 200, 250-division (0.72° to 0.00288°/step)	
Input pulse characteristic	Pulse width	Min. 1μs (CW, CCW), Min. 1ms (HOLD OFF)
	Duty Rate	50% (CW, CCW)
	Rising/Falling time	Below 130ns (CW, CCW)
	Pulse input voltage	[H]: 4-8VDC, [L]: 0-0.5VDC
	Pulse input current	7.5-14mA (CW, CCW), 10-16mA (HOLD OFF)
Max. input pulse frequency ^{※3}	Max. 500kHz (CW, CCW)	
Input resistance	270Ω (CW, CCW), 390Ω (HOLD OFF), 10Ω (ALARM)	
Insulation resistance	Over 100MΩ (at 500VDC megger, between all terminals and case)	
Dielectric strength	1,000VAC 50/60Hz for 1min. (between all terminals and case)	
Noise resistance	±2000V the square wave noise (pulse width: 1μs) by the noise simulator	
Vibration	Mechanical	1.5mm amplitude at frequency of 5 to 60Hz (for 1 min) in each X, Y, Z direction for 2 hours
	Malfunction	1.5mm amplitude at frequency of 5 to 60Hz (for 1 min) in each X, Y, Z direction for 10 min.
Environment	Ambient temp.	0 to 50°C, storage: -10 to 60°C
	Ambient humi.	35 to 85%RH, storage: 35 to 85%RH
Approval	CE	
Weight ^{※4}	Approx. 820g (approx. 660g)	

- ※1: Based on ambient temperature 25°C, ambient humidity 55%RH.
- ※2: RUN current varies depending on the input RUN frequency and max. RUN current at the moment varies also varies depending on the load.
- ※3: Max. input pulse frequency is max. frequency to be input and is not same as max. pull-out frequency or max. slewing frequency.
- ※4: The weight includes packaging. The weight in parenthesis is for unit only.
- ※Environment resistance is rated at no freezing or condensation.

■ Dimensions

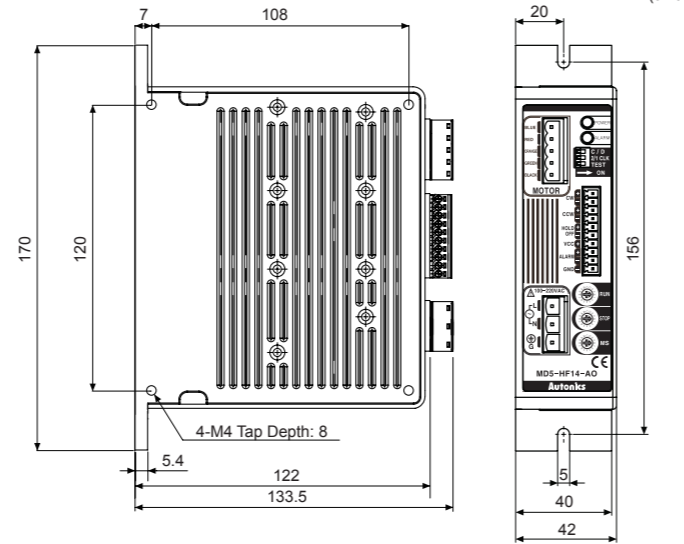

■ Time Chart

○ 1-pulse input method

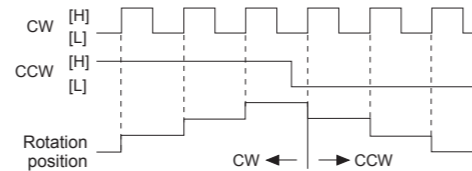

○ 2-pulse input method

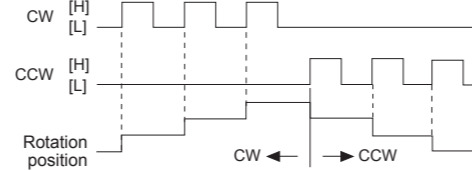

※Do not input CW, CCW signals at the same time in 2-pulse input method.
It may not operate properly if another direction signal is inputted when one of CW or CCW is [H].

○ HOLD OFF function

- This signal is for rotating motor's axis using external force or used for manual positioning.
- When hold off signal maintains over 1ms as [H], motor excitation is released.
- When hold off signal maintains over 1ms as [L], motor excitation is in a normal status.
- Must stop the motor for using this function.
- Refer to I/O Circuit And Connections.

■ I/O Circuit And Connections

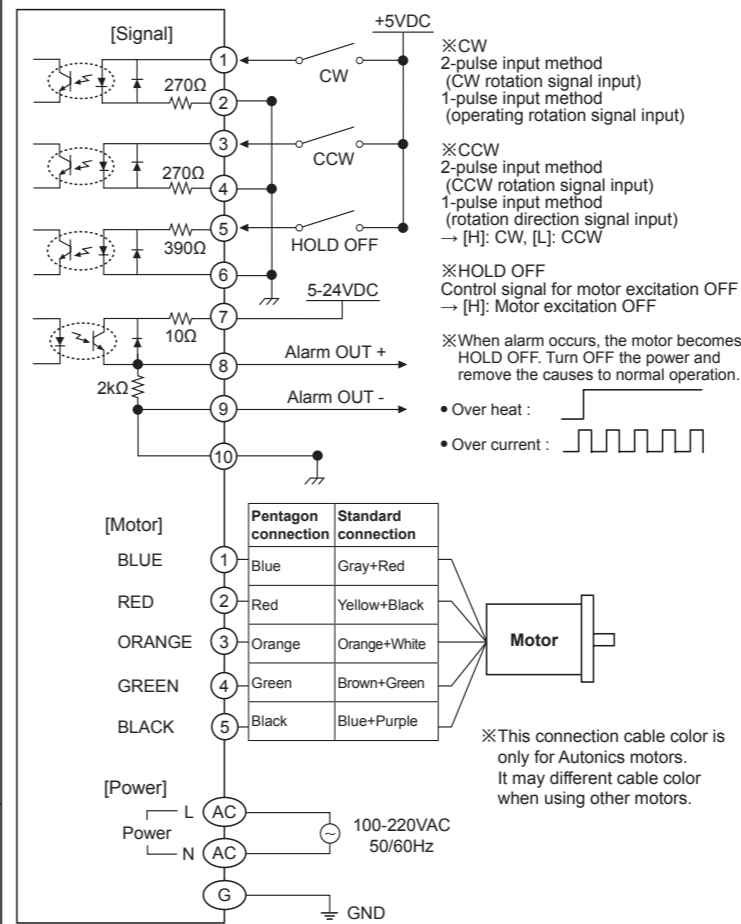

■ Functions

○ Function selection DIP switch

No.	Name	Function	Switch position	
			ON	OFF (default)
1	TEST	Self diagnosis function	30rpm rotation	Not use
2	2/1 CLK	Pulse input method	1-pulse input method	2-pulse input method
3	C/D	Auto current down	Not use	Use

- TEST**
- Self diagnosis function is for motor and driver test.
- This function makes the motor rotate with 30rpm in full step. Rotation speed varies with resolution settings.
- Rotation speed = 30rpm/resolution
- In 1-pulse input method, it rotates to CCW, and in 2-pulse input method, it rotates to CW.
- Be sure that the TEST switch is OFF before supplying the power.
- If the TEST switch is ON, the motor operates immediately and it may be dangerous.
- 2/1 CLK**
- 1/2 CLK switch is to select pulse input method.
- 1-pulse input method: CW → operating rotation signal input, CCW → rotation direction signal input ([H]: CW, [L]: CCW)
- 2-pulse input method: CW → CW rotation signal input, CCW → CCW rotation signal input.
- C/D (auto current down)**
- This function is to reduce the current provided for motor automatically for preventing severe motor's heat when motor stops.
- If motor RUN pulse is not applied, the current provided for motor reduces as the set STOP current.
- Be sure that when motor RUN current is reduced, the stop torque of motor also reduced.
- Set the STOP current by the STOP current setting switch.

○ Setting RUN current

Switch No	0	1	2	3	4	5	6	7	8	9	A	B	C	D	E	F
Current (A/Phase)	0.4	0.5	0.57	0.63	0.71	0.77	0.84	0.9	0.96	1.02	1.09	1.15	1.22	1.27	1.33	1.4

- RUN current setting is for the current provided for motor when the motor runs.
- When RUN current is increased, RUN torque of the motor is also increased.
- When RUN current is set too high, the heat is severe.
- Set RUN current within the range of motor's rated current according to its load.
- Change RUN current only when the motor stops.

○ Setting STOP current

Switch No	0	1	2	3	4	5	6	7	8	9	A	B	C	D	E	F
%	27	31	36	40	45	50	54	58	62	66	70	74	78	82	86	90

- STOP current setting is for the current provided for motor when the motor stops for preventing severe motor's heat.
- This setting is applied when using C/D (Current/down) function.
- Setting value of STOP current is percentage (%) ratio of the set RUN current.
E.g.) Set RUN current as 1.4A and STOP current as 40%.
STOP current is set as 1.4A×0.4=0.56A.
- When STOP current is decreased, STOP torque of the motor is also decreased.
- When STOP current is set too low, the heat is lower.
- Change STOP current only when the motor stops.

○ Setting microstep (microstep: resolution)

Switch No	0	1	2	3	4	5	6	7	8	9	A	B	C	D	E	F
Resolution	1	2	4	5	8	10	16	20	25	40	50	80	100	125	200	250
Step angle	0.72°	0.36°	0.18°	0.144°	0.09°	0.072°	0.045°	0.036°	0.0288°	0.018°	0.0144°	0.009°	0.0072°	0.00576°	0.0036°	0.00288°

● Setting resolution (MS1)

- The set step angle is dividing basic step angle (0.72°) of 5-phase stepping motor by setting value.
- The calculation formula of divided step angle is as below.
Set step angle = Basic step angle (0.72°) / Resolution

- When using geared type motor, the angle is step angle divided by gear ratio.
Step angle / gear ratio = Step angle applied gear
E.g) 0.72° / 10 (1:10) = 0.072°
- Must stop the motor before changing the resolution.

○ Alarm output function

- Overheat:** When the temperature of driver base is over 80°C, alarm LED (Red) turns ON and motor stops with holding the excision. Turn OFF the power and remove the causes. Turn ON the power and alarm output is OFF.
- Overcurrent:** When overcurrent is applied from motor damage by burn, driver damage, or error, alarm LED (Red) is flashed. When overcurrent occurs, the motor becomes HOLD OFF. Turn OFF the power and remove the causes to normal operation.

■ Cautions During Use

1. For signal input

- Do not input CW, CCW signal at the same time in 2-pulse input method. Failure to follow this instruction may result in malfunction. It may not operate properly if another direction signal is inputted when one of CW or CCW is [H].
- When the signal input voltage is exceeded the rated voltage, connect additional resistance at the outside.

2. For RUN current, STOP current setting

- Set RUN current within the range of motor's rated current. Failure to follow this instruction may result in severe heat of motor or motor damage.
- If motor stops, switching for STOP current executed by the current down function. When hold off signal is [H] or current down function is OFF, the switching does not execute.
- Use the power for supplying sufficient current to the motor.

3. For cable connection

- Use twisted pair (over 0.2mm²) for the signal cable which should be shorter than 2m.
- The thickness of cable should be same or thicker than the motor cable's when extending the motor cable.
- Must separate between the signal cable and the power cable over 10cm.

4. For installation

- In order to increase heat protection efficiency of the driver, must install the heat sink close to metal panel and keep it well-ventilated.
- Excessive heat generation may occur on driver. Keep the heat sink under 80°C when installing the unit. (at over 80°C, forcible cooling shall be required.)

5. For using function selection DIP switches

- Be sure that the TEST switch is OFF before supplying the power. If the TEST switch is ON, the motor operates immediately and it may be dangerous.
- Do not change the pulse input method during the operation. It may cause danger as the revolution way of the motor is changed conversely.

6. This product may be used in the following environments.

- Indoor
- Altitude under 2000m
- Pollution degree 2
- Installation category II

※Failure to follow these instructions may result in product malfunction.

■ Major products

- Photoelectric Sensors
- Fiber Optic Sensors
- Door Sensors
- Door Side Sensors
- Area Sensors
- Proximity Sensors
- Pressure Sensors
- Rotary Encoders
- Connectors/Sockets
- Switching Mode Power Supplies
- Control Switches/Lamps/Buzzers
- I/O Terminal Blocks & Cables
- Stepper Motors/Drivers/Motion Controllers
- Graphic/Logic Panels
- Field Network Devices
- Laser Marking System (Fiber, CO₂, Nd: YAG)
- Laser Welding/Cutting System
- Temperature Controllers
- Temperature/Humidity Transducers
- SSRs/Power Controllers
- Counters
- Timers
- Panel Meters
- Tachometer/Pulse (Rate) Meters
- Display Units
- Sensor Controllers

Autonics Corporation
http://www.autonics.com

HEAD QUARTERS:
18, Bansong-ro 513 beon-gil, Haeundae-gu, Busan, South Korea, 48002

OVERSEAS SALES:
#402-303, Buecheon Techno Park, 655, Pyeongcheon-ro, Wonmi-gu, Buecheon, Gyeonggi-do, South Korea, 14502
TEL: 82-32-610-2730 / FAX: 82-32-329-0728
E-mail: sales@autonics.com