

## Performance

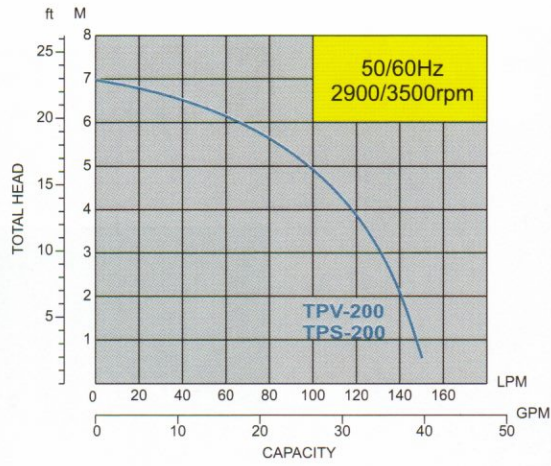

## TPV



## TPS



## Construction

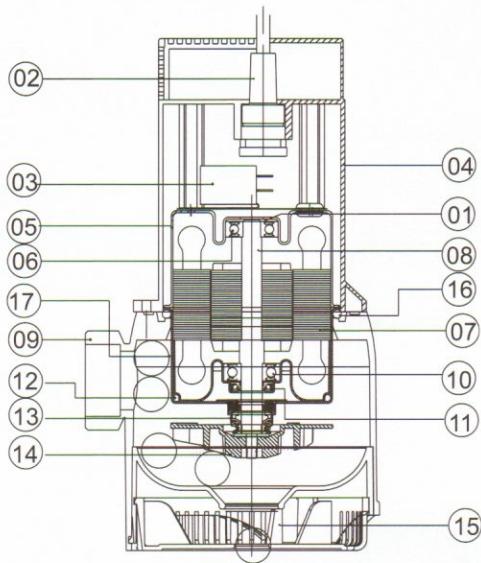

No.	Description	Material
1	Wave Spring	STEEL
2	Cord	H05RNF
3	Capacitor	PP
4	Motor Housing	PP+GF
5	Upper Bearing Cover	SUS304
6	Bearing	CMN5K
7	Stator Laminated	S. STEEL
8	Shaft	SUS410
9	Pump & Discharge	PP+GF
10	Lower Bearing	CMN5K
11	Oil Seal (TPV-200)	CA/CE
12	O-ring	NBR
13	Mechanical Seal(TPS-200)	CA/CE
13	Mechanical Seal(TPS-200S)	SIL/CE
13	Mechanical Seal(TPV-200)	CA/CE
13	Mechanical Seal(TPV-200S)	SIL/CE
14	Impeller	PP+GF
15	Strainer	PP+GF
16	O-ring	EPDM
17	Lower Bearing Cover	SUS304

Remarks: TPV-200S & TPS-200S are for light acid, alkali and sea water use.  
Model with "A" is equipped with float switch.

## Specification

TYPE	OUTPUT		OUTLET		RATED		MAXIMUM		Dimension (m/m)			Weight
					head	capacity	head	capacity				
	HP	W	mm	inch	M	LPM	M	LPM	L	W	H	Kg
TPV-200 TPS-200	1/4	200	32	1-1/4"	4	120	7	140	168	146	288	3.6