



This is module which inputs 8ch of DC signal.
It is compatible with Modbus (RTU) of general purpose protocol.

Features

- ★ 8ch input of DC voltage / current
- ★ RS-485 Modbus (RTU) compatible
- ★ Zero span adjustment and low cut setting by RS-485
- ★ Baud rate and Node address setting by front switch
- ★ Easy maintenance by removable terminal block from body

Ordering code

WMB - AI8 - D 00

Series	Type	Input	Power supply	Test report	Suffix	Description
WMB	AI8					Series Modbus I/O module
		11				Type Analog input 8ch
		12				0~100mVDC (Input resistance 1MΩ)
		13				0~1VDC (Input resistance 1MΩ)
		14				0~5VDC (Input resistance 1MΩ)
		15				1~5VDC (Input resistance 1MΩ)
		23				0~10VDC (Input resistance 1MΩ)
		24				±1VDC (Input resistance 1MΩ)
		25				±5VDC (Input resistance 1MΩ)
		35				±10VDC (Input resistance 1MΩ)
		36				0~20mADC (Input resistance 50Ω)
		56				4~20mADC (Input resistance 50Ω)
			D			Power supply 24VDC ±10%
				0		Test report Without test report
				1		Test report With test report
					00	Suffix Standard

Specifications

Input Specifications

Input signal	DC voltage / current
Number of inputs	8
Input Configuration	Single ended
A/D conversion	ΔΣ conversion
Sampling rate	Apporx. 150ms/1ch
Allowable input	±0.1% Full scale
Influence of ambient temperature	±0.01% Full scale per °C
Input common	1 common for each input
Setting	Span/zero adjustment, Simulated input, Low cut (Setting by RS-485)

Standard Specifications

Power supply	24VDC ±10%
Power consumption	Less than 50mA max.
Operating temperature/humidity	-5 to 55°C, 90% (non-condensing)
Storage temperature/humidity	-20 to 60°C, 90% (non-condensing)
Warm-up time	30 min
Dielectric strength	1500VAC per 1 min. : Between Power -
Insulation resistance	500Vdc, 100MΩ or more
Dimensions	65(W) x 110(H) x 48mm(D) DIN size
Weight	Approx. 220g
Connection	M3 screw terminal block (removable), 14P, 10P (Tightening torque 0.5N·m)
Mounting	DIN rail or wall surface

RS-485 Specifications

Standard	Conform to RS-485
Baud rate	4800 / 9600 / 19200 / 38400 bps (Selectable by DIP switch)
Terminal resistance	Approx. 120Ω (Standard accessory)
Max. No. of connection	31
Node address	1 to 99 (Setting by Rotary switch)
Transmission distance	Approx. 500m or less (Depends on connection device and)
Communication form	1:N communication
Protocol	Modbus (RTU) protocol

Dimensions

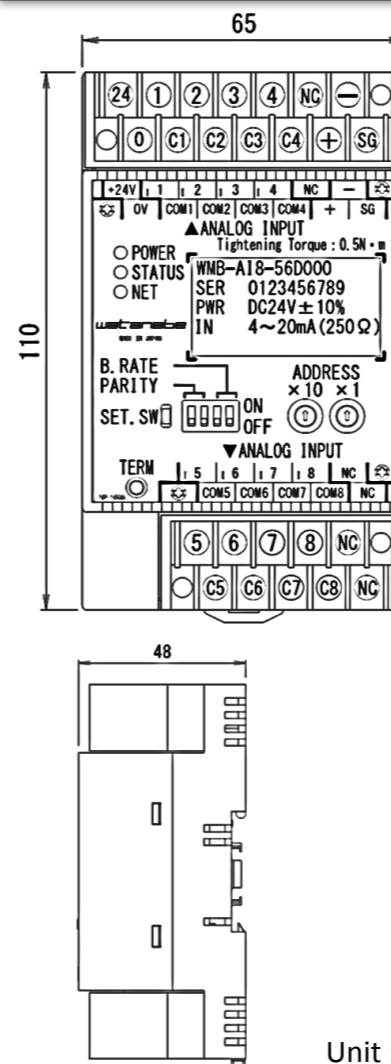

No	Symbol	Description
24	Power supply	+24V Power supply
0		0V
1	Analog input	I1 Analog input 1
C1		COM1 Common 1
2		I2 Analog input 2
C2		COM2 Common 2
3		I3 Analog input 3
C3		COM3 Common 3
4		I4 Analog input 4
C4		COM4 Common 4
	NC	No connection
+	RS485	+ RS-485 + terminal
-		- RS-485 - terminal
SG		SG RS-485 SG terminal
5	Analog input	I5 Analog input 5
C5		COM5 Common 5
6		I6 Analog input 6
C6		COM6 Common 6
7		I7 Analog input 7
C7		COM7 Common 7
8		I8 Analog input 8
C8		COM8 Common 8
	NC	No connection
	NC	No connection

Unit : mm

Block Diagram

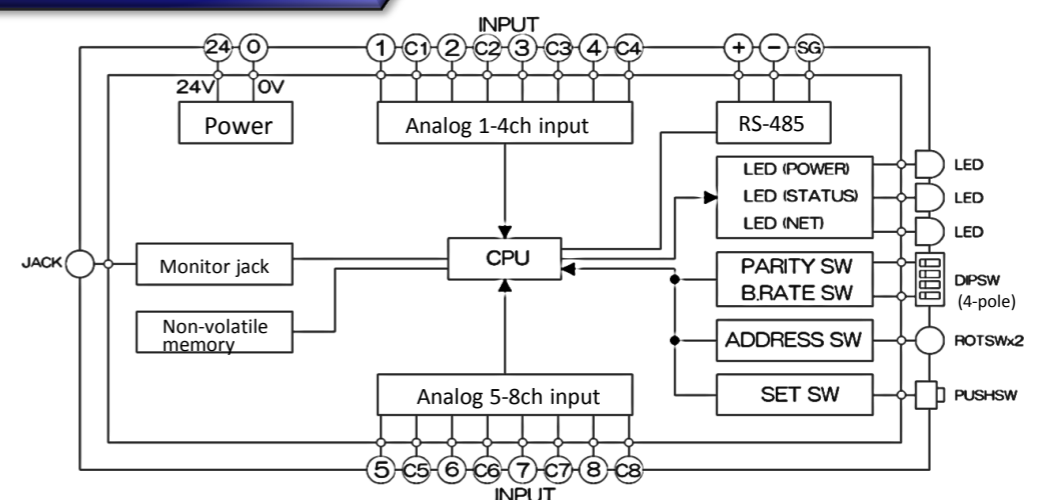

* Specification is subject to change without notice