

Modbus I/O Module

WMB Series

NEW

Multiple Analog input signals to RS-485 (Modbus RTU) communication!



1. Multi Ch input

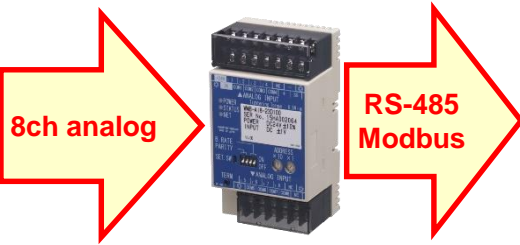

WMB-AI8

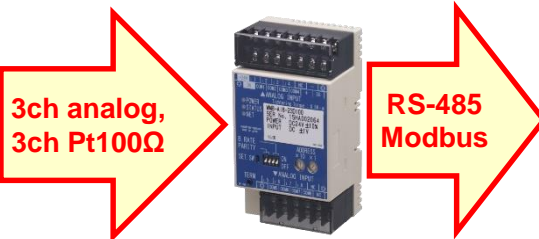

WMB-MAI8

2. Compact Size



3. Easy wiring

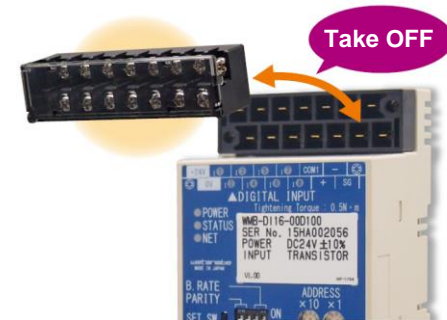

WMB Series Line-up

- Analog input module
WMB-AI8 (Analog input 8ch)
- Analog / RTD input module
WMB-MAI6 (Analog input 3ch, Pt100Ω input 3ch)

WMB Application ①

1) Current system (converter)

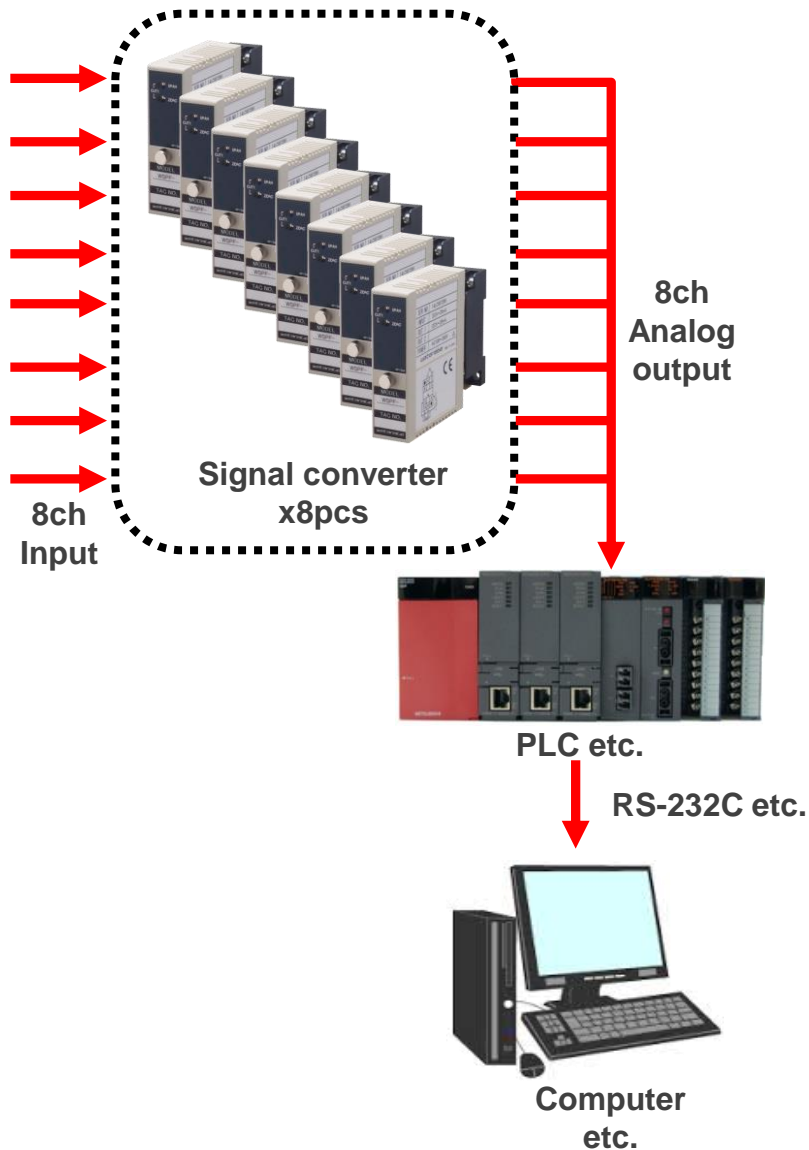

2) In case WMB-AI8

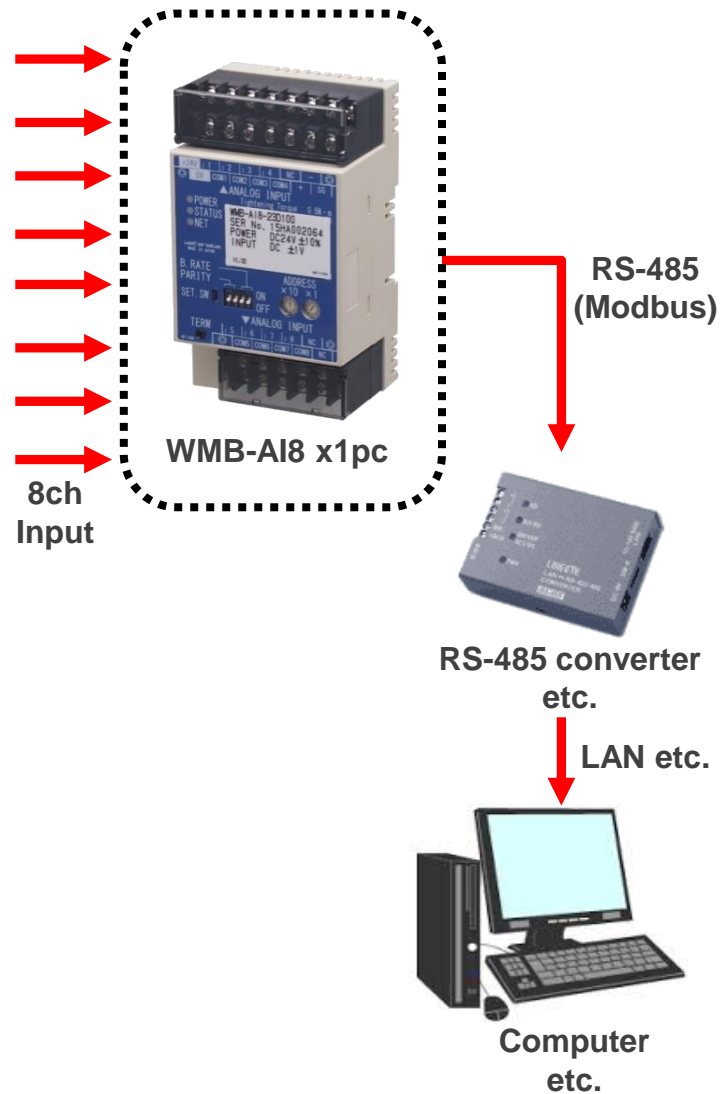

WMB Application ②

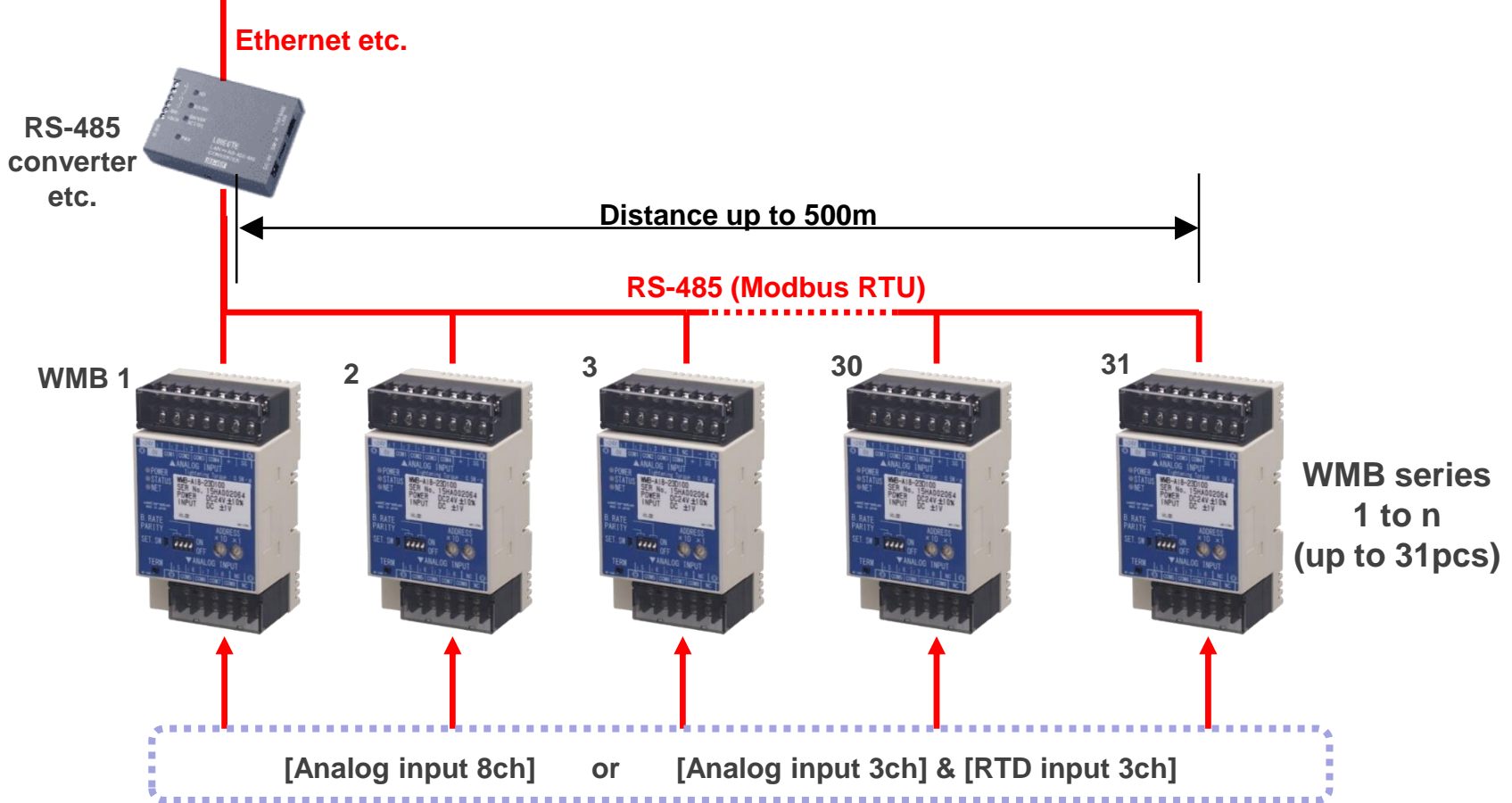

WMB Application ③

